

EN

ORIGINAL INSTRUCTIONS  
CORDLESS ANGLE GRINDER



**Table of contents**

**Information on the use of these instructions** ..... 2

**Safety** ..... 3

**Information about the device** ..... 9

**Transport and storage** ..... 11

**Start-up** ..... 12

**Operation** ..... 17

**Available accessories** ..... 18

**Errors and faults** ..... 19

**Maintenance** ..... 20

**Disposal** ..... 20

**EU Declaration of Conformity (original)** ..... 21

**Information on the use of these instructions**

**Symbols**

 **Warning of electrical voltage**  
This symbol indicates dangers to the life and health of persons due to electrical voltage.

 **Warning of explosive substances**  
This symbol indicates dangers to the life and health of persons due to potentially explosive substances.

 **Warning of hot surface**  
This symbol indicates dangers to the life and health of persons due to hot surface.

 **Warning**  
This signal word indicates a hazard with an average risk level which, if not avoided, can result in serious injury or death.

 **Caution**  
This signal word indicates a hazard with a low risk level which, if not avoided, can result in minor or moderate injury.

**Notice**  
This signal word indicates important information (e.g. material damage), but does not indicate hazards.

 **Info**  
Information marked with this symbol helps you to carry out your tasks quickly and safely.

 **Follow the manual**  
Information marked with this symbol indicates that the instructions must be observed.

 **Wear head protection**  
Wear appropriate head protection when working with the device.

 **Wear hearing protection**  
Information marked with this symbol indicates that you should wear hearing protection.

 **Wear safety glasses**  
Information marked with this symbol indicates that you should wear eye protection.

 **Wear a protective mask**  
Information marked with this symbol indicates that you should wear a protective mask.

 **Wear protective clothing**  
Information marked with this symbol indicates that you should wear protective clothing.

 **Wear protective gloves**  
Information marked with this symbol indicates that you should wear protective gloves.

 **Wear foot protection**  
Information marked with this symbol indicates that you should wear safety boots.

 **Use both hands to hold onto the power tool.**  
This symbol indicates that the power tool should always be held with both hands on the handle and additional handle.

 **Do not use damaged discs**  
This symbol indicates that the device must not be operated with faulty accessories.

 **Accessory suited for metallic materials**  
This symbol indicates that the supplied accessory is **only** to be used for metal.

 **Not permissible for wet grinding**  
Information marked with this symbol indicates that wet grinding is prohibited.

 **Accessory not suitable for roughing operations**  
This symbol indicates that the supplied accessory must **not** to be used for roughing.

 **Accessory suited for cutting operations**  
This symbol indicates that the supplied accessory may be used for cutting.

You can download the current version of these instructions via the following link:



PAGS 21-115 NB



<https://hub.trotec.com/?id=41427>

## Safety

### General Power Tool Safety Warnings



#### Warning

**Read all safety warnings, instructions, illustrations and specifications provided with this power tool.**

Failure to follow all instructions listed below may result in electric shock, fire and/or serious injury.

**Save all warnings and instructions for future reference.**

The term *power tool* in the warnings refers to your mains-operated (corded) power tool or battery-operated (cordless) power tool.



#### General Power Tool Safety Warnings – Work area safety

- **Keep work area clean and well lit.** Clutter or dark areas invite accidents.
- **Do not operate power tools in explosive atmosphere, such as in the presence of flammable liquids, gases or dust.** Power tools create sparks which may ignite the dust or fumes.
- **Keep children and bystanders away while operating a power tool.** Distractions can cause you to lose control.



#### General Power Tool Safety Warnings – Electrical safety

- **Power tool plugs must match the outlet. Never modify the plug in any way. Do not use any adapter plugs with earthed (grounded) power tools.** Unmodified plugs and matching outlets will reduce risk of electric shock.
- **Avoid body contact with earthed or grounded surfaces, such as pipes, radiators, ranges and refrigerators.** There is an increased risk of electric shock if your body is earthed or grounded.
- **Do not expose power tools to rain or wet conditions.** Water entering a power tool will increase the risk of electric shock.

- **Do not abuse the cord. Never use the cord for carrying, pulling or unplugging the power tool. Keep cord away from heat, oil, sharp edges or moving parts.** Damaged or entangled cords increase the risk of electric shock.
- **When operating a power tool outdoors, use an extension cord suitable for outdoor use.** Use of a cord suitable for outdoor use reduces the risk of electric shock.
- **If operating a power tool in a damp location is unavoidable, use a residual current device (RCD) protected supply.** Use of an RCD reduces the risk of electric shock.



#### General Power Tool Safety Warnings – Personal safety

- **Stay alert, watch what you are doing and use common sense when operating a power tool. Do not use a power tool while you are tired or under the influence of drugs, alcohol or medication.** A moment of inattention while operating power tools may result in serious personal injury.
- **Use personal protective equipment. Always wear eye protection.** Protective equipment such as a dust mask, non-skid safety shoes, hard hat or hearing protection used for appropriate conditions will reduce personal injuries.
- **Prevent unintentional starting. Ensure the switch is in the off-position before connecting to power source and/or battery pack, picking up or carrying the tool.** Carrying power tools with your finger on the switch or energising power tools that have the switch on invites accidents.
- **Remove any adjusting key or wrench before turning the power tool on.** A wrench or a key left attached to a rotating part of the power tool may result in personal injury.
- **Do not overreach. Keep proper footing and balance at all times.** This enables better control of the power tool in unexpected situations.
- **Dress properly. Do not wear loose clothing or jewellery. Keep your hair and clothing away from moving parts.** Loose clothes, jewellery or long hair can be caught in moving parts.
- **If devices are provided for the connection of dust extraction and collection facilities, ensure these are connected and properly used.** Use of dust collection can reduce dust-related hazards.
- **Do not let familiarity gained from frequent use of tools allow you to become complacent and ignore tool safety principles.** A careless action can cause severe injury within a fraction of a second.



### General Power Tool Safety Warnings – Power tool use and care

- **Do not force the power tool. Use the correct power tool for your application.** The correct power tool will do the job better and safer at the rate for which it was designed.
- **Do not use the power tool if the switch does not turn it on and off.** Any power tool that cannot be controlled with the switch is dangerous and must be repaired.
- **Disconnect the plug from the power source and/or remove the battery pack, if detachable, from the power tool before making any adjustments, changing accessories, or storing power tools.** Such preventive safety measures reduce the risk of starting the power tool accidentally.
- **Store idle power tools out of the reach of children and do not allow persons unfamiliar with the power tool or these instructions to operate the power tool.** Power tools are dangerous in the hands of untrained users.
- **Maintain power tools and accessories. Check for misalignment or binding of moving parts, breakage of parts and any other condition that may affect the power tool's operation. If damaged, have the power tool repaired before use.** Many accidents are caused by poorly maintained power tools.
- **Keep cutting tools sharp and clean.** Properly maintained cutting tools with sharp cutting edges are less likely to bind and are easier to control.
- **Use the power tool, accessories and tool bits etc. in accordance with these instructions, Take into account the working conditions and the work to be performed.** Use of the power tool for operations different from those intended could result in a hazardous situation.
- **Keep handles and grasping surfaces dry, clean and free from oil and grease.** Slippery handles and grasping surfaces do not allow for safe handling and control of the tool in unexpected situations.



### General Power Tool Safety Warnings – Battery tool use and care

- **Recharge only with charger specified by the manufacturer.** A charger that is suitable for one type of battery pack may create a risk of fire when used with another battery pack.
- **Use power tools only with specifically designed battery packs.** Use of any other battery packs may create a risk of injury and fire.

- **When battery pack is not in use, keep it away from other metal objects, like paper clips, coins, keys, nails, screws or other small metal objects, that can make a connection from one terminal to another.** Shorting the battery terminals together may cause burns or a fire.
- **Under abusive conditions, liquid may be ejected from the battery; avoid contact. If contact accidentally occurs, flush with water. If liquid contacts eyes, additionally seek medical help.** Liquid ejected from the battery may cause irritation or burns.
- **Do not use a battery pack or tool that is damaged or modified.** Damaged or modified batteries may exhibit unpredictable behaviour resulting in fire, explosion or risk of injury.
- **Do not expose a battery pack or tool to fire or excessive temperature.** Exposure to fire or temperature above 130 °C may cause explosion.
- **Follow all charging instructions and do not charge the battery pack or tool outside the temperature range specified in the instructions.** Charging improperly or at temperatures outside the specified range may damage the battery and increase the risk of fire.



### General Power Tool Safety Warnings – Service

- **Have your power tool serviced by a qualified repair person using only identical replacement parts.** This will ensure that the safety of the power tool is maintained.
- **Never service damaged battery pack.** Service of battery packs should only be performed by the manufacturer or authorized service providers.



### General Power Tool Safety Warnings – Charger use and care

- **This charger can be used by children aged from 8 years and above and persons with reduced physical, sensory or mental capabilities or lack of experience and knowledge if they have been given supervision or instruction concerning use of the appliance in a safe way and understand the hazards involved. Children shall not play with the appliance.** Cleaning and user maintenance shall not be made by children without supervision.
- **Never insert non-rechargeable batteries into the charger.** A charger that is suitable for one type of battery pack may create a risk of fire and explosion, when used with another battery pack or non-rechargeable batteries.
- **Only charge the Li-Ion battery "Multiflex 20 – 4.0 DC" (capacity of 4.0 Ah = 10 battery cells) with the charger "Multiflex 20 – 4.0 AC".** The battery voltage must match the battery charging voltage of the charger.



### Safety Warnings Common for Abrasive Cutting-Off Operations

- **This power tool is intended to function as a cut-off tool. Read all safety warnings, instructions, illustrations and specifications provided with this power tool.** Failure to follow all instructions listed below may result in electric shock, fire and/or serious injury.
- **This power tool is not suitable for grinding, sandpaper grinding, wire brushing, polishing and cutting holes.** Operations for which the power tool was not designed may create a hazard and cause personal injury.
- **Do not use the power tool for a function for which it is not expressly designed and intended by its manufacturer.** Such a conversion can cause a loss of control and serious bodily injury.
- **Do not use accessories which are not specifically designed and recommended by the tool manufacturer.** Just because the accessory can be attached to your power tool, it does not assure safe operation.
- **The rated speed of the accessory must be at least equal to the maximum speed marked on the power tool.** Accessories running faster than their rated speed can break and fly apart.
- **The outside diameter and the thickness of your accessory must be within the capacity rating of your power tool.** Incorrectly sized accessories cannot be adequately guarded or controlled.
- **Threaded mounting of accessories must match the grinder spindle thread. For accessories mounted by flanges, the arbour hole of the accessory must fit the locating diameter of the flange.** Accessories that do not precisely match the mounting hardware of the power tool will run out of balance, vibrate excessively and may cause loss of control.
- **Wear personal protective equipment. Depending on application, use face shield, safety goggles or safety glasses. As appropriate, wear dust mask, hearing protectors, gloves and workshop apron capable of stopping small abrasive or workpiece fragments.** The eye protection must be capable of stopping flying debris generated by various operations. The dust mask or respirator must be capable of filtering particles generated by your operation. Prolonged exposure to high intensity noise may cause hearing loss.
- **Keep bystanders a safe distance away from work area. Anyone entering the work area must wear personal protective equipment.** Fragments of workpiece or of a broken accessory may fly away and cause injury beyond immediate area of operation.

- **Only hold the power tool by its insulated gripping surfaces when performing an operation where the accessory may contact hidden wiring.** Cutting accessory contacting a "live" wire may make exposed metal parts of the power tool "live" and could give the operator an electric shock.
- **Never lay the power tool down until the accessory has come to a complete stop.** The spinning accessory may grab the surface and pull the power tool out of your control.
- **Do not run the power tool while carrying it at your side.** Accidental contact with the spinning accessory could snag your clothing, pulling the accessory into your body.
- **Regularly clean the power tool's air vents.** The motor's fan will draw the dust inside the housing and excessive accumulation of powdered metal may cause electrical hazards.
- **Do not operate the power tool near flammable materials.** Sparks could ignite these materials.
- **Do not use accessories that require liquid coolants.** Using water or other liquid coolants may result in electrocution or shock.



### Kickback and Related Warnings

Kickback is a sudden reaction to a pinched or snagged rotating wheel, backing pad, brush or any other accessory. Pinching or jamming causes rapid stalling of the rotating accessory. This will accelerate an uncontrolled power tool towards the direction opposite of the accessory's rotation at the point of the jamming. For example, if an abrasive wheel is snagged or pinched by the workpiece, the edge of the wheel that is entering into the pinch point can dig into the surface of the material causing the wheel to climb out or kick out. The wheel may either jump toward or away from the operator, depending on direction of the wheel's movement at the point of pinching. Abrasive wheels may also break under these conditions.

Kickback is the result of power tool misuse and/or incorrect operating procedures or conditions. Kickback can be avoided by taking proper precautions as given below.

- **Maintain a firm grip on the power tool and position your body and arm to allow you to resist kickback forces. Always use auxiliary handle, if provided, for maximum control over kickback or torque reaction during start-up.** The operator can control torque reactions or kickback forces, if proper precautions are taken.
- **Never place your hand near the rotating accessory.** Accessory may kickback over your hand.

- **Do not position your body in the area where power tool will move if kickback occurs.** Kickback will propel the tool in direction opposite to the wheel's movement at the point of snagging.
- **Use special care when working corners, sharp edges etc. Prevent the accessories from bouncing against the workpiece and getting caught.** Corners, sharp edges or bouncing have a tendency to snag the rotating accessory. The result would be a loss of control or kickback.
- **Do not use a chainsaw blade for cutting wood nor a segmented diamond cutting disc with a segment spacing exceeding 10 mm nor toothed saw blades.** Such blades create frequent kickback and loss of control.



**Additional Safety Warnings Specific for Abrasive Cutting-Off Operations**

- **Do not "jam" the cut-off wheel or apply excessive pressure. Do not attempt to make an excessive depth of cut.** Overstressing the wheel increases the loading and susceptibility to twisting or binding of the wheel in the cut and the possibility of kickback or wheel breakage.
- **Do not position your body in line with and behind the rotating wheel.** When the wheel, at the point of operation, is moving away from your body, the possible kickback may propel the spinning wheel and the power tool directly at you.
- **When wheel is binding or when interrupting a cut for any reason, switch off the power tool and hold the power tool motionless until the wheel comes to a complete stop. Never attempt to remove the cut-off wheel from the cut while the wheel is in motion otherwise kickback may occur.** Investigate and take corrective action to eliminate the cause of wheel binding.
- **Do not restart the cutting operation in the workpiece. Let the wheel reach full speed and carefully re-enter the cut.** The wheel may bind, walk up or kickback if the power tool is restarted in the workpiece.
- **Support panels or any oversized workpiece to minimize the risk of wheel pinching and kickback. Large workpieces tend to sag under their own weight.** Supports must be placed under the workpiece near the line of cut and near the edge of the workpiece on both sides of the wheel.
- **Use extra caution when making a "pocket cut" into existing walls or other blind areas.** The protruding wheel may cut gas or water pipes, electrical wiring or objects that can cause kickback.
- **Do not attempt to make any curved cuts.** Overstressing the wheel increases the loading and susceptibility to twisting or binding of the wheel in the cut and the possibility of kickback or wheel breakage which can lead to serious injuries.



**Safety Warnings Specific for Abrasive Cutting-Off Operations**

- **Use only wheel types that are recommended for your power tool and the specific guard designed for the selected wheel.** Wheels for which the power tool was not designed cannot be adequately guarded and are unsafe.
- **The grinding surface of centre depressed wheels must be mounted below the plane of the guard lip.** An improperly mounted wheel that projects through the plane of the guard lip cannot be adequately protected.
- **The guard must be securely attached to the power tool and positioned for maximum safety, so the least amount of wheel is exposed towards the operator.** The guard helps to protect operator from broken wheel fragments and accidental contact with wheel.
- **Wheels must be used only for recommended applications. For example: do not grind with the side of cut-off wheel.** Cutting discs are designed for material removal using the edge of the disc. Exerting force to the sides of these abrasives may break them.
- **Always use undamaged wheel flanges that are of correct size and shape for your selected wheel.** Proper wheel flanges support the wheel thus reducing the possibility of wheel breakage. Flanges for cut-off wheels may be different from grinding wheel flanges.
- **Do not use worn down wheels from larger power tools.** Wheel intended for larger power tool is not suitable for the higher speed of a smaller tool and may burst.
- **When using discs for several purposes, always use the appropriate protective cover for the application being performed.** Failure to use the correct protective cover may result in improper shielding and cause severe injury.

**Intended use**

Only use the device PAGS 21-115 NB for:

- for cutting metal as well as stone materials without the use of water
- for cutting tiles and concrete blocks. When cutting stone, an adequate dust extraction system must be provided.

We recommend using the power tool with original accessories from the manufacturer.

Any use other than the intended use is regarded as misuse.

## Reasonably foreseeable misuse

- This power tool is not suitable for operations such as grinding (e.g. sandpaper grinding), polishing and brushing.
- Do not use accessories that require liquid coolants.
- Do not use this power tool for processing wood.
- Do not use this power tool for drilling holes with drill bits.

## Personnel qualification

People who use this device must:

- have read and understood the instructions, especially the Safety chapter.

## Safety signs and labels on the battery and the charger

### Notice

Do not remove any safety signs, stickers or labels from the device. Keep all safety signs, stickers and labels in legible condition.

The following safety signs and labels are attached to the battery:



### Warning of explosion risk!

These symbols indicate the following:



Do not expose the battery pack or tool to fire or excessive temperature! Do not let the battery come into contact with water or fire! Avoid direct sunlight and moisture. There is a risk of explosion!

Never charge the battery at ambient temperatures below 10 °C or above 40 °C. Charging improperly or at temperatures outside the specified range may damage the battery and increase the risk of fire.



### Observe the correct disposal of the battery!

This symbol indicates the following:

Ensure that the battery is disposed of correctly and never dispose of it in waste water or public waters. The battery contains irritating, caustic and toxic substances that pose significant risks to people and the environment.

The following safety signs and labels are attached to the charger:



This symbol indicates the following:

Read the instructions or operating manual before charging the battery.



This symbol indicates the following:

Only use the charger for charging the battery in dry interior spaces. Do not charge the device outdoors.

## Personal protective equipment



### Wear protective headgear.

With it you protect your head from splintering, falling and flying pieces which could cause injuries.



### Wear hearing protection.

Excessive noise can lead to hearing loss.



### Wear eye protection.

With it you protect your eyes from splintering, falling and flying pieces which could cause injuries.



### Wear a protective mask.

It saves you from inhaling harmful dusts generated when processing workpieces.



### Wear protective gloves.

They protect your hands from burns, crushing injuries and skin abrasions.



### Wear tight-fitting protective clothing.

















This protects you from the draw-in and entanglement hazard posed by rotating parts.



### Wear safety boots.

They protect your feet from splintering, falling and flying pieces which could cause injuries.

**Residual risks**

-  **Warning of electrical voltage**  
Electric shock due to insufficient insulation!  
Check the device for damages and proper functioning before each use.  
If you detect damages, do not use the device any longer.  
Do not use the device when either the device or your hands are damp or wet!
-  **Warning of electrical voltage**  
Work on the electrical components must only be carried out by an authorised specialist company!
-  **Warning of electrical voltage**  
Before any work on the device, remove the mains plug from the mains socket and the battery from the device!  
Do not touch the mains plug with wet or damp hands.  
Hold onto the mains plug while pulling the power cable out of the mains socket.
-  **Warning of electrical voltage**  
There is a risk of a short-circuit due to liquids penetrating the housing!  
Do not immerse the device and the accessories in water. Make sure that no water or other liquids can enter the housing.
-  **Warning of explosive substances**  
Do not expose the battery to temperatures above 45 °C! Do not let the battery come into contact with water or fire! Avoid direct sunlight and moisture. There is a risk of explosion!
-  **Warning of hot surface**  
The insertion tool might still be hot after the application. Burn hazard when touching the insertion tool.  
Do not touch the insertion tool bare-handed!  
Wear protective gloves!
-  **Warning**  
Toxic dusts!  
  The harmful / toxic dusts produced during operation pose of risk to the health of the operator and persons in the vicinity.  
Wear eye protection and a dust mask!
-  **Warning**  
Do not process materials containing asbestos. Asbestos is considered carcinogenic.
-  **Warning**  
Make sure not to hit power, gas or water lines when working with a power tool.  
If necessary, use a pipe detector to check the wall you want to drill in or slit open.
-  **Warning**  
Risk of injuries caused by flying parts or bursting tool heads.
-  **Warning**  
Dangers can occur at the device when it is used by untrained people in an unprofessional or improper way! Observe the personnel qualifications!
-  **Warning**  
The device is not a toy and does not belong in the hands of children.
-  **Warning**  
Risk of suffocation!  
Do not leave the packaging lying around. Children may use it as a dangerous toy.
-  **Caution**  
Vibration emissions can cause a health hazard if the device is used for an extended period of time or if it is not properly handled and maintained.
-  **Caution**  
Keep a sufficient distance from heat sources.
- Notice**  
If you store or transport the device improperly, the device may be damaged.  
Note the information regarding transport and storage of the device.

**Behaviour in the event of an emergency / emergency stop function**

Emergency stop:

Removing the battery results in the function of the device stopping immediately. Leave the battery out in order to secure the device against accidental switch-on.

Behaviour in the event of an emergency:

1. Switch the device off.
2. In the event of an emergency, remove the battery from the device: Hold the release button of the battery and pull the battery off the device as described in chapter "Removing the battery".
3. Do not insert the battery if the device is defective.



## Information about the device

### Device description

The device PAGS 21-115 NB is suited for cutting metal and stone materials without the use of water as well as for cutting tiles and concrete blocks.

The on/off switch is provided with a start lock.

The constant rated speed of 10,000 rpm ensures constantly high performance even under load.

The guard can be quickly adjusted without tools.

The spindle lock allows for a simple exchange of discs.

The additional handle can be variably mounted in 3 positions and, in combination with the low level of vibrations, ensures comfortable working.

The face spanner can be stored inside the additional handle.

The device is compatible with the Multiflex battery 20 V 4 Ah and its quick charger Multiflex 20 – 4.0 AC. The battery and the quick charger are not included in the scope of delivery.

### Device depiction

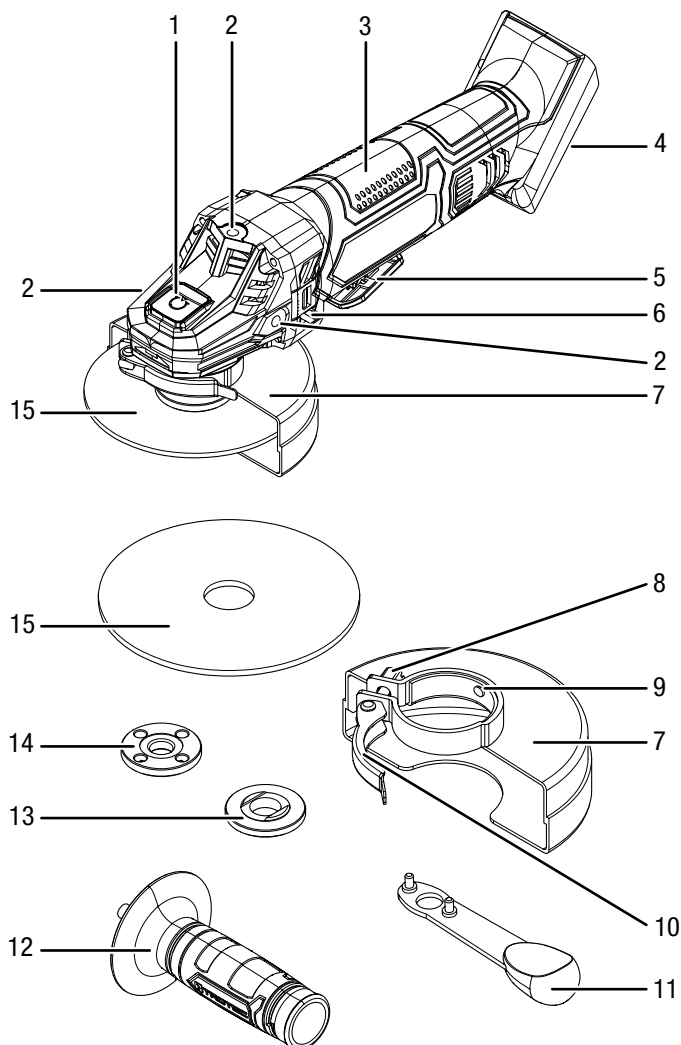



No.	Designation
1	Spindle lock
2	Thread (3 x) for additional handle
3	Device handle
4	Battery holder
5	On/off switch with start lock
6	Venting slots
7	Protective cover
8	Adjusting screw
9	Coded projection
10	Locking lever
11	Face spanner
12	Additional handle
13	Mounting flange
14	Clamping nut
15	Cutting disc

### Scope of delivery

- 1 x Cordless angle grinder PAGS 21-115 NB
- 1 x Cutting disc for metal, cutting disc diameter: 115 mm
- 1 x Guard
- 1 x Additional handle
- 1 x Face spanner
- 1 x Clamping nut
- 1 x Transport case
- 1 x Manual

## Technical data

Parameter	Value
<b>Model</b>	<b>PAGS 21-115 NB</b>
Nominal voltage	20 V $\overline{=}$
Rated no-load speed	10,000 rpm
Spindle thread	M14
Rated capacity	115 mm
Weight	2.55 kg
<b>Cutting disc (scope of delivery)</b>	
Idle speed cutting disc	13,300 rpm
Disc speed	80 m/s
Bore diameter	22.23 mm
Cutting disc thickness	3 mm
<b>Battery</b>	<b>Multiflex 20 – 4.0 DC</b>
Type	Li-ion
Nominal voltage	20 V $\overline{=}$
Nominal capacity	4.0 Ah
Rechargeable cells	10 cells
Capacity	80 Wh
<b>Quick charger</b>	<b>Multiflex 20 – 4.0 AC</b>
Input	
Nominal voltage	230 – 240 V / 50 Hz
Power consumption	94 kW
Output	
Nominal voltage	21.5 V $\overline{=}$
Charging current	3.5 A
Fusing 	3.15 A (slow-blowing)
Charging time	1.5 h
Cable length	1.5 m
Protection class	II (double insulation) / 
<b>Vibration information according to EN 62841</b>	
Vibration emission value main handle $a_{h,co}$	2.6 m/s <sup>2</sup>
Vibration emission value additional handle $a_{h,co}$	1.7 m/s <sup>2</sup>
Uncertainty K main handle / additional handle	1.5 m/s <sup>2</sup>
<b>Sound values according to EN 62841</b>	
Sound pressure level $L_{pA}$	84 dB(A)
Sound power $L_{WA}$	92 dB(A)
Uncertainty K	3 dB



### Wear hearing protection.

Excessive noise can lead to hearing loss.

### Information on noise and vibration:

- The specified total vibration **and noise emission values** were measured by means of a test procedure standardized in EN 62841 and can be consulted for the comparison of one power tool with another.
- The specified total vibration **and noise emission values** can also be used for preliminary load assessment.



### Caution

Vibration emissions can cause a health hazard if the device is used for an extended period of time or if it is not properly handled and maintained.

- The actual vibration **and noise emission** may differ from the stated values during operation of the power tool. This depends on how the power tool is used and especially on the type of workpiece being processed. Try to keep the vibration load to a minimum. Exemplary measures for reducing the vibration load include wearing gloves during operation of the tool and the limitation of working hours. All parts of an operating cycle must be considered for this (e.g. times at which the power tool is switched off and times when it is switched on but runs without load).

## Transport and storage

### Notice

If you store or transport the device improperly, the device may be damaged.

Note the information regarding transport and storage of the device.

### Transport

For transporting the device, use the transport case included in the scope of delivery in order to protect the device from external influences.

**Before** transporting the device, observe the following:

- Switch off the device.
- Hold onto the mains plug while pulling the power cable of the charger out of the mains socket.
- Allow the device to cool down.
- Remove the battery from the device.
- Remove the tool from the tool holder.

The supplied Li-ion batteries are subjects to the requirements of dangerous goods legislation.

Observe the following when transporting or shipping Li-ion batteries:

- The user may transport the batteries by road without any additional requirements.
- If transport is carried out by third parties (e.g. air transport or forwarding company), special requirements as to packaging and labelling must be observed. This includes consulting a dangerous goods specialist when preparing the package.
  - Only ship batteries if their housing is undamaged.
  - Mask open terminals with tape and pack the battery in a way that it cannot move inside the packaging.
  - Please also observe any other national regulations.

### Storage

**Before** storing the device, proceed as follows:

- Switch off the device.
- Hold onto the mains plug while pulling the power cable of the charger out of the mains socket.
- Allow the device to cool down.
- Remove the battery from the device.
- Remove the tool from the tool holder.
- Clean the device as described in the Maintenance chapter.
- For storing the device, use the transport case included in the scope of delivery in order to protect the device from external influences.
- Do not store Li-ion batteries which are completely discharged. Storing discharged batteries can lead to a deep discharge and thus damage the battery.

When the device is not being used, observe the following storage conditions:

- Dry and protected from frost and heat
- Ambient temperature below 45 °C
- Protected from dust and direct sunlight inside the transport case

**Start-up**

**Unpacking the device**

- Take the transport case out of the packaging.



**Warning of electrical voltage**

Electric shock due to insufficient insulation!  
Check the device for damages and proper functioning before each use.

If you detect damages, do not use the device any longer.

Do not use the device when either the device or your hands are damp or wet!

- Check the contents of the transport case for completeness and look for damages.



**Warning**

Risk of suffocation!

Do not leave the packaging lying around. Children may use it as a dangerous toy.

- Dispose of the packaging material according to the national regulations.

**Charging the battery**

**Notice**

The battery can be damaged in case of improper charging.

Remove the charger's mains plug before inserting or removing the battery.

Never charge the battery at ambient temperatures below 10 °C or above 40 °C.

The battery is partially charged upon delivery to avoid damage to the battery caused by a deep discharge.

Prior to initial start-up and when the battery is low (only the red LED in the battery level indication (16) is illuminated), the battery should be charged. To do so, please proceed as follows:

1. Slide the battery (17) onto the quick charger (18) as depicted until the battery locks in place.

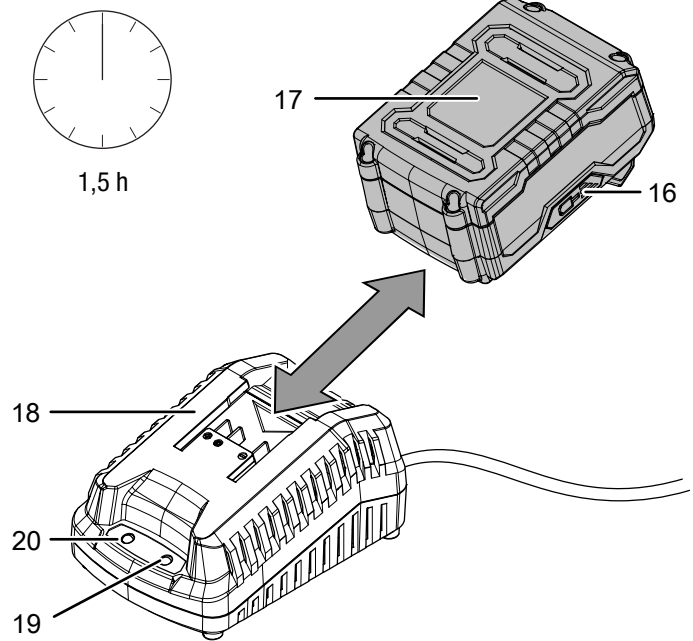

2. Insert the mains plug of the quick charger (18) into a properly fused mains socket.
  - ⇒ The red battery LED (19) lights up.
  - ⇒ Charging requires approx. one and a half hours.
3. Wait until the red battery LED (19) goes off and the green battery LED (20) lights up.
  - ⇒ The battery (17) is fully charged.
4. Hold onto the mains plug while pulling the power cable of the quick charger (18) out of the mains socket.
  - ⇒ The battery (17) and the quick charger (18) may have become warm during charging.
  - Allow the battery (17) to cool down to room temperature.
5. Take the battery (17) out of the quick charger (18) by pressing and holding the release button (21) and pulling the battery (17) off the quick charger (18).

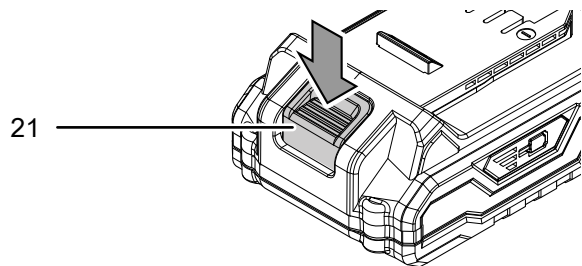

### Inserting the battery

1. Slide the battery (17) into the battery holder (4) until it locks in place.

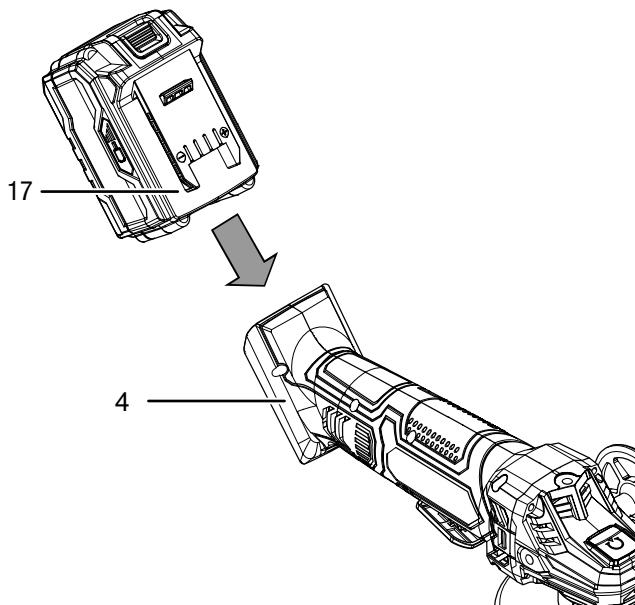

### Removing the battery

1. Detach the battery (17) from the device by pressing and holding the unlocking button (21, I.) and pulling the battery off the device (II.).

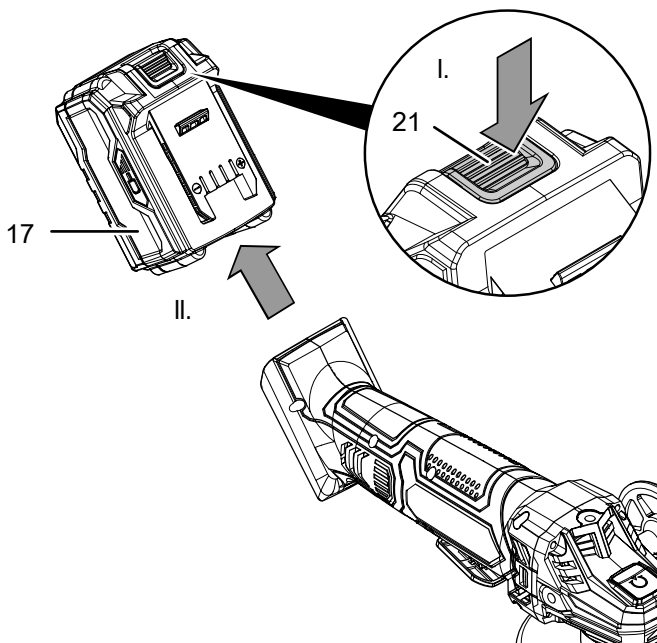

2. If required, charge the battery (17) as described in the section *Charging the battery*.

### Checking the battery charging status

The battery comes with an integrated battery level indication. The battery status is displayed as follows by the three LEDs of the battery level indication (16):

LED colour	Meaning
Green – Orange – Red	maximum charge / power
Orange – Red	medium charge / power
Red	weak charge – recharge the battery

1. Press on the battery icon (23) on the battery (17).  
⇒ You can read the battery status from the battery level indication (16).

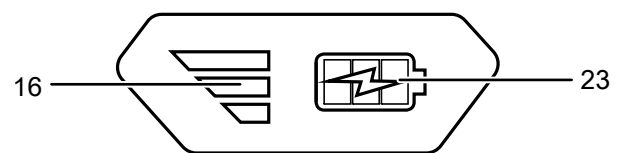

### Mounting the handle



#### Caution

Only use the device with the supplied additional handle.

The additional handle (12) must be mounted before start-up. To do so, please proceed as follows:

1. Screw the additional handle (12) clockwise into the thread (2) either on the right- or left-hand side or on top of the housing.

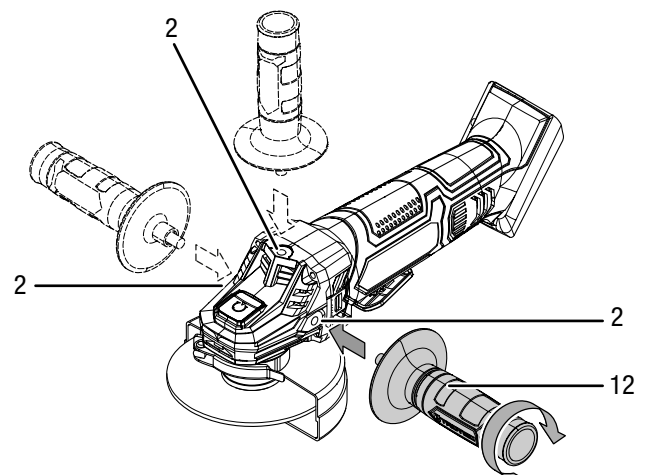

2. Check the additional handle (12) for tight fit.
3. For disassembly unscrew the additional handle (12) counter-clockwise.

**Adjusting the guard**



**Warning of electrical voltage**

Before any work on the device, remove the mains plug from the mains socket and the battery from the device! Hold onto the mains plug while pulling the power cable out of the mains socket.



**Caution**

If you detect damage at the guard, stop using the device.

The guard is preassembled.

Only use the cordless angle grinder with the guard mounted to protect yourself and your environment from flying sparks, detached parts and accidental contact with the cutting disc.

The guard must be adjusted in a way that sparks cannot ignite combustible parts, including those present in the surroundings.

The guard must be adjusted in a way that flying sparks and detached parts cannot hit the user.

To adjust the guard (7), please proceed as follows:

1. Open the locking lever (10).

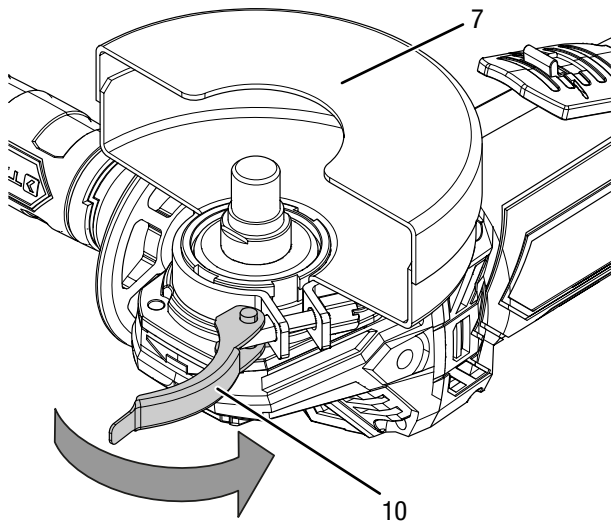

2. Turn the guard (7) into the working position. Make sure that the open side of the guard points towards the workpiece. The closed side of the guard must always point to the user.

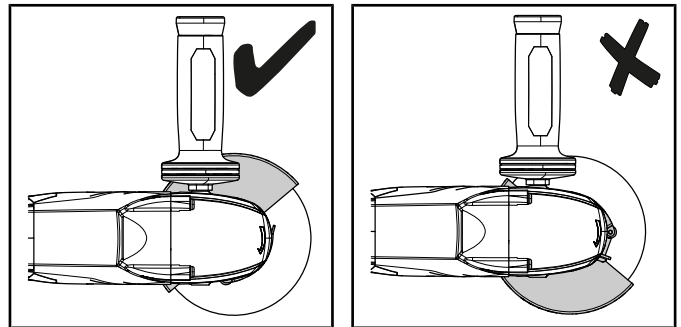
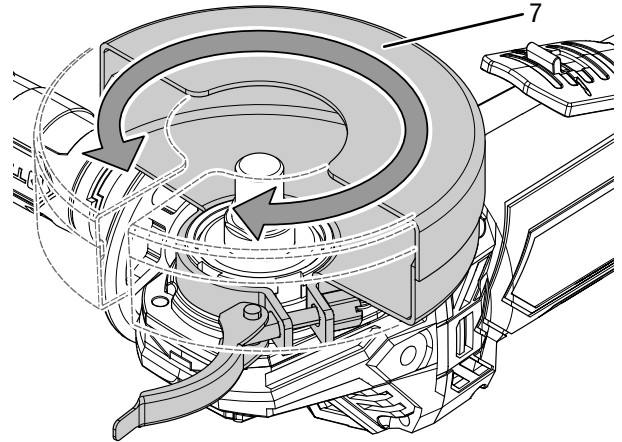

3. Close the locking lever (10).

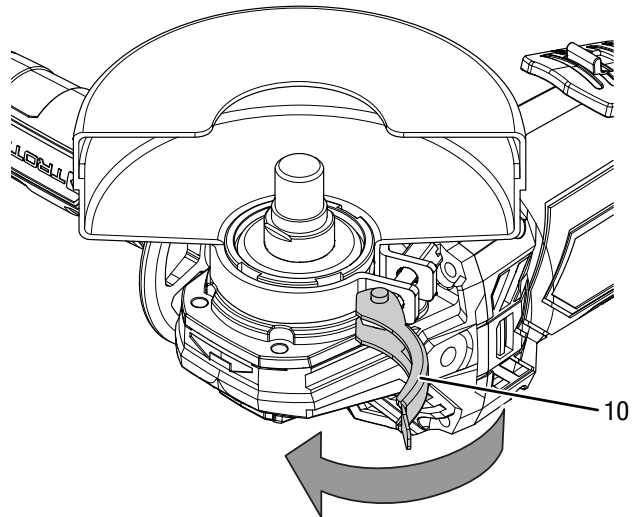

4. Check whether the guard (7) is properly locked in place. It must be impossible to rotate the guard.  
You can increase the clamping force of the lock by tightening the adjusting screw (8).

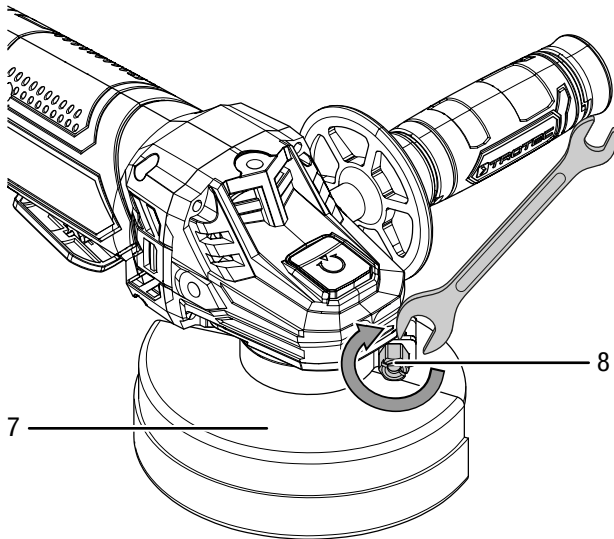

### Tool change

The cutting disc for metal is preassembled.



#### Warning of electrical voltage

Before any work on the device, remove the mains plug from the mains socket and the battery from the device! Hold onto the mains plug while pulling the power cable out of the mains socket.



#### Warning of hot surface

The insertion tool might still be hot after the application. Burn hazard when touching the insertion tool.



Do not touch the insertion tool bare-handed!  
Wear protective gloves!

To change the cutting disc, please proceed as follows:

- ✓ The spindle is at a standstill and the cutting disc is no longer rotating.
1. Remove the battery from the device.
  2. Remove the face spanner (11) from the additional handle (12).

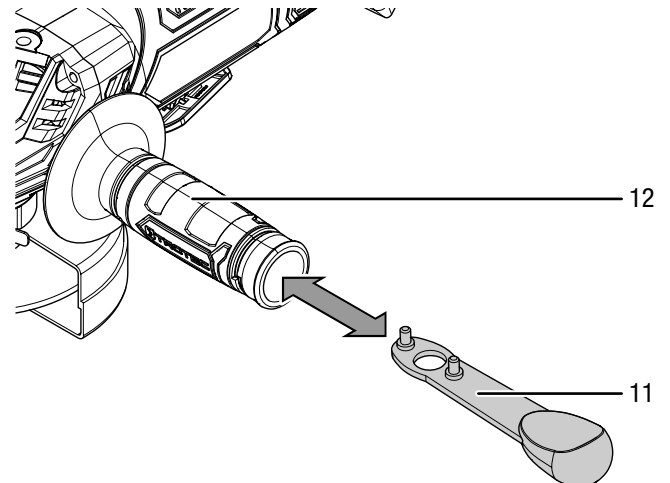

3. Press the spindle lock (1) to block the gears.
4. Slowly turn the clamping nut (14) to the locking point until the lock is fixed. Press and hold the spindle lock (1).
5. Use the face spanner (11) to unscrew the clamping nut (14) counter-clockwise. Then let go of the spindle lock (1).

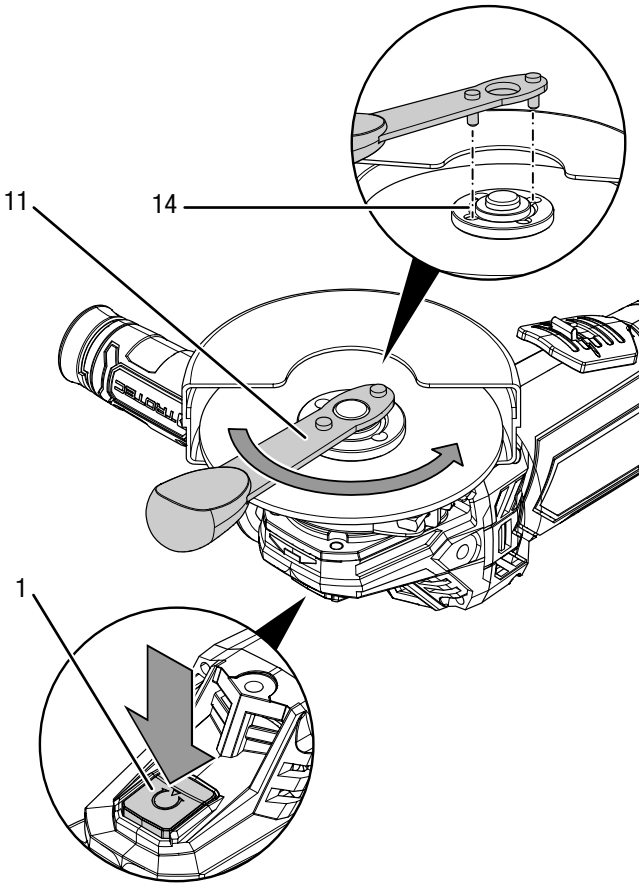

6. Remove the used cutting disc (16). Make sure that the mounting flange (13) is firmly locked in place in the designated recesses.

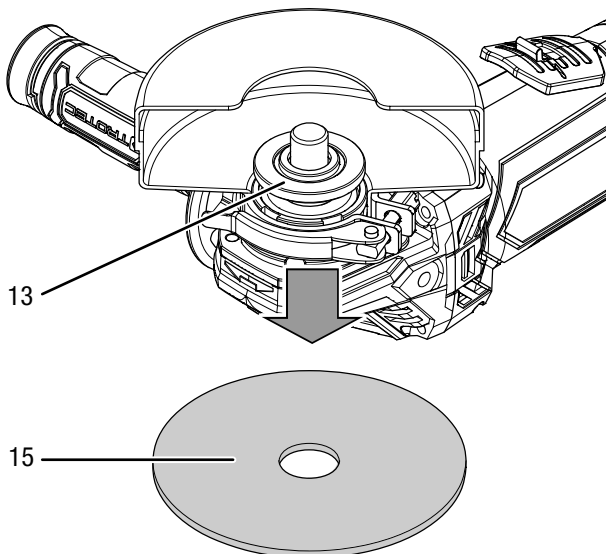

7. Put the cutting disc (15) on the mounting flange (13). The labelling must point to the device. Make sure that the cutting disc hole fits the mounting flange without clearance. Do not use any reducers or adapters.

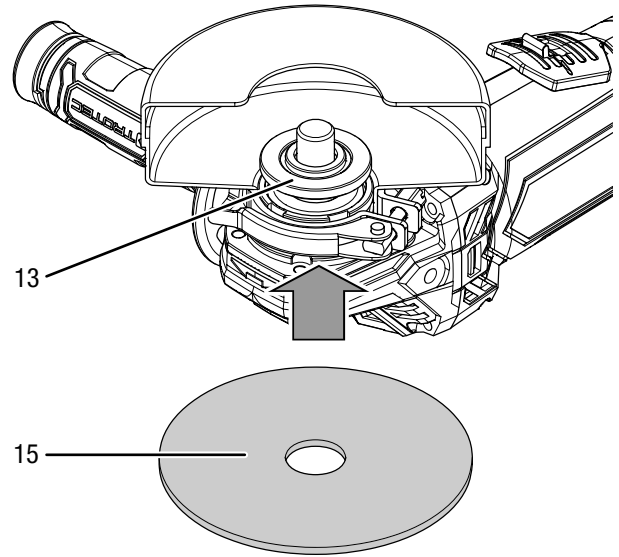

8. Screw the clamping nut (14) back on. The flat side of the clamping nut must point to the device.

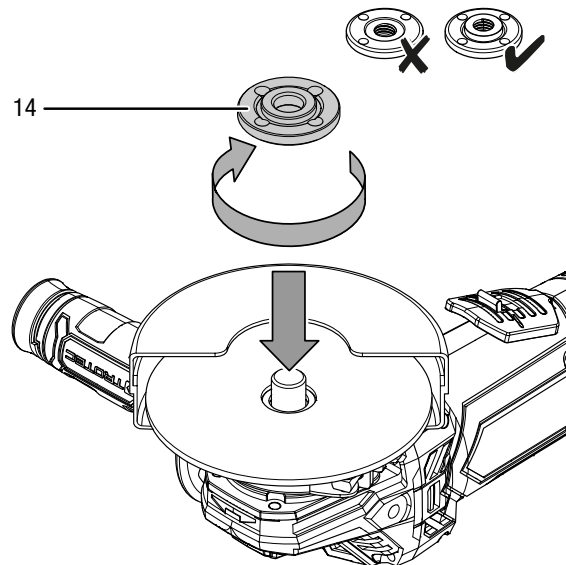



9. Press the spindle lock (1) to lock the gears.
10. Slowly turn the clamping nut (14) to the locking point until the lock is fixed. Press and hold the spindle lock (1).
11. Retighten the clamping nut (14) by means of the face spanner (11). Then let go of the spindle lock (1). Pay attention not to damage the cutting disc.

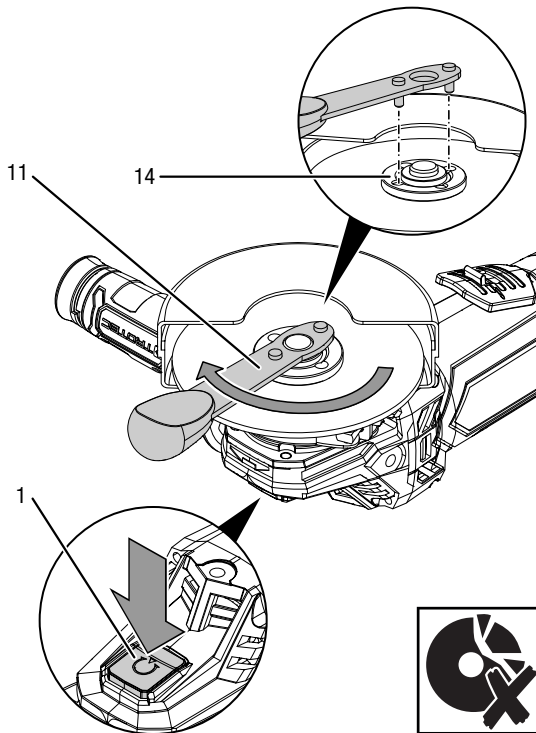

12. Check the cutting disc (15) for proper fit.
13. Check whether the cutting disc can rotate freely. Make sure that the disc does not touch the guard or any other parts.
14. Carry out a test run of approx. 1 minute without load prior to every disc change and every start-up in order to check the cutting disc for correct fit.
15. Put the face spanner (11) back into the additional handle (12) for storage.
16. Put the battery back in.



### Caution

If the disc is out-of-round, rotates unevenly, vibrates, oscillates, or if unusual noises or sparks are generated, the cutting disc must be exchanged immediately. Otherwise, there is a risk of injury.

## Operation

### Tips and notes on handling the cordless angle grinder



**The power tool must always be held with both hands.**

During operation hold onto the power tool's handle and additional handle with both hands and make sure you stand firmly on the ground.

### General information:

- Carry out a test run of approx. 1 minute without load prior to every disc change and every start-up in order to check the cutting disc for correct fit.
- Only use tools which are approved for the device used.
- Before every application, make sure that you have selected the correct tool for the intended use.
- Check the tool in the tool holder for proper fit before every application. The tool must be firmly locked in place in the designated holding fixtures on the tool holder.
- Check whether the cutting disc can rotate freely. Make sure that the disc does not touch the guard or any other parts.
- Only use discs with a speed imprinted that is at least as high as the speed indicated on the device's nameplate.
- Clamp the workpiece unless it is firmly and safely positioned by its own weight.
- Do not overload the device so that it comes to a standstill.
- After operation at high load, let the device run at idle for several minutes to allow the tool to cool down.
- Do not touch the discs until they have cooled down.
- Keep the venting slots clear to prevent the motor from overheating.

### Cutting:

- Only use intact, flawless cutting discs. Bent, blunt or otherwise damaged cutting discs could break.
- Never use the cutting disc for roughing!
- Only advance moderately during operation and make sure that the cutting disc does not get jammed.
- Do not slow down the decelerating cutting disc by pressing against the side of the disc.
- Always move the cutting disc through the workpiece in reverse rotation.
- Hold onto the tool with both hands.
- Maintain a consistent grinding pressure when moving the device back and forth over the area.
- You'll obtain better results if the machining process not only involves one single work cycle, but if you move over the surface several times with the tool. To do so, use a positioning angle of approx. 30°.

**Switching the device on and off**

Wear your personal protective equipment when working with the device.

1. Check whether the mounted cutting disc is suitable for the intended application.
2. Check whether the workpiece is secured and the worktop prepared correspondingly.
3. Slide back the start lock (22) at the on/off switch (5).
4. Press the on/off switch (5) and hold it during operation.

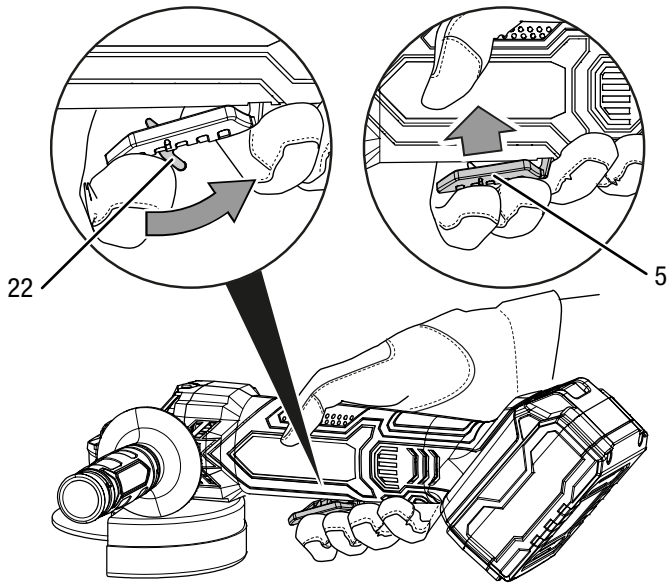

5. Carry out a test run of approx. 1 minute without load prior to every disc change and every start-up in order to check the cutting disc for correct fit.
6. After switch-on, wait until the device has reached its maximum speed. Only then start working.

7. To switch the device off, let go of the on/off switch (5).



**Caution**

The disc keeps running after the device has been switched off.  
Risk of injury.

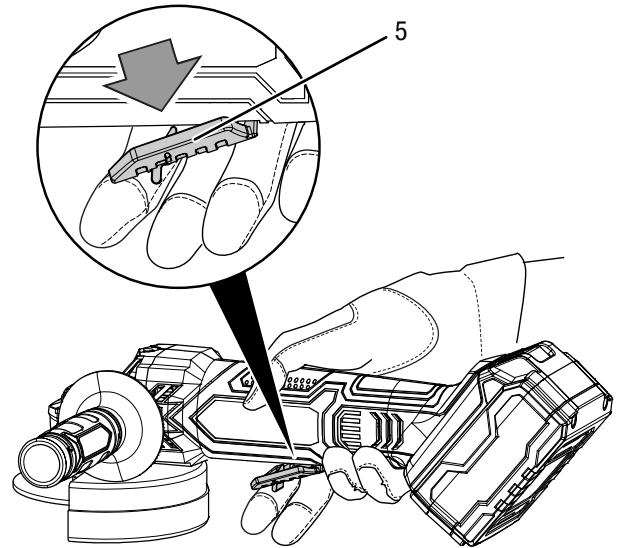

**Shutdown**



**Warning of electrical voltage**

Do not touch the mains plug with wet or damp hands.

- Switch off the device.
- Hold onto the mains plug while pulling the power cable of the charger out of the mains socket.
- If required, allow the device to cool down.
- Remove the battery from the device (see Start-up chapter).
- Remove the tool from the device (see Start-up chapter).
- Clean the device according to the Maintenance chapter.
- Store the device according to the Transport and storage chapter.

**Available accessories**



**Warning**

Only use accessories and additional equipment specified in the instructions.  
Using insertion tools or accessories other than those specified in the instructions may cause a risk of injury.

Designation	Article number
Set of diamond cutting discs Ø 110 mm / 115 mm	6.225.001.121
Spare battery Multiflex 4.0 Ah 20V	6.200.000.320
Charger for spare battery Multiflex 4.0 Ah 20V	7.430.001.265

## Errors and faults

The device has been checked for proper functioning several times during production. If malfunctions occur nonetheless, check the device according to the following list.

Troubleshooting tasks which require the housing to be opened must only be carried out by an authorized specialist electrical company or by the manufacturer.

### Notice

Wait for at least 3 minutes after maintenance and repair work. Only then switch the device back on.

### Light smoke or odour is emitted during the first use:

- This is not a fault. These phenomena disappear after a brief runtime.

### The battery does not charge:

- Check whether the battery is correctly connected to the quick charger.  
Slide the battery into the quick charger in a way that the battery terminals engage in the quick charger. The battery must lock in place in the quick charger.
- Check the power connection.
- Check the power cable and mains plug for damages.
- Check the fuse (home).
- Check the quick charger for damages. Should the quick charger be damaged, stop using it. Contact the Trotec customer service.
- Check the battery terminals for dirt. Remove any dirt.
- The battery might be defective and have to be replaced. Only use batteries of the same type.

### The device does not start:

- The battery power might be too low. Recharge the battery.
- Check whether the battery is correctly connected to the device.  
Slide the battery onto the device in a way that the battery terminals engage. The battery must lock in place in the device.
- Check the battery terminals for dirt. Remove any dirt.

### The cutting disc is loose:

- Check whether you are using a cutting disc that is suited for this device.
- Make sure that the mounting flange is firmly locked in place in the designated recesses.
- Make sure that the cutting disc sits flush on the mounting flange without clearance.
- Make sure that the flat side of the clamping nut rests on the cutting disc.

### The guard is loose:

- Make sure that the coded projections are firmly locked in place in the designated groove.
- Make sure that the locking lever is folded in completely.
- If necessary, tighten the adjusting screw.

### The cutting disc does not move although the motor is running:

- Make sure that the clamping nut is firmly tightened, see chapter Tool change.
- Make sure that there is no workpiece debris blocking the drive. Remove the blockages, if any.
- Make sure that the cutting disc is not jammed in the workpiece.

### The motor slows down:

- Check whether the device is overloaded by the workpiece.
- Reduce the pressure applied on the workpiece.
- Check whether the workpiece is suitable for the tasks to be carried out.

### The cutting disc experiences difficulties penetrating the material to be processed or the cutting performance is insufficient:

- Check whether the chosen cutting disc is suitable for the material to be processed.
- If the cutting disc is worn, replace it with a new one.

### The device becomes hot:

- Check whether the cutting disc is suitable for the tasks to be carried out.
- Make sure not to exert too much pressure on the device during operation.
- Keep the venting slots clear to prevent the motor from overheating.

### The device still does not operate correctly after these checks:

Please contact the customer service. If necessary, bring the device to an authorised specialist electrical company or to the manufacturer for repair.

## Maintenance

### Activities required before starting maintenance



#### Warning of electrical voltage

Do not touch the mains plug or the battery with wet or damp hands.

- Switch the device off.
- Allow the device to cool down completely.
- Remove the battery from the device.



#### Warning of electrical voltage

**Maintenance tasks which require the housing to be opened must only be carried out by authorised specialist companies or by the manufacturer.**

### Notes on maintenance

Inside the device, there are no parts that need to be maintained or lubricated by the user.

### Safety signs on the battery and the charger

Check the safety signs attached to the battery and the charger at regular intervals. Replace illegible safety signs!

### Cleaning

The device should be cleaned before and after each use.

#### Notice

The device does not have to be lubricated after cleaning.



#### Warning of electrical voltage

There is a risk of a short-circuit due to liquids penetrating the housing!

Do not immerse the device and the accessories in water. Make sure that no water or other liquids can enter the housing.

- Clean the device with a soft, damp and lint-free cloth. Make sure that no moisture enters the housing. Protect electrical components from moisture. Do not use any aggressive cleaning agents such as cleaning sprays, solvents, alcohol-based or abrasive cleaners to dampen the cloth.
- Dry the device with a soft, lint-free cloth.
- Remove dust from inside the guard, from the mounting flange and from the clamping nut.
- Keep the connecting terminals on the device and charger clean.
- Keep the connecting terminals on the battery pack clean.
- Keep the ventilation openings free from dust deposits to prevent overheating of the motor.
- For maintenance of the cutting disc, see chapter Tool change.

## Disposal

Always dispose of packing materials in an environmentally friendly manner and in accordance with the applicable local disposal regulations.



The icon with the crossed-out wheeled bin indicates that this device and any associated components (e.g. remote controls) must not be disposed of with household waste at the end of their life, in accordance with the Waste Electrical and Electronic Equipment Directive (2012/19/EU) and national laws.

You will find collection points for free return of waste electrical and electronic equipment in your vicinity. The addresses can be obtained from your municipality or local administration. You can also find out about other return options that apply for many EU countries on the website <https://hub.trotec.com/?id=45090>. Otherwise, please contact an official recycling centre for electronic and electrical equipment authorised for your country.

The separate collection of waste electrical and electronic equipment aims to enable the re-use, recycling and other forms of recovery of waste equipment as well as to prevent negative effects for the environment and human health caused by the disposal of hazardous substances potentially contained in the equipment.



This icon with the crossed-out wheeled bin indicates that lithium-ion batteries must not be disposed of with household waste at the end of their life. To prevent environmental pollution, do not carelessly leave batteries or electrical and electronic equipment containing batteries in public areas. In the European Union, batteries and accumulators must be returned to a designated collection point in accordance with REGULATION (EU) 2023/1542 OF THE EUROPEAN PARLIAMENT AND OF THE COUNCIL of 12 July 2023 concerning batteries and waste batteries. Remove batteries/accumulators and dispose of them separately according to the relevant legal requirements.

### Only for United Kingdom

According to Waste Electrical and Electronic Equipment Regulations 2013 (SI 2013/3113) (as amended) and the Waste Batteries and Accumulators Regulations 2009 (SI 2009/890) (as amended), devices that are no longer usable must be collected separately and disposed of in an environmentally friendly manner.

## EU Declaration of Conformity (original)

Declaration of conformity in accordance with the EC Machinery Directive 2006/42/EC, Annex II, Part 1, Section A

We – Trotec GmbH – declare in sole responsibility that the product designated below was developed, constructed and produced in compliance with all relevant provisions of the EC Radio Equipment Directive in the version 2006/42/EC.

**Product model / Product:** PAGS 21-115 NB

**Product type:** cordless angle grinder

**Year of manufacture as of:** 2024

**The product also complies with all relevant provisions of the following directives/regulations:**

- 2011/65/EU
- 2014/30/EU

**Relevant EU directives:**

- 2012/19/EU
- 2015/863/EU

**Applied harmonised standards:**

- EN 62841-1:2015  
EN 62841-1:2015/AC:2015  
EN 62841-1:2015/A11:2022
- EN IEC 62841-2-3:2021  
EN IEC 62841-2-3:2021/A11:2021

**Applied national standards and technical specifications:**

- EN IEC 55014-1:2021
- EN IEC 55014-2:2021

**Manufacturer and name of the authorised representative of the technical documentation:**

Trotec GmbH

Grebener Straße 7, D-52525 Heinsberg

Phone: +49 2452 962-400

E-mail: info@trotec.de

Place and date of issue:

Heinsberg, 02.01.2024



Joachim Ludwig, Managing Director

Trotec GmbH

Grebbener Str. 7  
D-52525 Heinsberg

☎ +49 2452 962-400

☎ +49 2452 962-200

✉ [info@trotec.com](mailto:info@trotec.com)

[www.trotec.com](http://www.trotec.com)