

EN

ORIGINAL INSTRUCTIONS
CORDLESS ANGLE GRINDER



Table of contents

Notes regarding the instructions 1

Safety 2

Information about the device 8

Transport and storage 10

Start-up 11

Operation 17

Available accessories 18

Errors and faults 18





Maintenance 19

Disposal 20

Declaration of conformity 20

Notes regarding the instructions

Symbols

-  **Warning of electrical voltage**
This symbol indicates dangers to the life and health of persons due to electrical voltage.
-  **Warning of explosive substances**
This symbol indicates dangers to the life and health of persons due to potentially explosive substances.
-  **Warning of hot surface**
This symbol indicates dangers to the life and health of persons due to hot surface.
-  **Warning**
This signal word indicates a hazard with an average risk level which, if not avoided, can result in serious injury or death.
-  **Caution**
This signal word indicates a hazard with a low risk level which, if not avoided, can result in minor or moderate injury.

 **Not permissible for wet grinding**
Information marked with this symbol indicates that wet grinding is prohibited.

Note
This signal word indicates important information (e.g. material damage), but does not indicate hazards.

 **Info**
Information marked with this symbol helps you to carry out your tasks quickly and safely.

 **Follow the manual**
Information marked with this symbol indicates that the operating manual must be observed.

 **Wear head protection**
Information marked with this symbol indicates that you should wear protective headgear.

 **Wear hearing protection**
Information marked with this symbol indicates that you should wear hearing protection.

 **Wear safety glasses**
Information marked with this symbol indicates that you should wear eye protection.

 **Wear a protective mask**
Information marked with this symbol indicates that you should wear a protective mask.

 **Wear protective clothing**
Information marked with this symbol indicates that you should wear protective clothing.

 **Wear protective gloves**
Information marked with this symbol indicates that you should wear protective gloves.

 **Wear foot protection**
Information marked with this symbol indicates that you should wear safety boots.

 **Do not use damaged discs**
This symbol indicates that the device must not be operated with faulty accessories.

 **Accessory suited for metallic materials**
This symbol indicates that the supplied accessory is **only** to be used for metal.



Accessory not suitable for roughing operations

This symbol indicates that the supplied accessory must **not** to be used for roughing.



Accessory suited for cutting operations

This symbol indicates that the supplied accessory may be used for cutting.

You can download the current version of the operating manual and the EU declaration of conformity via the following link:



PAGS 20-115



<https://hub.trotec.com/?id=41427>

Safety

Read this manual carefully before starting or using the device. Always store the manual in the immediate vicinity of the device or its site of use!



Warning

Observe all the safety warnings, instructions, illustrations and technical data provided with this power tool.

Failure to follow the instructions below may result in electric shock, fire and / or serious injury.

Save all warnings and instructions for future reference.

The term *power tool* used in the safety warnings refers to both mains-operated and battery-powered electric tools (with/without power cable).



General Power Tool Safety Warnings – Work area safety

- **Keep work area clean and well lit.** Cluttered or dark areas invite accidents.
- **Do not operate power tools in explosive atmospheres, such as in the presence of flammable liquids, gases or dust.** Power tools create sparks which may ignite the dust or fumes.
- **Keep children and bystanders away while operating a power tool.** Distractions can cause you to lose control.



General Power Tool Safety Warnings – Electrical safety

- **Power tool plugs must match the outlet. Never modify the plug in any way. Do not use any adapter plugs with earthed (grounded) power tools.** Unmodified plugs and matching outlets will reduce risk of electric shock.
- **Avoid body contact with earthed or grounded surfaces, such as pipes, radiators, ranges and refrigerators.** There is an increased risk of electric shock if your body is earthed or grounded.
- **Do not expose power tools to rain or wet conditions.** Water entering a power tool will increase the risk of electric shock.
- **Do not abuse the cord. Never use the cord for carrying, pulling or unplugging the power tool. Keep the cord away from heat, oil, sharp edges or moving parts.** Damaged or entangled cords increase the risk of electric shock.
- **When operating a power tool outdoors, use an extension cord suitable for outdoor use.** Use of a cord suitable for outdoor use reduces the risk of electric shock.
- **If operating a power tool in a damp location is unavoidable, use a residual current device (RCD) protected supply.** Use of an RCD reduces the risk of electric shock.



General Power Tool Safety Warnings – Personal safety

- **Stay alert, watch what you are doing and use common sense when operating a power tool. Do not use a power tool while you are tired or under the influence of drugs, alcohol or medication.** A moment of inattention while operating power tools may result in serious personal injury.



Use personal protective equipment. Always wear eye protection. Protective equipment such as dust mask, non-skid safety shoes, hard hat, or hearing protection used for appropriate conditions will reduce personal injuries.

- **Prevent unintentional starting. Ensure the switch is in the off-position before connecting to power source and/or battery pack, picking up or carrying the tool.** Carrying power tools with your finger on the switch or energising power tools that have the switch on invites accidents.
- **Remove any adjusting key or wrench before turning the power tool on.** A wrench or a key left attached to a rotating part of the power tool may result in personal injury.

- **Do not overreach. Keep proper footing and balance at all times.** This enables better control of the power tool in unexpected situations.
- **Dress properly. Do not wear loose clothing or jewellery. Keep your hair and clothing away from moving parts.** Loose clothes, jewellery or long hair can be caught in moving parts.
- **If devices are provided for the connection of dust extraction and collection facilities, ensure these are connected and properly used.** The use of a dust extraction system may reduce dust-related hazards.
- **Do not let familiarity gained from frequent use of tools allow you to become complacent and ignore tool safety principles.** A careless action can cause severe injury within a fraction of a second.



General Power Tool Safety Warnings – Power tool use and care

- **Do not force the power tool. Use the correct power tool for your application.** The correct power tool will do the job better and safer at the rate for which it was designed.
- **Do not use the power tool if the switch does not turn it on and off.** Any power tool that cannot be controlled with the switch is dangerous and must be repaired.
- **Disconnect the plug from the power source and / or the battery pack, if detachable, from the power tool before making any adjustments, changing accessories, or storing power tools.** Such preventive safety measures reduce the risk of starting the power tool accidentally.
- **Store idle power tools out of the reach of children and do not allow persons unfamiliar with the power tool or these instructions to operate the power tool.** Power tools are dangerous in the hands of untrained users.
- **Maintain power tools and accessories carefully. Check for misalignment or binding of moving parts, breakage of parts and any other condition that may affect the power tool's operation. If damaged, have the power tool repaired before use.** Many accidents are caused by poorly maintained power tools.
- **Keep cutting tools sharp and clean.** Properly maintained cutting tools with sharp cutting edges are less likely to bind and are easier to control.
- **Use the power tool, accessories and tool bits etc. in accordance with these instructions, taking into account the working conditions and the work to be performed.** Use of the power tool for operations different from those intended could result in a hazardous situation.

- **Keep handles and gripping surfaces dry, clean and free from oil and grease.** Slippery handles and gripping surfaces do not allow for safe handling and control of the tool in unexpected situations.



General Power Tool Safety Warnings – Battery tool use and care

- **Recharge only with the charger specified by the manufacturer.** A charger that is suitable for one type of battery pack may create a risk of fire when used with another battery pack.
- **Use power tools only with specifically designated battery packs.** Use of any other battery packs may create a risk of injury and fire.
- **When battery pack is not in use, keep it away from other metal objects, like paper clips, coins, keys, nails, screws or other small metal objects, that can make a connection from one terminal to another.** Shorting the battery terminals together may cause burns or a fire.
- **Under abusive conditions, liquid may be ejected from the battery. Avoid contact. If contact accidentally occurs, flush with water. If liquid contacts eyes, additionally seek medical help.** Liquid ejected from the battery may cause irritation or burns.
- **Do not use a damaged or modified battery.** Damaged or modified batteries can behave unexpectedly and lead to fires, explosions or injuries.
- **Do not expose a battery to fire or excessively high temperatures.** Exposure to fire or temperatures above 130 °C (265 °F) may cause an explosion.
- **Follow all the instructions for charging and never charge the battery or the cordless tool outside the temperature range specified in the operating instructions.** Incorrect charging or charging outside of the permissible temperature range can destroy the battery and increase the risk of fire.



General Power Tool Safety Warnings – Service

- **Have your power tool serviced by a qualified repair person using only identical replacement parts.** This will ensure that the safety of the power tool is maintained.
- **Never service damaged battery packs.** Service of battery packs should only be performed by the manufacturer or authorized service providers.



Safety Warnings Common for Grinding, Sanding, Wire Brushing or Abrasive Cutting-Off Operations

- **This power tool is intended to function as a grinder, sander, wire brush or cut-off tool.** Read all safety warnings, instructions, illustrations and specifications provided with this power tool. Failure to follow all instructions listed below may result in electric shock, fire and / or serious injury.
- **Operations such as polishing are not recommended to be performed with this power tool.** Operations for which the power tool was not designed may create a hazard and cause personal injury.
- **Do not use accessories which are not specifically designed and recommended by the tool manufacturer.** Just because the accessory can be attached to your power tool, it does not assure safe operation.
- **The rated speed of the accessory must be at least equal to the maximum speed marked on the power tool.** Accessories running faster than their rated speed can break and fly apart.
- **The outside diameter and the thickness of your accessory must be within the capacity rating of your power tool.** Incorrectly sized accessories cannot be adequately guarded or controlled.
- **Threaded mounting of accessories must match the grinder spindle thread. For accessories mounted by flanges, the arbour hole of the accessory must fit the locating diameter of the flange.** Accessories that do not match the mounting hardware of the power tool will run out of balance, vibrate excessively and may cause loss of control.
- **Do not use a damaged accessory. Before each use inspect the accessory such as abrasive wheels for chips and cracks, backing pad for cracks, tear or excess wear, wire brush for loose or cracked wires. If power tool or accessory is dropped, inspect for damage or install an undamaged accessory. After inspecting and installing an accessory, position yourself and bystanders away from the plane of the rotating accessory and run the power tool at maximum no-load speed for one minute.** Damaged accessories will normally break apart during this test time.
- **Wear personal protective equipment. Depending on application, use face shield, safety goggles or safety glasses. As appropriate, wear dust mask, hearing protectors, gloves and workshop apron capable of stopping small abrasive or workpiece fragments.** The eye protection must be capable of stopping flying debris generated by various operations. The dust mask or respirator must be capable of filtrating particles generated by your operation. Prolonged exposure to high intensity noise may cause hearing loss.
- **Keep bystanders a safe distance away from work area. Anyone entering the work area must wear personal protective equipment.** Fragments of workpiece or of a broken accessory may fly away and cause injury beyond immediate area of operation.
- **Hold the power tool by insulated gripping surfaces only, when performing an operation where the cutting accessory may contact hidden wiring or its own cord.** Cutting accessory contacting a "live" wire may make exposed metal parts of the power tool "live" and could give the operator an electric shock.
- **Position the cord clear of the spinning accessory.** If you lose control, the cord may be cut or snagged and your hand or arm may be pulled into the spinning accessory.
- **Never lay the power tool down until the accessory has come to a complete stop.** The spinning accessory may grab the surface and pull the power tool out of your control.
- **Do not run the power tool while carrying it at your side.** Accidental contact with the spinning accessory could snag your clothing, pulling the accessory into your body.
- **Regularly clean the power tool's air vents.** The motor's fan will draw the dust inside the housing and excessive accumulation of powdered metal may cause electrical hazards.
- **Do not operate the power tool near flammable materials.** Sparks could ignite these materials.
- **Do not use accessories that require liquid coolants.** Using water or other liquid coolants may result in electrocution or shock.



Kickback and Related Warnings

Kickback is a sudden reaction to a pinched or snagged rotating wheel, backing pad, brush or any other accessory. Pinching or snagging causes rapid stalling of the rotating accessory which in turn causes the uncontrolled power tool to be forced in the direction opposite of the accessory's rotation at the point of the binding.

For example, if an abrasive wheel is snagged or pinched by the workpiece, the edge of the wheel that is entering into the pinch point can dig into the surface of the material causing the wheel to climb out or kick out. The wheel may either jump toward or away from the operator, depending on direction of the wheel's movement at the point of pinching. Abrasive wheels may also break under these conditions.

Kickback is the result of power tool misuse and/or incorrect operating procedures or conditions and can be avoided by taking proper precautions as given below.

- **Maintain a firm grip on the power tool and position your body and arm to allow you to resist kickback forces. Always use auxiliary handle, if provided, for maximum control over kickback or torque reaction during start-up.** The operator can control torque reactions or kickback forces, if proper precautions are taken.
- **Never place your hand near the rotating accessory.** Accessory may kickback over your hand.
- **Do not position your body in the area where power tool will move if kickback occurs.** Kickback will propel the tool in direction opposite to the wheel's movement at the point of snagging.
- **Use special care when working corners, sharp edges etc. Avoid bouncing and snagging the accessory.** Corners, sharp edges or bouncing have a tendency to snag the rotating accessory and cause loss of control or kickback.
- **Do not attach a saw chain woodcarving blade or toothed saw blade.** Such blades create frequent kickback and loss of control.



Safety Warnings Specific for Grinding and Abrasive Cutting-Off Operations

- **Use only wheel types that are recommended for your power tool and the specific guard designed for the selected wheel.** Wheels for which the power tool was not designed cannot be adequately guarded and are unsafe.
- **The grinding surface of centre depressed wheels must be mounted below the plane of the guard lip.** An improperly mounted wheel that projects through the plane of the guard lip cannot be adequately protected.

- **The guard must be securely attached to the power tool and positioned for maximum safety, so the least amount of wheel is exposed towards the operator.** The guard helps to protect operator from broken wheel fragments and accidental contact with wheel.
- **Wheels must be used only for recommended applications. For example: do not grind with the side of cut-off wheel.** Abrasive cut-off wheels are intended for peripheral grinding, side forces applied to these wheels may cause them to shatter.
- **Always use undamaged wheel flanges that are of correct size and shape for your selected wheel.** Proper wheel flanges support the wheel thus reducing the possibility of wheel breakage. Flanges for cut-off wheels may be different from grinding wheel flanges.
- **Do not use worn down wheels from larger power tools.** Wheel intended for larger power tool is not suitable for the higher speed of a smaller tool and may burst.



Additional Safety Warnings Specific for Abrasive Cutting-Off Operations

- **Do not "jam" the cut-off wheel or apply excessive pressure. Do not attempt to make an excessive depth of cut.** Overstressing the wheel increases the loading and susceptibility to twisting or binding of the wheel in the cut and the possibility of kickback or wheel breakage.
- **Do not position your body in line with and behind the rotating wheel.** When the wheel, at the point of operation, is moving away from your body, the possible kickback may propel the spinning wheel and the power tool directly at you.
- **When wheel is binding or when interrupting a cut for any reason, switch off the power tool and hold the power tool motionless until the wheel comes to a complete stop. Never attempt to remove the cut-off wheel from the cut while the wheel is in motion otherwise kickback may occur.** Investigate and take corrective action to eliminate the cause of wheel binding.
- **Do not restart the cutting operation in the workpiece. Let the wheel reach full speed and carefully re-enter the cut.** The wheel may bind, walk up or kickback if the power tool is restarted in the workpiece.
- **Support panels or any oversized workpiece to minimize the risk of wheel pinching and kickback.** Large workpieces tend to sag under their own weight. Supports must be placed under the workpiece near the line of cut and near the edge of the workpiece on both sides of the wheel.

- **Use extra caution when making a "pocket cut" into existing walls or other blind areas.** The protruding wheel may cut gas or water pipes, electrical wiring or objects that can cause kickback.



Safety Warnings Specific for Sanding Operations

- **Do not use excessively oversized sanding disc paper. Follow manufacturers recommendations, when selecting sanding paper.** Larger sanding paper extending beyond the sanding pad presents a laceration hazard and may cause snagging, tearing of the disc or kickback.



Safety Warnings Specific for Wire Brushing Operations

- **Be aware that wire bristles are thrown by the brush even during ordinary operation. Do not overstress the wires by applying excessive load to the brush.** The wire bristles can easily penetrate light clothing and/or skin.
- **If the use of a guard is recommended for wire brushing, do not allow any interference of the wire wheel or brush with the guard.** Wire wheel or brush may expand in diameter due to work load and centrifugal forces.



Device-specific safety warnings for angle grinders

- **Use suitable detectors to determine if utility lines are hidden in the work area or call the local utility company for assistance.** Contact with electrical lines may result in fire and electric shock. Damaging a gas line may lead to an explosion. Penetrating a water line causes property damage and may cause an electric shock.
- **Do not touch the abrasive wheels and cutting discs until they have cooled down.** The wheels and discs become very hot during operation.
- **Secure the workpiece.** The grip of tensioning devices or a vice is more secure than holding the workpiece only by hand.

Intended use

Only use the device PAGS 20-115:

- for cutting, grinding and brushing metal as well as stone materials without the use of water.
- for cutting tiles and concrete blocks. When cutting stone, an adequate dust extraction system must be provided.

We recommend using the power tool with original Trotec accessories.

Improper use

- Operations such as polishing are not recommended to be performed with this power tool.
- Do not use accessories that require liquid coolants.

Personnel qualifications

People who use this device must:

- have read and understood the operating manual, especially the Safety chapter.

Personal protective equipment



Wear protective headgear.

With it you protect your head from splintering, falling and flying pieces which could cause injuries.



Wear hearing protection.

Excessive noise can lead to hearing loss.



Wear eye protection.

With it you protect your eyes from splintering, falling and flying pieces which could cause injuries.



Wear a protective mask.

It saves you from inhaling harmful dusts generated when processing workpieces.



Wear protective gloves.

They protect your hands from burns, crushing injuries and skin abrasions.



Wear tight-fitting protective clothing.



















This protects you from the draw-in and entanglement hazard posed by rotating parts.



Wear safety boots.

They protect your feet from splintering, falling and flying pieces which could cause injuries.

Residual risks

-  **Warning of electrical voltage**
Electric shock from insufficient insulation.
Check the device for damages and proper functioning before each use.
If you notice damages, no longer use the device.
Do not use the device when the device or your hands are damp or wet!
-  **Warning of electrical voltage**
Work on the electrical components must only be carried out by an authorised specialist company!
-  **Warning of electrical voltage**
Before any work on the device, remove the mains plug from the mains socket and the battery from the device!
Hold onto the mains plug while pulling the power cable out of the mains socket.
-  **Warning of electrical voltage**
There is a risk of a short-circuit due to liquids penetrating the housing!
Do not immerse the device and the accessories in water. Make sure that no water or other liquids can enter the housing.
-  **Warning of explosive substances**
Do not expose the battery to temperatures above 45 °C! Do not let the battery come into contact with water or fire! Avoid direct sunlight and moisture. There is a risk of explosion!
-  **Warning of hot surface**
 The insertion tool might still be hot after the application. Burn hazard when touching the insertion tool.
Do not touch the insertion tool bare-handed!
Wear protective gloves!
-  **Warning**
Toxic dusts!
  The harmful / toxic dusts produced during operation pose of risk to the health of the operator and persons in the vicinity.
Wear eye protection and a dust mask!
-  **Warning**
Do not process materials containing asbestos. Asbestos is considered carcinogenic.
-  **Warning**
Make sure not to hit power, gas or water lines when working with a power tool.
If necessary, use a pipe detector to check the wall you want to drill in or slit open.
-  **Warning**
Risk of injuries caused by flying parts or bursting tool heads.
-  **Warning**
Dangers can occur at the device when it is used by untrained people in an unprofessional or improper way! Observe the personnel qualifications!
-  **Warning**
The device is not a toy and does not belong in the hands of children.
-  **Warning**
Risk of suffocation!
Do not leave the packaging lying around. Children may use it as a dangerous toy.
-  **Warning**
The tool holder must be firmly locked in place before switching the device on, for an insufficiently or incorrectly clamped accessory could be catapulted out of the tool holder uncontrollably upon switch-on.
-  **Caution**
Vibration emissions can cause a health hazard if the device is used for an extended period of time or if it is not properly handled and maintained.
-  **Caution**
Keep a sufficient distance from heat sources.
- Note**
If you store or transport the device improperly, the device may be damaged.
Note the information regarding transport and storage of the device.

Information about the device

Device description

The device PAGS 20-115 is suited for cutting, grinding and brushing metal and stone materials without the use of water as well as for cutting tiles and concrete blocks.

The on/off switch is provided with a start lock.

The constant rated speed of 10,000 rpm ensures constantly high performance even under load.

The guard can be quickly adjusted without tools.

The spindle lock allows for a simple exchange of discs.

The additional handle can be variably mounted in 3 positions and, in combination with the low level of vibrations, ensures comfortable working.

The face spanner can be stored inside the additional handle.

The battery comes with its own battery level indication. As a result you can check the current charging status without having to connect it to the device.

Device depiction

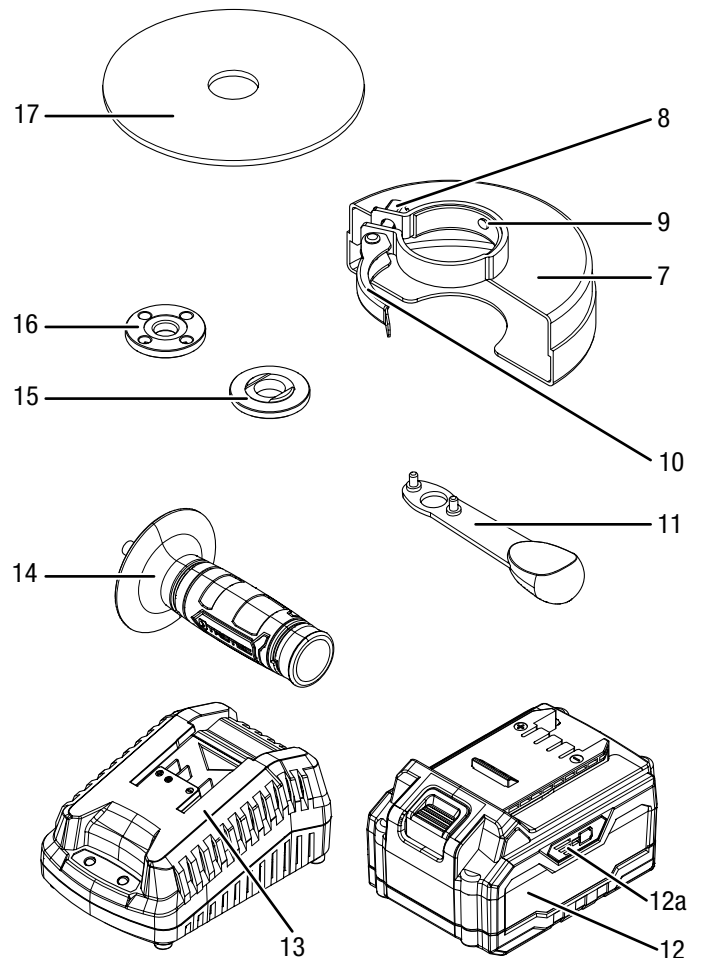
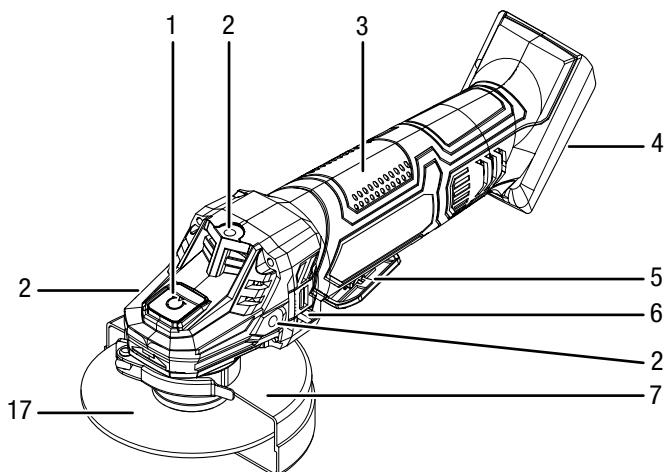

No.	Designation
1	Spindle lock
2	Thread (3 x) for additional handle
3	Device handle
4	Battery holder
5	On/off switch with start lock
6	Venting slots
7	Guard
8	Adjusting screw
9	Coded projection
10	Locking lever
11	Face spanner
12	Battery
12a	Battery level indication
13	Quick charger
14	Additional handle
15	Mounting flange
16	Clamping nut
17	Cutting disc

Scope of delivery

- 1 x Cordless angle grinder PAGS 20-115
- 1 x Rechargeable battery
- 1 x Quick charger
- 1 x Cutting disc for metal, cutting disc diameter: 115 mm
- 1 x Guard
- 1 x Additional handle
- 1 x Face spanner
- 1 x Clamping nut
- 1 x Transport case
- 1 x Manual

Technical data

Parameter	Value
Model	PAGS 20-115
Nominal voltage	20 V ---
Rated speed	10,000 rpm
Spindle thread	M14
Maximum disc diameter	115 mm
Weight	2.55 kg
Cutting disc (scope of delivery)	
Idle speed cutting disc	13,300 rpm
Disc speed	80 m/s
Bore diameter	22.23 mm
Cutting disc thickness	3 mm
Battery	PAGS 20-115 DC
Type	Li-ion
Nominal voltage	20 V ---
Capacity	4.0 Ah
Quick charger	PAGS 20-115 AC
Input	
Nominal voltage	230 – 240 V / 50 Hz
Power input	94 kW
Output	
Nominal voltage	21.5 V ---
Charging current	3.5 A
Charging time	1.5 h
Cable length	1.5 m
Protection class	II / \square
Vibration information according to EN 60745	
Vibration emission value main handle a_h	2.6 m/s ²
Vibration emission value additional handle a_h	1.7 m/s ²
Uncertainty K main handle / additional handle	1.5 m/s ²
Sound values according to EN 60745	
Sound pressure level L_{pA}	81 dB(A)
Sound power L_{WA}	92 dB(A)
Uncertainty K	3 dB

**Wear hearing protection.**

Excessive noise can lead to hearing loss.

Information on noise and vibration:

- The vibration level specified in these instructions was determined by means of a measuring method standardized in EN 60745 and can be used for a device comparison. The specified vibration emission value may also be used for a preliminary assessment of the exposure.

**Caution**

Vibration emissions can cause a health hazard if the device is used for an extended period of time or if it is not properly handled and maintained.

- The vibration level will change depending on the application of the power tool and may in some cases differ from the value specified in these instructions. The vibration load may be underestimated if the power tool is used regularly in such a way. For a precise estimation of the vibration load during a certain work period, it is also important to consider the periods during which the device is switched off, or is running but not actually employed. This can reduce the vibration load over the entire work period significantly.

Transport and storage**Note**

If you store or transport the device improperly, the device may be damaged.

Note the information regarding transport and storage of the device.

Transport

For transporting the device, use the transport case included in the scope of delivery in order to protect the device from external influences.

Before transporting the device, observe the following:

- Switch off the device.
- Hold onto the mains plug while pulling the power cable of the charger out of the mains socket.
- Allow the device to cool down.
- Remove the battery from the device.
- Remove the tool from the tool holder.

The supplied Li-ion batteries are subjects to the requirements of dangerous goods legislation.

Observe the following when transporting or shipping Li-ion batteries:

- The user may transport the batteries by road without any additional requirements.
- If transport is carried out by third parties (e.g. air transport or forwarding company), special requirements as to packaging and labelling must be observed. This includes consulting a dangerous goods specialist when preparing the package.
 - Only ship batteries if their housing is undamaged.
 - Mask open terminals with tape and pack the battery in a way that it cannot move inside the packaging.
 - Please also observe any other national regulations.

Storage

Before storing the device, observe the following:

- Switch off the device.
- Hold onto the mains plug while pulling the power cable of the charger out of the mains socket.
- Allow the device to cool down.
- Remove the battery from the device.
- Remove the tool from the tool holder.
- Clean the device as described in the Maintenance chapter.
- For storing the device, use the transport case included in the scope of delivery in order to protect the device from external influences.
- Do not store Li-ion batteries which are completely discharged. Storing discharged batteries can lead to a deep discharge and thus damage the battery.

When the device is not being used, observe the following storage conditions:

- dry and protected from frost and heat
- ambient temperature below 40 °C
- protected from dust and direct sunlight inside the transport case

Start-up

Unpacking the device

- Take the transport case out of the packaging.



Warning of electrical voltage

Electric shock from insufficient insulation.

Check the device for damages and proper functioning before each use.

If you notice damages, no longer use the device.

Do not use the device when the device or your hands are damp or wet!

- Check the contents of the transport case for completeness and look for damages.



Warning

Risk of suffocation!

Do not leave the packaging lying around. Children may use it as a dangerous toy.

- Dispose of the packaging material according to the national regulations.

Charging the battery

Note

The battery can be damaged in case of improper charging.

Remove the charger's mains plug before inserting or removing the battery.

Never charge the battery at ambient temperatures below 10 °C or above 40 °C.

The battery is partially charged upon delivery to avoid damage to the battery caused by a deep discharge.

Prior to initial start-up and when the battery is low (only the red LED in the battery level indication (12a) is illuminated), the battery should be charged. To do so, please proceed as follows:

1. Insert the battery (12) into the quick charger (13) upside down.

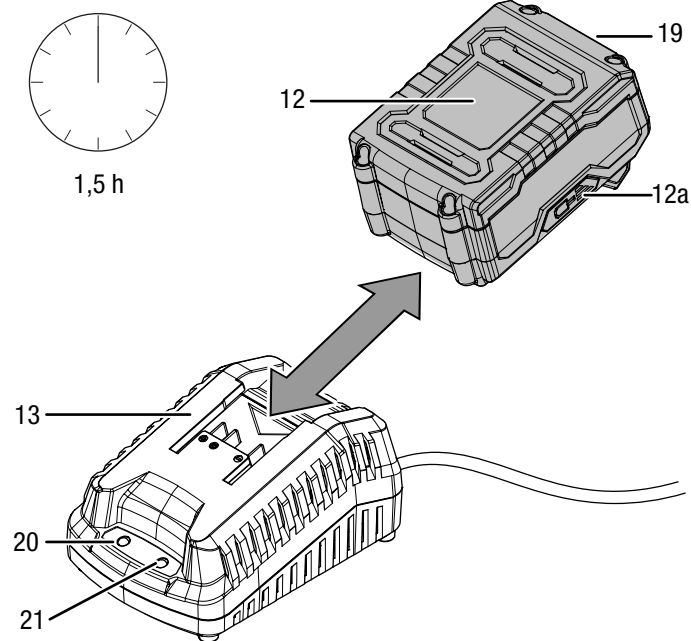

Inserting the battery

1. Slide the battery (12) onto the device until it locks in place.

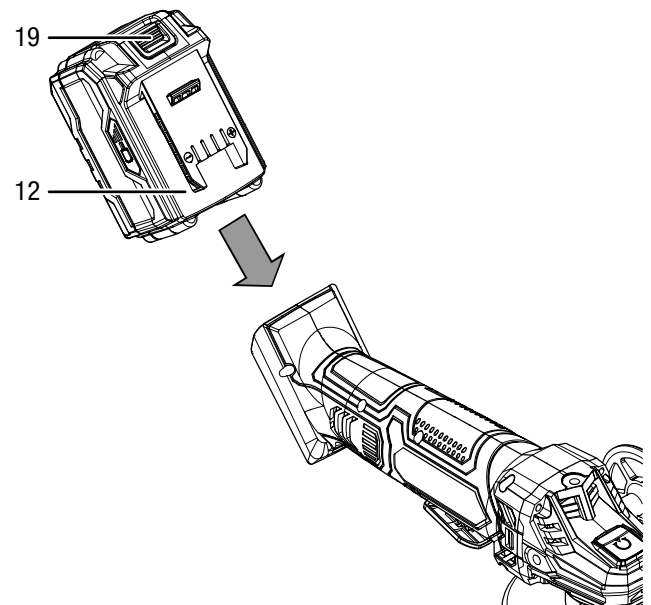

Removing the battery

1. Detach the battery (12) from the device by pressing and holding the release button (19) and pulling the battery off the device.

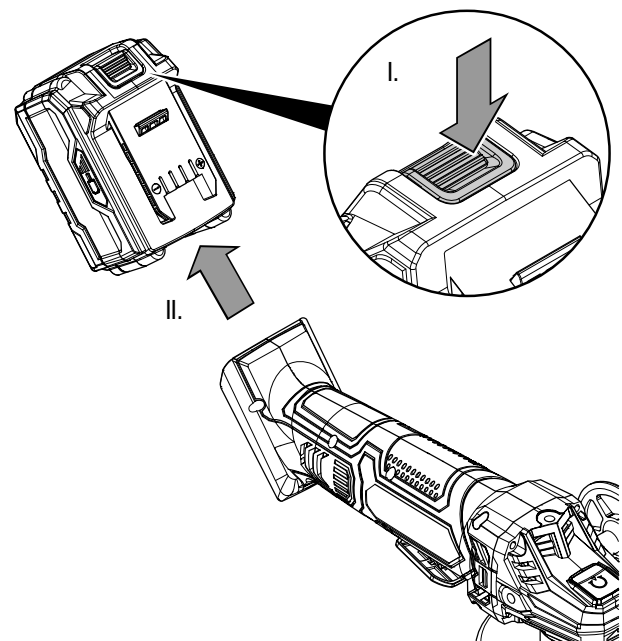

2. If required, charge the battery (12) as described in the section *Charging the battery*.

Checking the battery status

The battery comes with an integrated battery level indication. The battery status is displayed as follows by the three LEDs of the battery level indication (12a):

LED colour	Meaning
Green – Orange – Red	maximum charge / power
Orange – Red	medium charge / power
Red	weak charge – Recharge the battery.

1. Press on the battery icon (22) on the battery (12).
⇒ You can read the battery status from the battery level indication (12a).

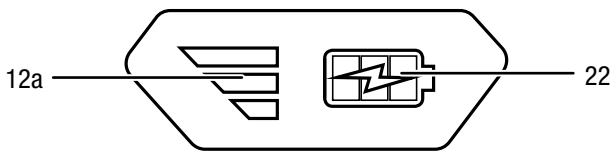

Mounting the handle

Caution Only use the device with the supplied additional handle.

The additional handle (14) must be mounted before start-up. To do so, please proceed as follows:

1. Screw the additional handle (14) clockwise into the thread (2) either on the right or left side or on top of the housing.

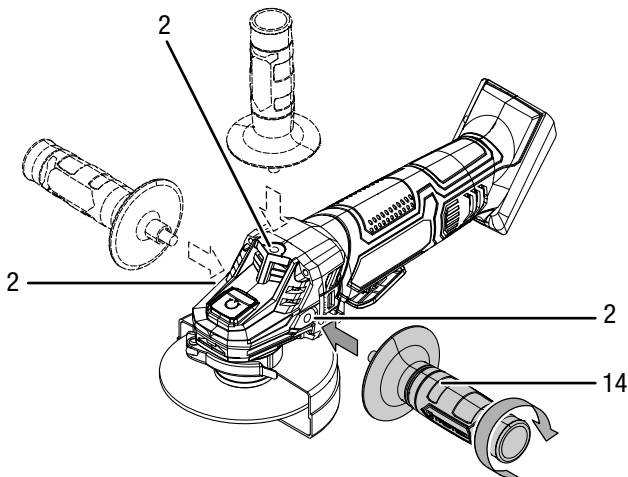

2. Check the additional handle (14) for tight fit.
3. For disassembly unscrew the additional handle (14) counter-clockwise.

Adjusting the guard

Warning of electrical voltage Before any work on the device, remove the mains plug from the mains socket and the battery from the device! Hold onto the mains plug while pulling the power cable out of the mains socket.

Caution If you detect damage at the guard, stop using the device.

The guard is preassembled.

Only use the cordless angle grinder with the guard mounted to protect yourself and your environment from flying sparks, detached parts and accidental contact with the cutting disc.

The guard must be adjusted in a way that sparks cannot ignite combustible parts, including those present in the surroundings.

The guard must be adjusted in a way that flying sparks and detached parts cannot hit the user.

To adjust the guard (7), please proceed as follows:

1. Open the locking lever (10).

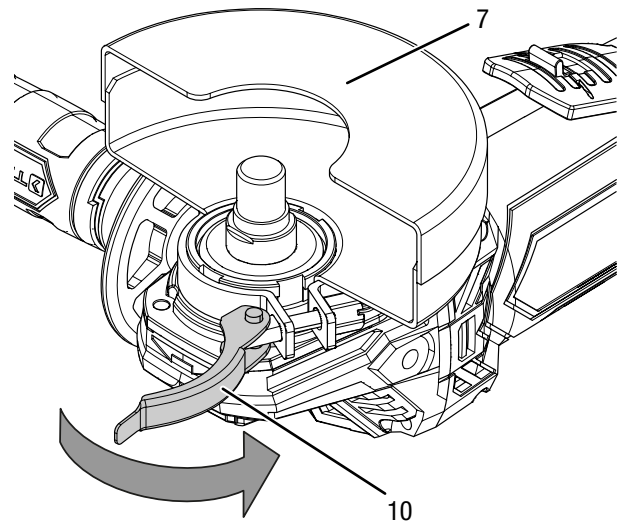

2. Turn the guard (7) into the working position. Make sure that the open side of the guard points towards the workpiece. The closed side of the guard must always point to the user.

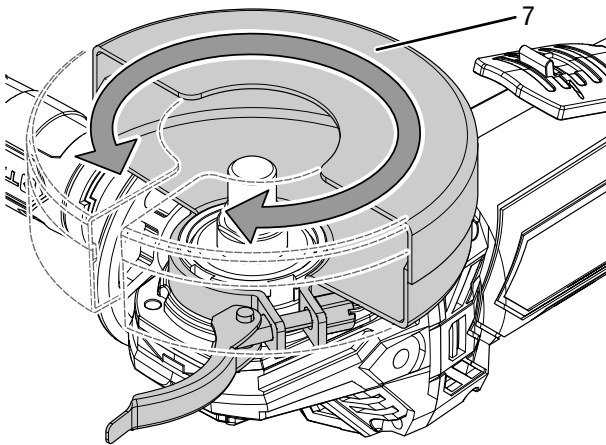

3. Close the locking lever (10).

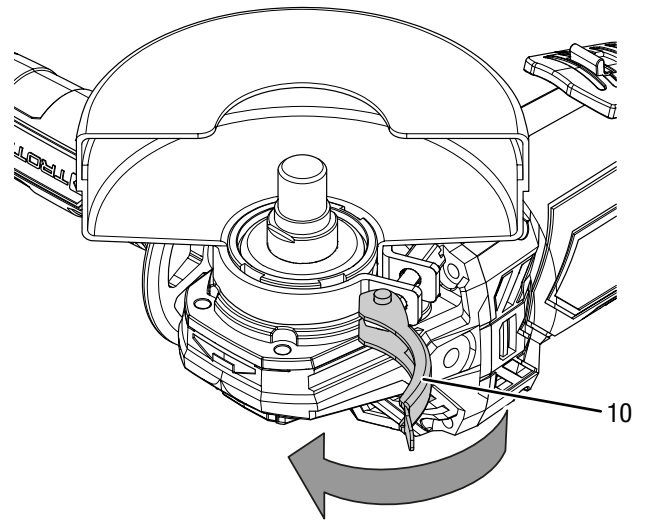

4. Check whether the guard (7) is properly locked in place. It must be impossible to rotate the guard. You can increase the clamping force of the lock by tightening the adjusting screw (8).

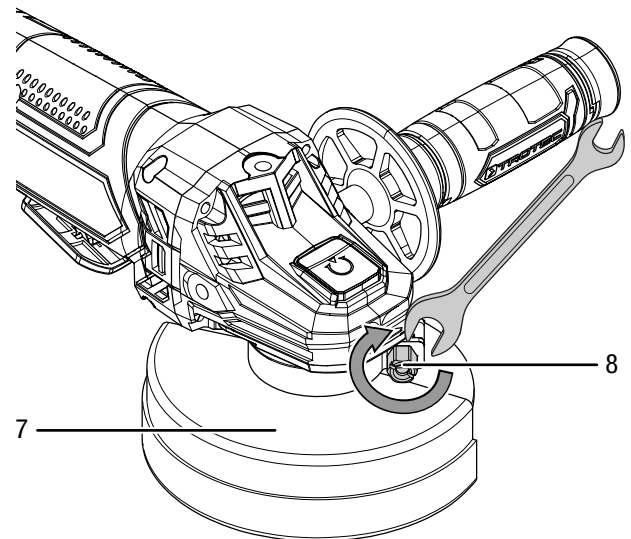
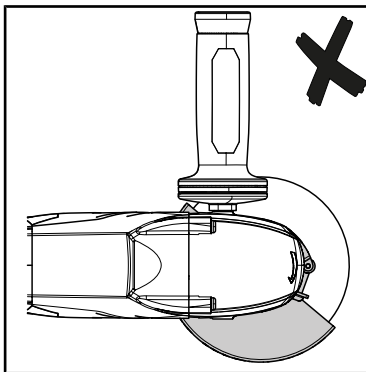
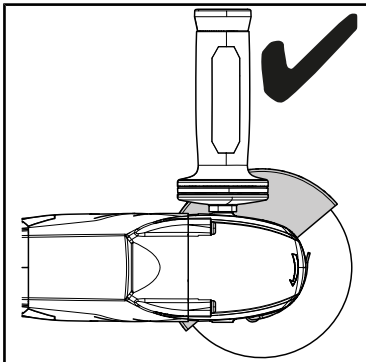

Tool change

The cutting disc for metal is preassembled.



Warning of electrical voltage

Before any work on the device, remove the mains plug from the mains socket and the battery from the device! Hold onto the mains plug while pulling the power cable out of the mains socket.



Warning of hot surface

The insertion tool might still be hot after the application. Burn hazard when touching the insertion tool.



Do not touch the insertion tool bare-handed!
Wear protective gloves!

To change the cutting disc, please proceed as follows:

✓ The spindle is at a standstill and the cutting disc is no longer rotating.

1. Remove the battery from the device.
2. Remove the face spanner (11) from the additional handle (14).

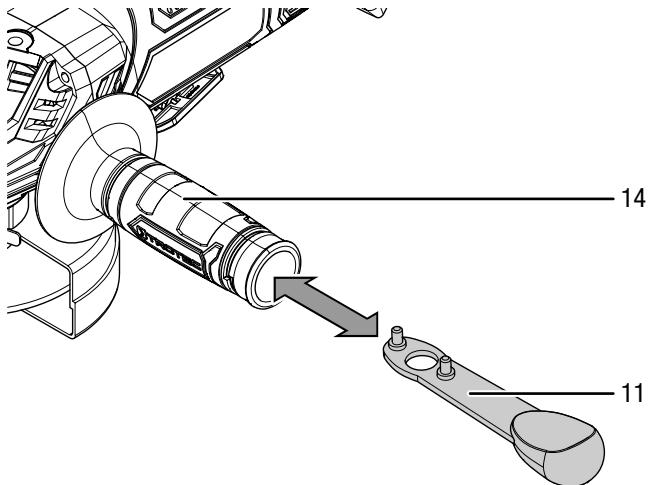

3. Press the spindle lock (1) to block the gears.
4. Slowly turn the clamping nut (16) to the locking point until the lock is fixed. Press and hold the spindle lock (1).

5. Use the face spanner (11) to unscrew the clamping nut (16) counter-clockwise. Then let go of the spindle lock (1).

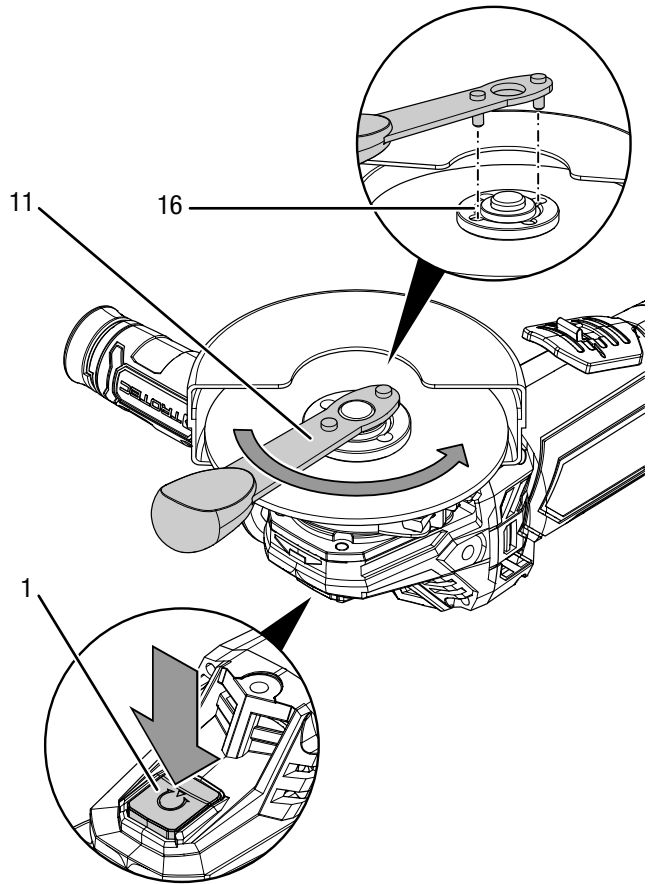

6. Remove the used cutting disc (17). Make sure that the mounting flange (15) is firmly locked in place in the designated recesses.

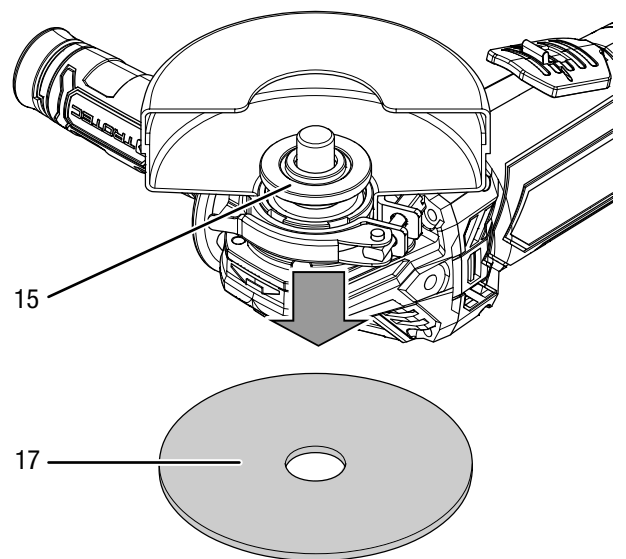

7. Put the cutting disc (17) on the mounting flange (15). The labelling must point to the device. Make sure that the cutting disc hole fits the mounting flange without clearance. Do not use any reducers or adapters.

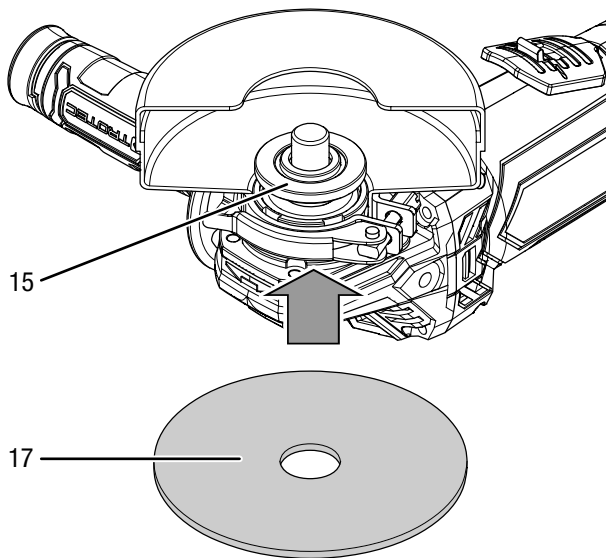

8. Screw the clamping nut (16) back on. The flat side of the clamping nut must point to the device.

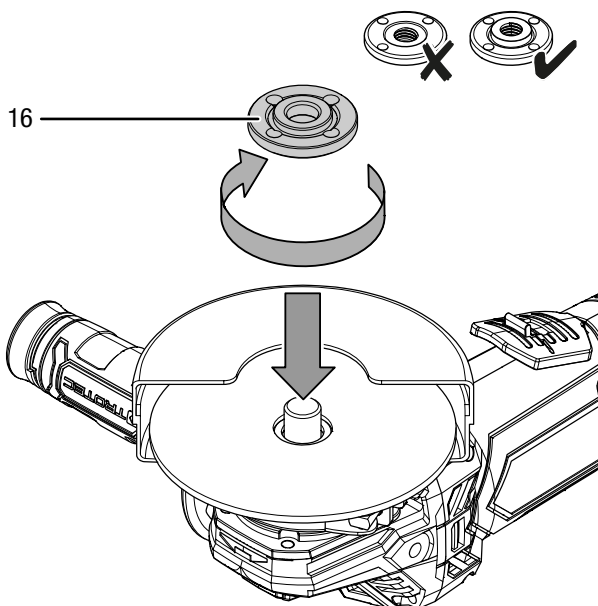

9. Press the spindle lock (1) to lock the gears.
 10. Slowly turn the clamping nut (16) to the locking point until the lock is fixed. Press and hold the spindle lock (1).
 11. Retighten the clamping nut (16) by means of the face spanner (11). Then let go of the spindle lock (1). Pay attention not to damage the cutting disc.

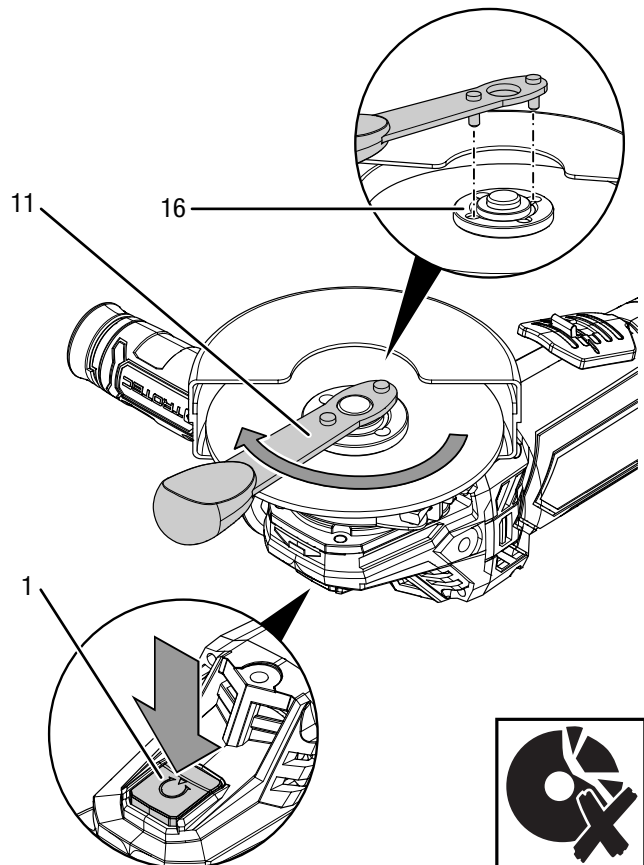

12. Check the cutting disc (17) for proper fit.
 13. Check whether the cutting disc can rotate freely. Make sure that the disc does not touch the guard or other parts.
 14. Carry out a test run of approx. 1 minute without load prior to every disc change and every start-up in order to check the cutting disc for correct fit.
 15. Put the face spanner (11) back into the additional handle (14) for storage.
 16. Put the battery back in.



Caution

If the disc is out-of-round, rotates unevenly, vibrates, oscillates, or if unusual noises or sparks are generated, the cutting disc must be exchanged immediately. Otherwise, there is a risk of injury.

Operation

Tips and notes on handling the cordless angle grinder

General information:

- Carry out a test run of approx. 1 minute without load prior to every disc change and every start-up in order to check the cutting disc for correct fit.
- Only use tools which are approved for the device used.
- Before every application, make sure that you have selected the correct tool for the intended use.
- Check the tool in the tool holder for proper fit before every application. The tool must be firmly locked in place in the designated holding fixtures on the tool holder.
- Check whether the cutting disc can rotate freely. Make sure that the disc does not touch the guard or other parts.
- Only use discs with a speed imprinted that is at least as high as the speed indicated on the device's nameplate.
- Clamp the workpiece unless it is firmly and safely positioned by its own weight.
- Do not overload the device so that it comes to a standstill.
- After operation at high load, let the device run at idle for several minutes to allow the tool to cool down.
- Do not touch the discs until they have cooled down.
- Keep the venting slots clear to prevent the motor from overheating.

Cutting:

- Only use intact, flawless cutting discs. Bent, blunt or otherwise damaged cutting discs could break.
- Never use the cutting disc for roughing!
- Only advance moderately during operation and make sure that the cutting disc does not get jammed.
- Do not slow down the decelerating cutting disc by pressing against the side of the disc.
- Always move the cutting disc through the workpiece in reverse rotation.

Switching the device on and off

Wear your personal protective equipment when working with the device.

1. Check whether the mounted cutting disc is suitable for the intended application.
2. Check whether the workpiece is secured and the worktop prepared correspondingly.
3. Slide back the start lock (18) at the on/off switch (5).
4. Press the on/off switch (5) and hold it during operation.

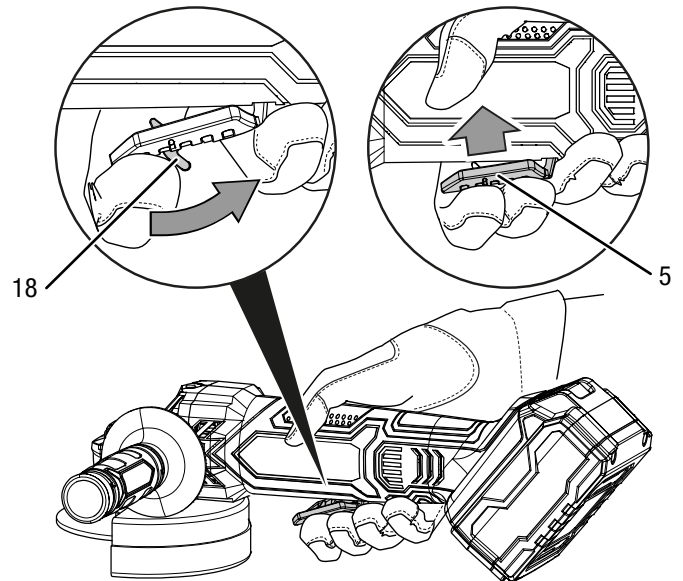

5. Carry out a test run of approx. 1 minute without load prior to every disc change and every start-up in order to check the cutting disc for correct fit.
6. After switch-on, wait until the device has reached its maximum speed. Only then start working.

7. To switch the device off, let go of the on/off switch (5).



Caution

The disc keeps running after the device has been switched off.
Risk of injury.

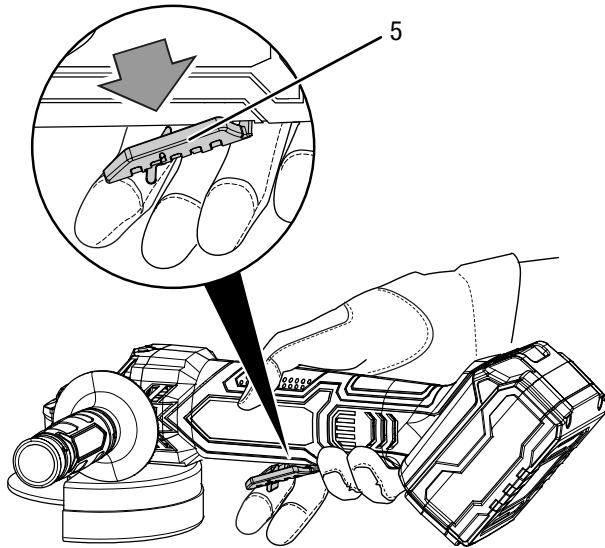

Shutdown



Warning of electrical voltage

Do not touch the mains plug with wet or damp hands.

- Switch off the device.
- Hold onto the mains plug while pulling the power cable of the charger out of the mains socket.
- If required, allow the device to cool down.
- Remove the battery from the device (see Start-up chapter).
- Remove the tool from the device (see Start-up chapter).
- Clean the device according to the Maintenance chapter.
- Store the device according to the Storage chapter.

Available accessories



Warning

Only use accessories and additional equipment specified in the operating manual.
Using insertion tools or accessories other than those specified in the operating manual may cause a risk of injury.

Designation	Article number
Set of diamond cutting discs Ø 110 mm / 115 mm	6.225.001.121
Spare battery Multiflex 4.0 Ah 20V	6.200.000.320

Errors and faults

The device has been checked for proper functioning several times during production. If malfunctions occur nonetheless, check the device according to the following list.

Troubleshooting tasks which require the housing to be opened must only be carried out by an authorized specialist electrical company or by Trotec.

Slight smoke or odour are emitted during first use:

- This is not a fault. These phenomena disappear after a brief runtime.

The battery does not charge:

- Check whether the battery is correctly connected to the quick charger.
Slide the battery into the quick charger in a way that the battery terminals engage in the quick charger. The battery must lock in place in the quick charger.
- Check the power connection.
- Check the power cable and mains plug for damages.
- Check the fuse (home).
- Check the quick charger for damages. Should the quick charger be damaged, stop using it. Contact the Trotec customer service.
- Check the battery terminals for dirt. Remove any dirt.
- The battery might be defective and have to be replaced. Only use batteries of the same type.

The device does not start:

- The battery power might be too low. Recharge the battery.
- Check whether the battery is correctly connected to the device.
Slide the battery onto the device in a way that the battery terminals engage. The battery must lock in place in the device.
- Check the battery terminals for dirt. Remove any dirt.



Info

Wait for at least 10 minutes before switching the device back on.

The cutting disc is loose:

- Check whether you are using a cutting disc that is suited for this device.
- Make sure that the mounting flange is firmly locked in place in the designated recesses.
- Make sure that the cutting disc sits flush on the mounting flange without clearance.
- Make sure that the flat side of the clamping nut rests on the cutting disc.

The guard is loose:

- Make sure that the coded projections are firmly locked in place in the designated groove.
- Make sure that the locking lever is folded in completely.
- If necessary, tighten the adjusting screw.

The cutting disc does not move although the motor is running:

- Make sure that the clamping nut is firmly tightened, see chapter Tool change.
- Make sure that there is no workpiece debris blocking the drive. Remove the blockages, if any.
- Make sure that the cutting disc is not jammed in the workpiece.

The motor slows down:

- Check whether the device is overloaded by the workpiece.
- Reduce the pressure applied on the workpiece.
- Check whether the workpiece is suitable for the tasks to be carried out.

The cutting disc experiences difficulties penetrating the material to be processed or the cutting performance is insufficient:

- Check whether the chosen cutting disc is suitable for the material to be processed.
- If the cutting disc is worn, replace it with a new one.

The device becomes hot:

- Check whether the cutting disc is suitable for the tasks to be carried out.
- Make sure not to exert too much pressure on the device during operation.
- Keep the venting slots clear to prevent the motor from overheating.
- Wait for 10 minutes before switching the device back on.

Note

Wait for at least 3 minutes after maintenance and repair work. Only then switch the device back on.

Your device still does not operate correctly after these checks?

Please contact the customer service. If necessary, bring the device to an authorized specialist electrical company or to Trotec for repair.

Maintenance**Activities required before starting maintenance****Warning of electrical voltage**

Do not touch the mains plug or the battery with wet or damp hands.

- Switch off the device.
- Allow the device to cool down completely.
- Remove the battery from the device.

**Warning of electrical voltage**

Maintenance tasks which require the housing to be opened must only be carried out by authorised specialist companies or by Trotec.

Notes on maintenance

Inside the device, there are no parts that need to be maintained or lubricated by the user.

Cleaning

The device should be cleaned before and after each use.

Note

The device does not have to be lubricated after cleaning.

**Warning of electrical voltage**

There is a risk of a short-circuit due to liquids penetrating the housing!

Do not immerse the device and the accessories in water. Make sure that no water or other liquids can enter the housing.

- Clean the device with a soft, damp and lint-free cloth. Ensure that no moisture enters the housing. Protect electrical components from moisture. Do not use any aggressive cleaning agents such as cleaning sprays, solvents, alcohol-based or abrasive cleaners to dampen the cloth.
- Dry the device with a soft, lint-free cloth.
- Remove dust from inside the guard, from the mounting flange and from the clamping nut.
- Keep the connecting terminals on the device and charger clean.
- Keep the connecting terminals on the battery pack clean.
- Keep the ventilation openings free from dust deposits to prevent overheating of the motor.
- For maintenance of the cutting disc, see chapter Tool change.

Disposal



The icon with the crossed-out waste bin on waste electrical or electronic equipment stipulates that this equipment must not be disposed of with the household waste at the end of its life. You will find collection points for free return of waste electrical and electronic equipment in your vicinity. The addresses can be obtained from your municipality or local administration. For further return options provided by us please refer to our website www.trotec24.com.

The separate collection of waste electrical and electronic equipment aims to enable the re-use, recycling and other forms of recovery of waste equipment as well as to prevent negative effects for the environment and human health caused by the disposal of hazardous substances potentially contained in the equipment.



In the European Union, batteries and accumulators must not be treated as domestic waste, but must be disposed of professionally in accordance with Directive 2006/66/EC of the European Parliament and of the Council of 6 September 2006 on batteries and accumulators. Please dispose of batteries and accumulators according to the relevant legal requirements.

Declaration of conformity

The text below sets out the contents of the declaration of conformity. The signed declaration of conformity can be found at <https://hub.trotec.com/?id=41427>.

Declaration of conformity

In accordance with the EC Machinery Directive 2006/42/EC, Annex II, part 1, Section A

Herewith, we – Trotec GmbH & Co. KG – declare that the machinery designated below was developed, constructed and produced in compliance with the requirements of the EC Machinery Directive in the version 2006/42/EC.

Product model / Product: PAGS 20-115

Product type: cordless angle grinder

Year of manufacture as of: 2018

Relevant EU directives:

- 2011/65/EU: 1 July 2011
- 2014/30/EU: 29 March 2014

Applied harmonised standards:

- EN ISO 12100:2010
- EN 55014-1:2006/A2:2011
- EN 55014-2:2015
- EN 60745-1:2009 + A11:2010
- EN 60745-2-3:2011/A13:2015
- EN 61000-3-2:2014
- EN 61000-3-3:2013

Applied national standards and technical specifications:

- None

Manufacturer and name of the authorised representative of the technical documentation:

Trotec GmbH & Co. KG
Grebbeener Straße 7, D-52525 Heinsberg
Phone: +49 2452 962-400
E-mail: info@trotec.de

Place and date of issue:

Heinsberg, 22.02.2018

Detlef von der Lieck, Managing Director

Trotec GmbH & Co. KG

Grebener Str. 7
D-52525 Heinsberg

☎ +49 2452 962-400

☎ +49 2452 962-200

✉ info@trotec.com

www.trotec.com