

BP21

EN

INSTRUCTIONS
PYROMETER



 **TROTEC**

Table of contents

Information on the use of these instructions 2

Safety 2

Information about the device 4

Transport and storage 7

Operation 7

Maintenance and repair 10

Errors and faults 10

Disposal 11

Information on the use of these instructions

Symbols

 **Warning of electrical voltage**
This symbol indicates dangers to the life and health of persons due to electrical voltage.

 **Warning of laser radiation**
This symbol indicates dangers to the health of persons due to laser radiation.

 **Warning**
This signal word indicates a hazard with an average risk level which, if not avoided, can result in serious injury or death.

 **Caution**
This signal word indicates a hazard with a low risk level which, if not avoided, can result in minor or moderate injury.

Notice
This signal word indicates important information (e.g. material damage), but does not indicate hazards.

 **Info**
Information marked with this symbol helps you to carry out your tasks quickly and safely.

 **Follow the manual**
Information marked with this symbol indicates that the instructions must be observed.

You can download the current version of the instructions and the EU declaration of conformity via the following link:



BP21



<https://hub.trotec.com/?id=44511>

Safety

Read this manual carefully before starting or using the device. Always store the manual in the immediate vicinity of the device or its site of use.

-  **Warning**
Read all safety warnings and all instructions. Failure to follow the warnings and instructions may result in electric shock, fire and/or serious injury.
Save all warnings and instructions for future reference.
- Do not use the device in potentially explosive rooms or areas and do not install it there.
 - Do not use the device in aggressive atmosphere.
 - Do not immerse the device in water. Do not allow liquids to penetrate into the device.
 - The device may only be used in dry surroundings and must not be used in the rain or at a relative humidity exceeding the operating conditions.
 - Protect the device from permanent direct sunlight.
 - Do not expose the device to strong vibrations.
 - Do not open the device.
 - Do not remove any safety signs, stickers or labels from the device. Keep all safety signs, stickers and labels in legible condition.
 - Avoid looking directly into the laser beam.
 - Never point the laser beam at people or animals.
 - Never charge batteries that cannot be recharged.
 - Different types of batteries and new and used batteries must not be used together.
 - Insert the batteries into the battery compartment according to the correct polarity.
 - Remove discharged batteries. Batteries contain materials hazardous to the environment. Dispose of the batteries according to the national regulations.
 - Remove the batteries from the device if you will not be using the device for a longer period of time.

- Never short-circuit the supply terminal in the battery compartment!
- Do not swallow batteries! If a battery is swallowed, it can cause severe internal burns within 2 hours! These burns can lead to death!
- If you think batteries might have been swallowed or otherwise entered the body, seek medical attention immediately!
- Keep new and used batteries and an open battery compartment away from children.
- Observe the storage and operating conditions (see Technical data).

Intended use

This device is exclusively intended for measuring temperature by means of an infrared sensor in the measuring range specified in the technical data. People who use this device must have read and understood the operating manual, especially the Safety chapter.

Any use other than the intended use is regarded as misuse.

Reasonably foreseeable misuse

The device must not be pointed at people. Do not use the device in potentially explosive atmospheres, for measurements in liquids or at live parts. Any unauthorised modifications, alterations or structural changes to the device are forbidden.

Personnel qualification

People who use this device must:

- be aware of the dangers that occur when working with laser measuring devices.
- have read and understood the instructions, especially the Safety chapter.

Safety signs and labels on the device

Notice

Do not remove any safety signs, stickers or labels from the device. Keep all safety signs, stickers and labels in legible condition.

The following safety signs and labels are attached to the device:

Warning sign	
Meaning	<p>The warning sign is located on the back of the device and indicates that the device is equipped with a class 2 laser.</p> <p>The power is less than 1.0 mW. The frequency range of the laser is 630 to 670 nm.</p> <p>Do not look directly into the laser beam or the opening from which the laser beam emerges!</p>

Residual risks



Warning of electrical voltage

There is a risk of a short-circuit due to liquids penetrating the housing!

Do not immerse the device and the accessories in water. Make sure that no water or other liquids can enter the housing.



Warning of electrical voltage

Work on the electrical components must only be carried out by an authorised specialist company!



Warning of laser radiation

Laser class 2, P max.: <math>< 1\text{ mW}</math>, λ : 400-700 nm, EN 60825-1:2014

Do not look directly into the laser beam or the opening from which it emerges.

Never point the laser beam at people, animals or reflective surfaces. Even brief eye contact can lead to eye damage.

Examining the laser output aperture by use of optical instruments (e.g. magnifying glass, magnifiers and the like) entails the risk of eye damage.

When working with a laser of class 2, observe the national regulations on wearing eye protection.



Warning

Risk of suffocation!

Do not leave the packaging lying around. Children may use it as a dangerous toy.



Warning

The device is not a toy and does not belong in the hands of children.



Warning

Dangers can occur at the device when it is used by untrained people in an unprofessional or improper way! Observe the personnel qualifications!



Caution

Keep a sufficient distance from heat sources.

Notice

To prevent damages to the device, do not expose it to extreme temperatures, extreme humidity or moisture.

Notice

Do not use abrasive cleaners or solvents to clean the device.

Information about the device

Device description

The pyrometer BP21 uses an infrared sensor to measure surface temperatures without contact. An integrated dual laser pointer can be switched on for the precise determination of the measuring spot diameter.

You can set the emissivity of the material to be measured so as to achieve a more precise measurement result.

For the temperature measurement the device allows you to set freely definable thresholds. Exceeding or falling below these preselected thresholds is indicated by an acoustic alarm function.

In addition, the device indicates either the highest or lowest value of the measurement.

The display can be illuminated as needed. When not in use, an automatic switch-off saves the battery.

Measuring principle

The device measures the temperature by means of an infrared sensor. Important factors playing a role in the temperature measurement are the measuring spot diameter and the emissivity.

Measuring spot

Observe the distance to measuring spot diameter ratio. The larger the distance to the object, the larger the measuring spot diameter and hence, the less precise the measured result, for the device calculates an average temperature from all the temperatures in the measuring spot.

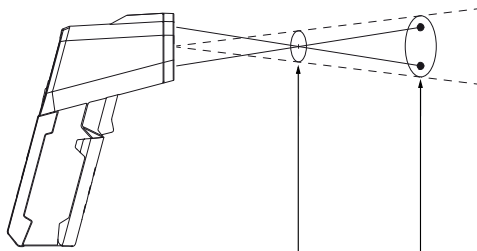

Spot	12.5 mm	100 mm
Distance	150 mm	1200 mm
	D:S = 12:1	
—————	Laser	
- - - - -	Infrared	

Emissivity

Emissivity is a value used to describe the energy radiation characteristics of a material.

Most organic materials have an emissivity of 0.95. Metals or shiny materials come with a much lower value.

A material's emissivity depends on various factors, e.g. on

- Material composition
- Surface condition
- Temperature

The emissivity can range between 0.1 and 1 (in theory).

The following rule of thumb can be assumed:

- When a material is rather dark and its surface texture matt, it probably has a high emissivity.
- The brighter and smoother the surface of a material, the lower will be its emissivity, presumably.
- The higher the emissivity of the surface to be measured, the better it is suited for non-contact temperature measurement by use of a pyrometer or thermal imaging camera, since falsifying temperature reflections become negligible.

Nevertheless, entering an emissivity as appropriate as possible is indispensable for a precise measurement.

Emissivity table

The table below may be used as reference for setting the emissivity. It supplies reference values for the emissivity of common materials.

Material	Emissivity
Aluminium, roughened	0.1 to 0.3
Aluminium, alloy A3003, oxidized	0.3
Aluminium, oxidized	0.2 to 0.4
Asbestos	0.92 to 0.95
Tarmac	0.92 to 0.95
Basalt	0.7
Concrete	0.92 to 0.95
Bitumen	0.98 to 1.00
Lead, oxidized	0.2 to 0.6
Lead, rough	0.4
Roofing felt	0.95
Ice	0.98
Iron (forged), blunt	0.9
Iron, oxidized	0.5 to 0.9
Iron, rusted	0.5 to 0.7
Enamel varnish, black	0.95
Earth	0.92 to 0.96
Paint (not alkaline)	0.90 to 0.95
Paint (non-metal)	0.95
gypsum	0.60 to 0.95
Glass, pane	0.85 to 0.95
Rubber	0.92 to 0.95
Cast iron, molten	0.2 to 0.3
Cast iron, not oxidized	0.2
Skin	0.98
Haynes alloy	0.3 to 0.8
Radiator enamel	0.95
Timber (natural)	0.90 to 0.95
Inconel, electro-polished	0.15
Inconel, oxidized	0.70 to 0.95
Inconel, sand-blasted	0.3 to 0.6
Limestone	0.95 to 0.98
Carborundum	0.9
Ceramics	0.88 to 0.95
Gravel	0.95
Carbon, graphite	0.70 to 0.85
Carbon, not oxidized	0.8 to 0.9

Material	Emissivity
Plastic, non-transparent	0.95
Copper, oxidized	0.4 to 0.8
Varnish	0.80 to 0.95
Marble	0.90 to 0.95
Brass, highly polished	0.3
Brass, oxidized	0.5
Molybdenum, oxidized	0.2 to 0.6
Nickel, oxidized	0.2 to 0.5
Paper (any colour)	0.9
Plastic	0.85 to 0.95
Plaster	0.90 to 0.95
Sand	0.9
Snow	0.9
Steel, heavy plate	0.4 to 0.6
Steel, cold-rolled	0.7 to 0.9
Steel, oxidized	0.7 to 0.9
Steel, polished sheet metal	0.1
Steel, stainless	0.1 to 0.8
Cloth	0.95
Wallpaper (non-metal)	0.95
Textiles (non-metal)	0.95
Titanium, oxidized	0.5 to 0.6
Clay	0.90 to 0.95
Water	0.93
Cement	0.90 to 0.96
Brick (rough)	0.90 to 0.95
Zinc, oxidized	0.1

Device depiction

Device depiction

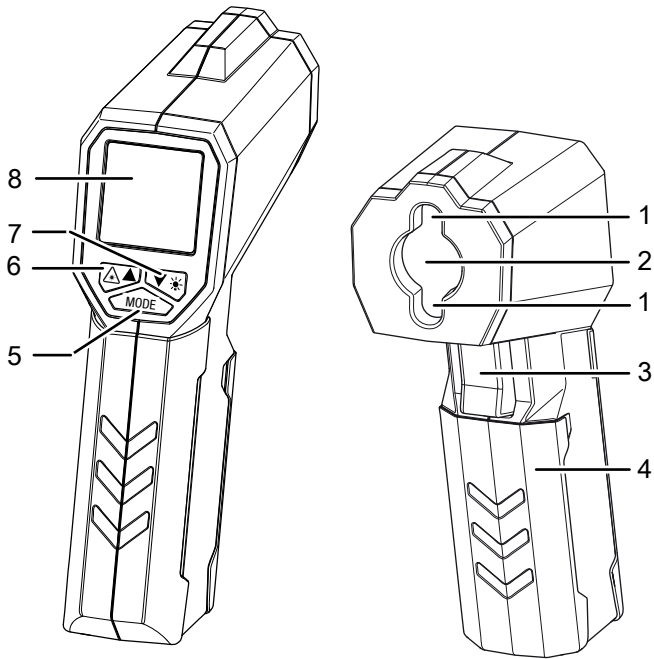

No.	Designation
1	Dual laser pointer
2	Infrared sensor
3	Measurement button
4	Battery compartment with cover
5	MODE button
6	Laser/Up button
7	Light/Down button
8	Display

Display

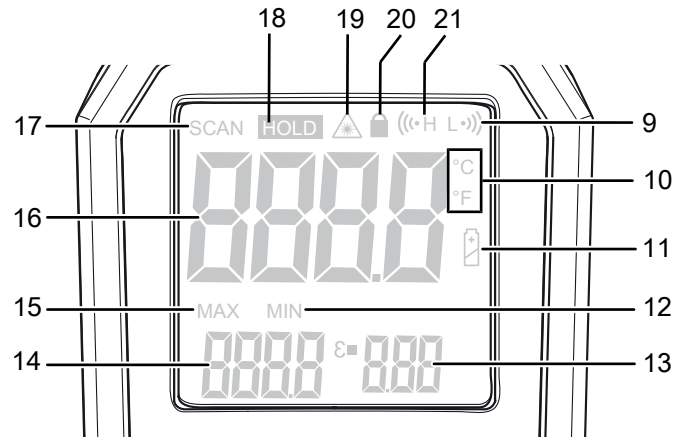

No.	Designation
9	Lower alarm threshold indication
10	Temperature unit indication
11	Battery status indication
12	MIN indication
13	Emissivity indication
14	MAX/MIN temperature indication
15	MAX indication
16	Measurement value display
17	SCAN indication
18	HOLD indication
19	Laser indication
20	Continuous measurement indication
21	Upper alarm threshold indication

Technical data

Parameter	Value
Model	BP21
Weight	177 g
Dimensions (H x W x L)	108 mm x 45 mm x 150 mm
Measuring range	-35°C to 800°C (-31°F to 1472°F)
Measuring range resolution	0.1 °C / °F
Laser output	< 1 mW (630–670 nm)
Laser	Class II, 630 to 670 nm, < 1 mW
Accuracy	± 2 °C (±4 °F) or ± 2.0 % of the measured value (the higher value applies)
Emissivity	Adjustable
Distance to measuring spot diameter ratio	12:1
Smallest measuring spot	∅ 12.5 mm (distance 150 mm)
Spectral sensitivity	8 to 14 µm
Reaction time	< 1 s
Operating temperature	0°C to 50°C (32°F to 122°F)
Relative humidity during operation	Max. 80 % relative humidity
Storage conditions	-20 °C to 60 °C
Power supply	9 V battery
Switch-off	After approx. 8 seconds of non-use

Scope of delivery

- 1 x Pyrometer BP21
- 1 x Device bag
- 1 x Quick guide

Transport and storage

Notice

If you store or transport the device improperly, the device may be damaged.

Note the information regarding transport and storage of the device.

Transport

For transporting the device, use the bag included in the scope of delivery in order to protect the device from external influences.

Storage

When the device is not being used, observe the following storage conditions:

- dry and protected from frost and heat
- protected from dust and direct sunlight
- with a cover to protect it from invasive dust if necessary
- the storage temperature complies with the values specified in the Technical data
- Batteries are removed from the device

Operation

Inserting the battery

Notice

Make sure that the surface of the device is dry and the device is switched off.

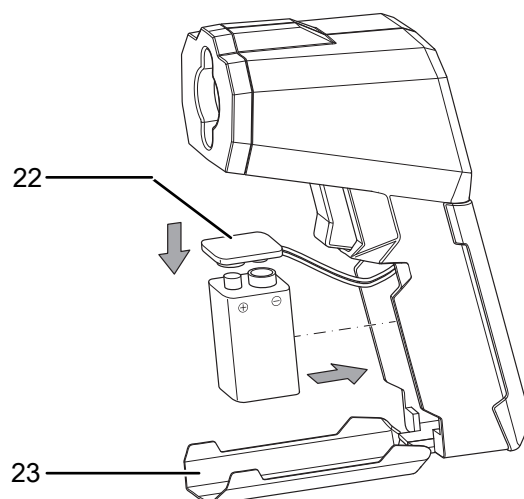

1. Open the battery compartment by sliding open the battery compartment cover (23).
2. Use the battery clip (22) to connect the new battery with correct polarity.
3. Insert the battery in the battery compartment.
4. Close the cover of the battery compartment.

Switching the device on

1. Briefly press the *Measurement* button (3).
⇒ The device switches on.

Notice

In measuring mode, the device switches off automatically after 10 seconds if it has been inactive and no button has been actuated during this time.

Carrying out a measurement



Info

Please note that moving from a cold area to a warm area can lead to condensation forming on the device's circuit board. This physical and unavoidable effect can falsify the measurement. In this case, the display shows either no measured values or they are incorrect. Wait a few minutes until the device has become adjusted to the changed conditions before carrying out a measurement.

- Ensure that the surface to be measured is free of dust, dirt or similar substances.
- To be able to gain exact measurement results on surfaces which reflect heavily, stick matt masking tape to the surface or apply matt black paint with a very high and known emissivity.
- Note the 12:1 ratio of the distance to the measuring spot size. For accurate measurements the measuring object should be at least twice as large as the measuring spot.

Please proceed as follows to carry out a measurement:

1. Point the device at the object to be measured.
2. Press the *Measurement* button (3).
⇒ Hold onto the *Measurement* button if you want to perform a prolonged measurement.
⇒ The device turns on and carries out a measurement. The *SCAN* indication (17) appears on the display.
⇒ The currently measured value is displayed on the measurement value display (16).
3. Let go of the *Measurement* button.
⇒ The device stops measuring. The *HOLD* indication (18) appears on the display.

Switching the laser pointer on or off

Ex works the laser pointer is switched off.



Danger

Please note that when the laser is switched on, the laser pointer will light up as soon as you press the *Measurement* button (3) or activate continuous measurement.



Warning of laser radiation

Class 2 laser radiation.

Lasers of class 2 only radiate in the visible range and during continuous wave operation (lasting beam) no more than 1 milliwatt (mW) of output will be emitted. Looking directly into the laser beam for a longer period of time (more than 0.25 seconds) can cause damage to the retina.

Avoid looking directly into the laser beam. Never look into the laser beam using optical aides. Do not suppress the winking reflex when looking into the laser beam unintentionally. Never point the laser beam at people or animals.

1. Press the *Laser/Up* button (6).
⇒ The *Laser* indication (19) appears on the display.
⇒ The laser pointer is switched on.
2. Press the *Laser/Up* button again to switch the laser pointer off.
⇒ The *Laser* indication is no longer displayed.
⇒ The laser pointer is switched off, memorising the selected settings.

Switching the display illumination on or off

Ex works the display illumination is switched off. Proceed as follows to operate the display illumination:

1. Switch the device on.
2. Press the *Light/Down* button (7) to switch on the display illumination.
3. Press the *Light/Down* button (7) again to switch off the display illumination.

The device memorizes the selected setting when switching off.

Further setting options

You can use the *MODE* button (5) to set advanced functions on the device. Each time you press the *MODE* button, the device switches to the next function. The functions are arranged as follows:

Position	Function
1	Setting the emissivity
2	Setting the temperature unit
3	Activating/deactivating maximum/minimum value
4	Activating/deactivating continuous measurements
5	Activating/deactivating the upper alarm threshold
6	Setting upper alarm value
7	Activating/deactivating the lower alarm threshold
8	Setting lower alarm value

Examples:

- If you have just set the temperature unit and now would like to change the upper alarm value, press the *MODE* button (5) four times.
- If you have just activated the lower alarm value and now would like to set the emissivity, press the *MODE* button (5) twice.

Setting the emissivity

1. Press the *MODE* button (5) repeatedly until you reach the desired function.
 - ⇒ The *Emissivity* indication (13) appears on the display.
2. Set the emissivity by increasing or decreasing the value using the *Laser/Up* (6) and *Light/Down* (7) buttons.
 - ⇒ The value range is between 1.00 and 0.10.
3. Press the *Measurement* button (3) to confirm the selected settings and return to the measuring mode.

Setting the temperature unit

1. Press the *MODE* button (5) repeatedly until you reach the desired function.
2. Set the temperature unit using the *Laser/Up* (6) and *Light/Down* (7) buttons.
 - ⇒ The measured value can be displayed in °C or °F.
 - ⇒ The selected unit appears on the display in the *Temperature unit indication* (10).
3. Press the *Measurement* button (3) to confirm the selected settings and return to the measuring mode.

Activating/deactivating maximum/minimum value

1. Press the *MODE* button (5) repeatedly until you reach the desired function.
2. Use the *Laser/Up* (6) and *Light/Down* (7) buttons to select whether the MAX or MIN temperature value is to be displayed.
 - ⇒ If the MAX temperature value is selected, *MAX* (15) appears on the display and the highest temperature value measured is indicated in the *MAX/MIN temperature* indication (14).
 - ⇒ If the MIN temperature value is selected, *MIN* (12) appears on the display and the lowest temperature value measured is indicated in the *MAX/MIN temperature* indication (14).
3. Press the *Measurement* button (3) to confirm the selected settings and return to the measuring mode.

Activating continuous measurement

Notice

Once the continuous measurement function is activated, the measurement will continue until the function is terminated again. The settings for the display illumination and laser cannot be changed during this period. Therefore, select the corresponding settings before activating continuous measurement.

1. Press the *MODE* button (5) repeatedly until you reach the desired function.
 - ⇒ The *continuous measurement* indication appears on the display (20). It is deactivated by default (*OFF*).
2. Use the *Laser/Up* (6) and *Light/Down* (7) buttons to select the *ON* mode and press the *Measurement* button (3) to start the continuous measurement.
 - ⇒ The current measured value is indicated on the measurement value display (16).
 - ⇒ During continuous measurement, you can adjust the emissivity to changing grounds. Set the emissivity by increasing or decreasing the value using the *Laser/Up* (6) and *Light/Down* (7) buttons.
3. Briefly press the *Measurement* button (3) to terminate the continuous measurement.

Upper alarm threshold

Activating/deactivating the upper alarm threshold

1. Press the *MODE* button (5) repeatedly until you reach the desired function.
2. Use the *Laser/Up* (6) and *Light/Down* (7) buttons to select whether the upper alarm threshold is to be activated or deactivated.
 - ⇒ If the upper alarm threshold is activated, *Upper alarm threshold* (21) is indicated on the display.
 - ⇒ If the upper alarm threshold is exceeded during a measurement, an acoustic signal will be emitted.
3. Press the *Measurement* button (3) to confirm the selected settings and return to the measuring mode.

Setting upper alarm value

1. Press the *MODE* button (5) repeatedly until you reach the desired function.
2. Set the value of the upper alarm threshold using the *Laser/Up* (6) and *Light/Down* (7) buttons.
3. Press the *Measurement* button (3) to confirm the selected settings and return to the measuring mode.

Lower alarm threshold

Activating/deactivating the lower alarm threshold

1. Press the *MODE* button (5) repeatedly until you reach the desired function.
2. Use the *Laser/Up* (6) and *Light/Down* (7) buttons to select whether the lower alarm threshold is to be activated or deactivated.
 - ⇒ If the lower alarm threshold is activated, *Lower alarm threshold* (9) is indicated on the display.
 - ⇒ If a measured value falls below the lower alarm threshold during a measurement, an acoustic signal will be emitted.
3. Press the *Measurement* button (3) to confirm the selected settings and return to the measuring mode.

Setting lower alarm value

1. Press the *MODE* button (5) repeatedly until you reach the desired function.
2. Set the value of the lower alarm threshold using the *Laser/Up* (6) and *Light/Down* (7) buttons.
3. Press the *Measurement* button (3) to confirm the selected settings and return to the measuring mode.

Switching the device off

The device comes with an automatic switch-off function:

- The device switches off automatically after 10 seconds if it has been inactive and no button has been actuated during this time.
- The automatic switch-off function does not respond during continuous measurement.

Maintenance and repair

Battery change

It is required to change the battery when the *Battery status indication* (11) lights up on the display (8) of the device or when the device can no longer be switched on (see Operation chapter).

Cleaning

Clean the device with a soft, damp and lint-free cloth. Make sure that no moisture enters the housing. Do not use any sprays, solvents, alcohol-based cleaning agents or abrasive cleaners, but only clean water to moisten the cloth.

Repair

Do not modify the device or install any spare parts. For repairs or device testing, contact the manufacturer.

Errors and faults

The device has been checked for proper functioning several times during production.

In the event of malfunctions, for repairs or device testing, contact the manufacturer.

Disposal

Always dispose of packing materials in an environmentally friendly manner and in accordance with the applicable local disposal regulations.



The icon with the crossed-out waste bin on waste electrical or electronic equipment is taken from Directive 2012/19/EU. It states that this device must not be disposed of with the household waste at the end of its life. You will find collection points for free return of waste electrical and electronic equipment in your vicinity. The addresses can be obtained from your municipality or local administration. You can also find out about other return options that apply for many EU countries on the website <https://hub.trotec.com/?id=45090>. Otherwise, please contact an official recycling centre for electronic and electrical equipment authorised for your country.

The separate collection of waste electrical and electronic equipment aims to enable the re-use, recycling and other forms of recovery of waste equipment as well as to prevent negative effects for the environment and human health caused by the disposal of hazardous substances potentially contained in the equipment.



In the European Union, batteries and accumulators must not be treated as domestic waste, but must be disposed of professionally in accordance with Directive 2006/66/EC of the European Parliament and of the Council of 6 September 2006 on batteries and accumulators. Please dispose of batteries and accumulators according to the relevant legal requirements.

Only for United Kingdom

According to Waste Electrical and Electronic Equipment Regulations 2013 (SI 2013/3113) (as amended) and the Waste Batteries and Accumulators Regulations 2009 (SI 2009/890) (as amended), devices that are no longer usable must be collected separately and disposed of in an environmentally friendly manner.

Trotec GmbH

Grebener Str. 7
D-52525 Heinsberg

☎ +49 2452 962-400

☎ +49 2452 962-200

✉ info@trotec.com

www.trotec.com