

EN

INSTRUCTIONS
OZONE METER



Table of contents

Information on the use of these instructions 2

Safety 2

Information about the device 4

Transport and storage 7

Operation 7

Maintenance and repair 11





Errors and faults 12

Disposal 13

Warranty 13

Information on the use of these instructions

Symbols

-  **Warning**
This signal word indicates a hazard with an average risk level which, if not avoided, can result in serious injury or death.
-  **Warning of electrical voltage**
This symbol indicates dangers to the life and health of persons due to electrical voltage.
-  **Caution**
This signal word indicates a hazard with a low risk level which, if not avoided, can result in minor or moderate injury.
- Notice**
This signal word indicates important information (e.g. material damage), but does not indicate hazards.
-  **Info**
Information marked with this symbol helps you to carry out your tasks quickly and safely.
-  **Follow the manual**
Information marked with this symbol indicates that the instructions must be observed.

You can download the current version of these instructions via the following link:



OZ-ONE



<https://hub.trotec.com/?id=41860>

Safety

Read this manual carefully before starting or using the device. Always store the manual in the immediate vicinity of the device or its site of use.



Warning

Read all safety warnings and all instructions.

Failure to follow the warnings and instructions may result in electric shock, fire and/or serious injury.

Save all warnings and instructions for future reference.

- Do not use the device in potentially explosive rooms or areas and do not install it there.
- Do not use the device in an aggressive atmosphere.
- Protect the device from permanent direct sunlight.
- Do not open the device.
- Do not remove any safety signs, stickers or labels from the device. Keep all safety signs, stickers and labels in legible condition.
- Use batteries of type AAA.
- Never charge batteries that cannot be recharged.
- Different types of batteries and new and used batteries must not be used together.
- Insert the batteries into the battery compartment according to the correct polarity.
- Remove discharged batteries. Batteries contain materials hazardous to the environment. Dispose of the batteries according to the national regulations.
- Remove the batteries from the device if you will not be using the device for a longer period of time.
- Never short-circuit the terminals of batteries!
- Do not swallow batteries! If a battery is swallowed, it can cause severe internal burns within 2 hours! These burns can lead to death!
- If you think batteries might have been swallowed or otherwise entered the body, seek medical attention immediately!
- Keep new and used batteries and an open battery compartment away from children.
- Observe the storage and operating conditions (see Technical data).

Intended use

Only use the device for measurements of the ozone concentration in the air as well as for indoor temperature and humidity measurements within the measuring range specified in the technical data.

Any use other than the intended use is regarded as misuse.

Reasonably foreseeable misuse

Do not use the device in potentially explosive atmospheres, for measurements in liquids or at live parts.

Any unauthorised modifications, alterations or structural changes to the device are forbidden.

Do not utilise the device for measuring ozone concentrations outside the measuring range specified, for instance after the use of ozone generators. Permanent or repeated exposure of the device to an ozone concentration that is too high for the sensor may damage the sensor! Observe the specifications regarding the measuring range in the technical data.

Personnel qualification

People who use this device must:

- have read and understood the instructions, especially the Safety chapter.

Residual risks



Warning

There is a danger of suffocation for children due to packaging material! Keep packaging films and parts away from children. There is a risk of death due to suffocation.



Warning of electrical voltage

There is a risk of a short-circuit due to liquids penetrating the housing!
Do not immerse the device and the accessories in water. Make sure that no water or other liquids can enter the housing.



Warning of electrical voltage

Work on the electrical components must only be carried out by an authorised specialist company!



Warning

The device is not a toy and does not belong in the hands of children.



Warning

Dangers can occur at the device when it is used by untrained people in an unprofessional or improper way!
Observe the personnel qualifications!



Caution

Keep a sufficient distance from heat sources.

Notice

Never expose the sensor to hard shocks. Do not shake the sensor, e.g. to ventilate the sensor chamber after an oversaturation, since the reaction electrolyte in the sensor can be irreparably damaged.

Notice

Do not blow into the sensor ball and do not actively warm it in your hand, e.g. by encompassing it, because temperature, changing humidity as well as air currents can influence and falsify the measurement result. Moreover, if the humidity level has been rapidly increased all of a sudden, interruptions of the sensor output can occur ("rEg", see chapter Errors and faults).

Notice

To prevent damages to the device, do not expose it to extreme temperatures, extreme humidity or moisture.

Notice

Do not use abrasive cleaners or solvents to clean the device.

Information about the device

Device description

The device OZ-ONE is an ozone meter for measuring the ozone concentration in the air. It can also be used to determine the air, dew point and wet-bulb temperature as well as the humidity level of indoor areas.

For assessing the measurements, a Max/Min function (maximum and minimum value), the time-weighted average, the short-term exposure limit and a Hold function for freezing the currently measured value are also available.

When not in use, an automatic switch-off saves the batteries.

Formation, perception and distribution of ozone

The word ozone has become an integral part of our vocabulary and the colourless, toxic gas is part of our everyday life. The irritant effect ozone can have on our eyes and airways has been common knowledge for a few years now, especially since the increasing ozone volume can be attributed to the so-called summer smog. Ozone is further generated during certain industrial processes.

Ozone (chemical symbol: O₃) consists of three oxygen atoms. Ozone is created wherever oxygen molecules (O₂) in the air are turned into atoms (O) due to electrical energy or UV radiation. It is these atoms that can react with the oxygen molecules to form ozone (O₃).

In case of a high solar irradiation ozone forms involving other air pollutants. The nitrogen oxides (NO_x) from automobiles, domestic heating systems, power plants and the industry play a major role in this.

Depending on the concentration, ozone can have a very intense smell similar to chlorine, hay or carnations, odours that can be smelled in mountain areas. By nature, the human nose is already vastly superior to most measuring devices: It detects the gas with a concentration of as little as 0.01 ml/m³. What this means when compared to other irritant gases is that we humans can already detect even minor quantities of ozone which gives us the opportunity to take corresponding precautions to avoid any hazard caused by the gas in due time. However, our nose also has a crucial disadvantage compared with measuring devices: the so-called *habituation effect*. After only a brief period of time spent in an ozone-polluted environment we become so acclimated to the smell that we go noseblind.

The impact of ozone on human beings

The sensitivity to ozone depends on its concentration and varies for each individual. Ozone is an oxidative irritant gas, affecting eyes, nose, pharynx and lungs even at low concentrations. The mucous membranes are unable to stop it seeing as ozone is hardly soluble in water. As a result, the gas can be carried deeper into the lungs than other irritant gases. Concentrations of 200 µg/mm³ and higher can cause the following symptoms:

- irritations of the mucous membranes, eyes and the respiratory tract
- hoarseness, coughs and headaches
- feeling of constriction behind the sternum
- reduced physical performance

The main damage is caused in the respiratory tract which can lead to breathing difficulties and a reduced respiratory volume. Late complications can include nosebleeds, a bronchitis (or tracheitis) or a pulmonary oedema. But the transition from irritations without lasting consequences to long-term changes with pathological significance is very smooth.

Device depiction

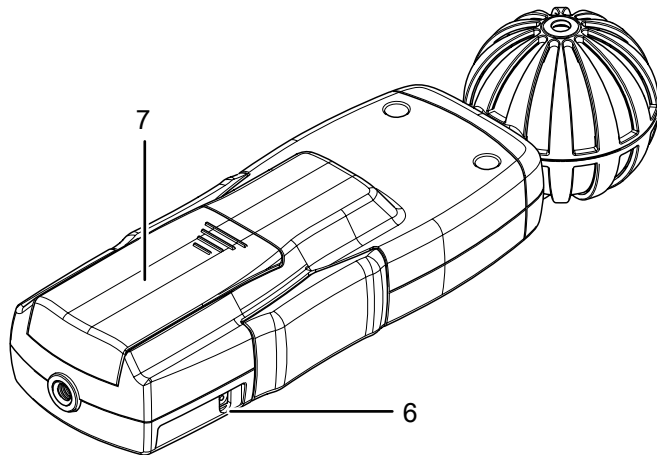
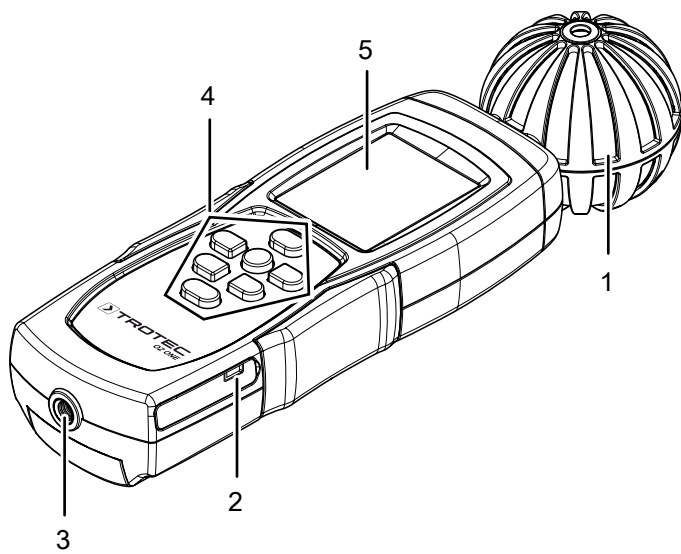

No.	Designation
1	Measuring probe with protective cap
2	Mini USB port
3	Tripod thread
4	Operating elements
5	Display
6	Connector for the power adapter
7	Battery compartment with cover

Operating elements

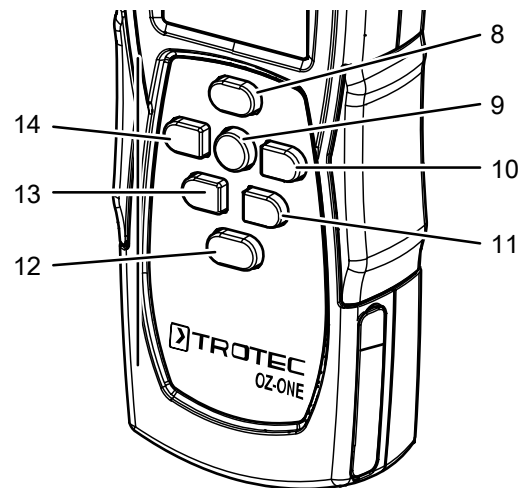

No.	Designation
8	<i>HOLD</i> button
9	<i>Power</i> button
10	<i>MAX/MIN</i> button
11	<i>UNIT</i> button
12	<i>Light</i> button
13	<i>SET</i> button
14	<i>MODE</i> button

Display

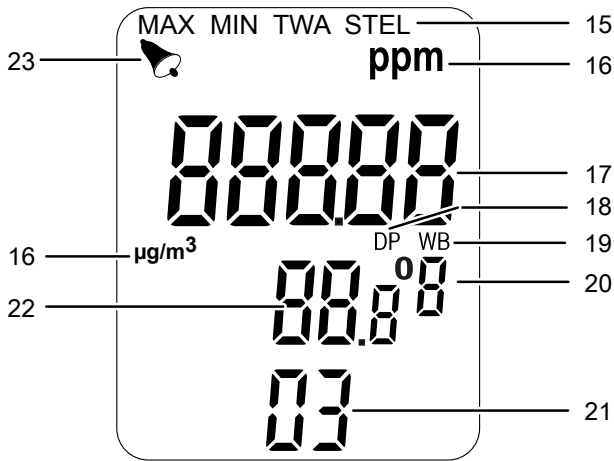

No.	Indication	Meaning
15	Measuring mode	Indication of different measuring modes: MAX = highest ozone concentration of the measurement interval MIN = lowest ozone concentration of the measurement interval TWA = time-weighted average of the ozone concentration STEL = short-term exposure limit of the ozone concentration
16	Ozone concentration unit	Indication of the selected unit: - ppm - µg/m ³
17	Measured ozone concentration	Current or held ozone concentration value
18	Dew point temperature	Dew point temperature is displayed in (22)
19	Wet-bulb temperature	Wet-bulb temperature is displayed in (22)
20	Temperature/humidity unit	Unit of the measured value displayed in (22)
21	Ozone measuring mode	Indication of the current process: O3 = ozone concentration measurement in progress Hold = measured values are held SEt = setting open SAVE = prompt for saving the setting CAL = calibration in progress
22	Measured value multi	Indication of various measured values: - ambient temperature - relative humidity level - dew point temperature - wet-bulb temperature
23	Alarm	Alarm for exceeding the set ozone limit is switched on

Technical data

Parameter	Value
Model	OZ-ONE
Article number	3.510.006.110
Weight	185 g
Dimensions (length x width x height)	210 mm x 60 mm x 40 mm
Power supply	4 AAA batteries
Automatic switch-off	after approx. 15 minutes
Ozone concentration	
Measuring principle	Electrochemical sensor
Measuring range	0 to 1,996 µg/m ³ (at 20 °C, 50 % RH and 1,013 hPa)
Accuracy	< 0.1 ppm (< 200 µg/m ³): ±0.02 ppm (±40 µg/m ³) at 25 °C and 1,013 hPa; otherwise ±10 %
Measuring range resolution	1 µg/m ³ or 0.01 ppm (10 ppb)
Drift	±2 % / month*
Relative humidity	
Measuring range	0.0 % RH to 99.9 % RH
Accuracy	± 3 % RH (at 10 % to 70 % and 25 °C) ± 5 % RH (0 % to 10 % and 70 % to 99.9 %)
Measuring range resolution	0.1 %
Reaction time	2 s
Operating conditions	0 °C to 50 °C, < 80 % RH (non-condensing)
Storage conditions	-20 °C to 50 °C, < 90 % RH (non-condensing)
Air temperature	
Measuring range	0 °C to 50 °C or 32 °F to 122 °F
Accuracy	±0.6 °C
Measuring range resolution	0.1 °C
* This systematic measurement deviation is attributable to the characteristics of the required O ₃ sensor technology. Electrochemical sensors are wear products and subject to a continuous aging process from the date of manufacture (see also chapter Errors and faults).	

Scope of delivery

- 1 x Device OZ-ONE
- 1 x Calibration certificate
- 1 x Transport bag
- 1 x Quick guide

Transport and storage

Notice

If you store or transport the device improperly, the device may be damaged.

Note the information regarding transport and storage of the device.

Transport

For transporting the device, use the bag included in the scope of delivery in order to protect the device from external influences.

Storage

When the device is not being used, observe the following storage conditions:

- dry and protected from frost and heat
- protected from dust and direct sunlight
- protected from dust ingress in the supplied bag
- stored in the resealable zip bag it has been supplied in
- at the temperature specified in the technical data
- Batteries are removed from the device

Operation

Inserting the batteries

Notice

Make sure that the surface of the device is dry and the device is switched off.

1. Open the battery compartment (7) by sliding open the cover with your fingers.
2. Remove the battery compartment cover.
3. Insert the batteries (4 batteries of type AAA) into the battery compartment with correct polarity.
4. Slide the cover back onto the battery compartment.

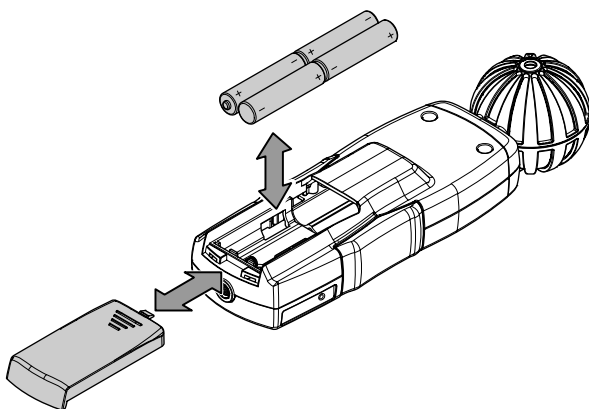

Switch-on and ozone level measurements

Notice

Never expose the sensor to hard shocks. Do not shake the sensor, e.g. to ventilate the sensor chamber after an oversaturation, since the reaction electrolyte in the sensor can be irreparably damaged.

Notice

Do not blow into the sensor ball and do not actively warm it in your hand, e.g. by encompassing it, because temperature, changing humidity as well as air currents can influence and falsify the measurement result. Moreover, if the humidity level has been rapidly increased all of a sudden, interruptions of the sensor output can occur ("rEg", see chapter Errors and faults).

Notice

Note that moving from a cold area to a warm area can lead to condensation forming on the device's circuit board. This physical and unavoidable effect can falsify the measurement. In this case, the display shows either no measured values or they are incorrect. Wait a few minutes until the device has become adjusted to the changed conditions before carrying out a measurement.

Notice

Cross-sensitivities

Due to the construction of the electrochemical sensor, the device also reacts to gases other than ozone. Besides, a high humidity level (e.g. by blowing into the measuring probe) can falsify the result. For this reason, always make sure that no other gases influence the measurement and that the measuring probe is not exposed to sources of high humidity when you measure the ozone concentration.

1. Briefly press the *Power* button (9).
 - ⇒ The display will be activated and the device will be in a warm-up phase for about three minutes.
 - ⇒ At the end of that phase the device is ready for operation and can be used for measurements.
 - ⇒ The device indicates the ozone concentration in the *Measured ozone concentration* indication (17), and the relative humidity and ambient temperature in the *Measured value multi* indication (22).



Info

If no ozone concentration is detected in the current measuring range, the measuring device indicates "0.00" in the *Measured ozone concentration* indication (17).

Switching on the background illumination

1. Briefly press the *Light* button (12).
⇒ The background illumination is activated.
2. Briefly press the *Light* button (12) again to deactivate the background illumination.

Using the HOLD function

Proceed as follows to freeze the measured values on the display:

1. Press the *HOLD* button (8).
⇒ The current values for the ozone concentration, relative humidity level and ambient temperature will be held.
2. Press the *HOLD* button (8) again.
⇒ The display again indicates the current measured values.

Displaying DP and WB values

The ozone concentration is always displayed in the *Measured ozone concentration* indication (17).

Further measured values that can be indicated are the dew point temperature DP and the wet-bulb temperature WB.

The wet-bulb temperature is the lowest air temperature that can be achieved by evaporation cooling. The dew point temperature is the temperature at which the moisture contained in the air reaches 100 % RH and condenses. Both values are influenced by the initial values of air temperature, relative humidity and air pressure.

Please proceed as follows to have these values displayed by the device:

1. Press the *MODE* button (14) once to display the dew point temperature.
⇒ The *Dew point temperature* indication (18) appears.
⇒ The dew point temperature is shown in the *Measured value multi* indication (22).
2. Press the *MODE* button (14) twice to display the wet-bulb temperature.
⇒ The *Wet-bulb temperature* indication (19) appears.
⇒ The wet-bulb temperature is shown in the *Measured value multi* indication (22).

3. Press the *MODE* button (14) again to display the ambient temperature and relative humidity again.

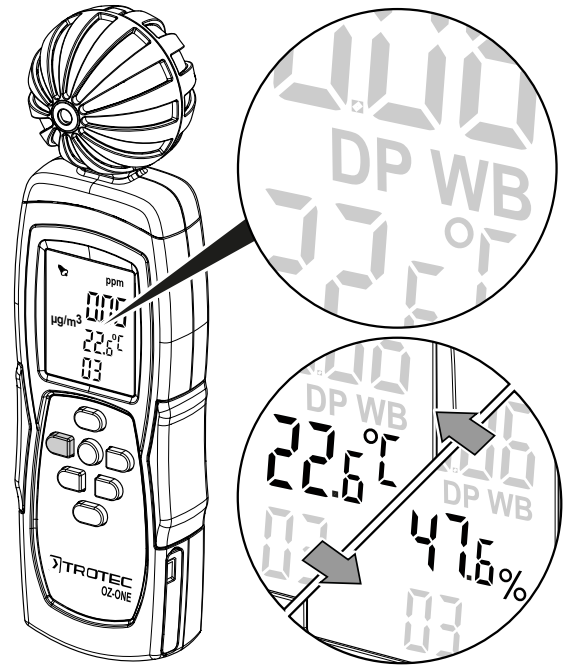

Using the MAX/MIN function

You can view the highest or lowest value for the ozone concentration from the current measuring interval.

To do so, please proceed as follows:

1. Briefly press the *MAX/MIN* button (10).
⇒ The *MAX* indication appears in the *Measuring mode* indication (15).
⇒ The display now indicates the highest ozone concentration measured since the device was switched on in the selected measuring mode.
2. Press the *MAX / MIN* button (10) again.
⇒ The *MIN* indication appears in the *Measuring mode* indication (15).
⇒ The display now indicates the lowest ozone concentration measured since the device was switched on in the selected measuring mode.
3. Press the *MAX/MIN* button (10) a third time to return to the normal measuring mode.
⇒ The display shows the current measured value for the ozone concentration on the indication (17) again.

Resetting the MAX/MIN values

The MAX/MIN values of the current measuring interval can be reset. To do so, please proceed as follows:

- ✓ The MAX/MIN function is activated.
- 1. Press and hold the *HOLD* button (8) for approx. 3 seconds.
 - ⇒ The letters "CLr" appear in the *Ozone measuring mode* indication (21). The MAX/MIN values of the current measuring interval will be reset and the device automatically returns to the normal measuring mode.

Displaying the time-weighted average of the ozone concentration

The time-weighted average TWA indicates the average value of the ozone concentration measured over a period of eight hours. If the device was in operation for less than eight hours, the average value will be calculated based on the time span since the last switch-on.

Please proceed as follows to have the time-weighted average value TWA displayed by the device:

1. Repeatedly press the *MAX/MIN* button (10) until TWA is shown in the *Measuring mode* indication (15).
 - ⇒ The device indicates the time-weighted average TWA for the measured ozone concentration.

Displaying the short-term exposure limit for the ozone concentration

The short-term exposure limit STEL indicates the average ozone concentration over the last 15 minutes. If the device was in operation for less than 15 minutes, the short-term exposure limit STEL will be calculated based on the time span since the last switch-on.

Please proceed as follows to have the short-term exposure limit STEL displayed by the device:

1. Repeatedly press the *MAX/MIN* button (10) until STEL is shown in the *Measuring mode* indication (15).
 - ⇒ The device indicates the short-term exposure limit STEL for the measured ozone concentration.

Changing the ozone concentration unit

The device can display the ozone concentration in either ppm or $\mu\text{g}/\text{m}^3$. Please proceed as follows to switch between the units:

1. Press and hold the *UNIT* button (11) for approx. 3 seconds to change the unit.
 - ⇒ The currently selected unit ppm or $\mu\text{g}/\text{m}^3$ is shown in the *Ozone concentration unit* indication (16).

Changing the unit °C / °F

The default setting for the temperature unit is °C.

Please proceed as follows to change the temperature unit:

1. Press the *UNIT* button (11) to change the unit.
 - ⇒ The currently selected unit °C or °F is shown in the *Temperature/humidity unit* indication (20).

Configuring the alarm for the ozone limit value

The ozone limit alarm has been preconfigured in the factory for a value of 0.06 ppm. If a measurement exceeds this value and the alarm function is activated, an acoustic signal will be emitted.

You can manually configure the ozone limit value from 0.00 ppm to 1.00 ppm.

Please proceed as follows to manually configure the ozone limit value:

1. Press and hold the *SET* button (13) for approx. 3 seconds.
 - ⇒ The letters "SEt" appear in the *Ozone measuring mode* indication (21) and the *Measured ozone concentration* indication (17) flashes.
2. Set the desired value using the *HOLD* (8) and *Light* (12) buttons.
 - ⇒ Press the *HOLD* button (8) to increase the value.
 - ⇒ Press the *Light* button (12) to reduce the value.
3. Use the *MAX/MIN* (10) and *MODE* button (14) to switch between the different positions in the *Measured ozone concentration* indication (17).
 - ⇒ Press the *MAX/MIN* button (10) to move one position to the right.
 - ⇒ Press the *MODE* button (14) to move one position to the left.
4. Press and hold the *SET* button (13) to save the changes.
 - ⇒ The letters "SAVE" appear in the *Ozone measuring mode* indication (21) and the device switches to the air pressure setting screen.

Adjusting the air pressure value

The air pressure has a significant impact on the measured ozone level. In order to achieve better measurement results, you can manually adjust the air pressure value between 300 hPa and 1100 hPa.

Please proceed as follows to set the air pressure value:

1. Press and hold the *SET* button (13) for approx. 3 seconds.
 - ⇒ The letters "SEt" appear in the *Ozone measuring mode* indication (21) and the *Measured ozone concentration* indication (17) flashes.
2. Press and hold the *SET* button (13) again.
 - ⇒ The letters "SAVE" appear in the *Ozone measuring mode* indication (21) and the device switches to the air pressure setting screen.
3. Set the desired value using the *HOLD* (8) and *Light* (12) buttons.
 - ⇒ Press the *HOLD* button (8) to increase the value.
 - ⇒ Press the *Light* button (12) to reduce the value.
4. Use the *MAX/MIN* (10) and *MODE* button (14) to switch between the different positions in the display for the reference air pressure.
 - ⇒ Press the *MAX/MIN* button (10) to move one position to the right.
 - ⇒ Press the *MODE* button (14) to move one position to the left.
5. Press and hold the *SET* button (13) to save the changes.
 - ⇒ The selected air pressure value will be saved and the device automatically returns to the normal measuring mode.

Setting the temperature/ humidity value deviation

The device comes with a maintenance-free precision sensor for air temperature and humidity. When in long-term use or in use for special precision measurements, the sensors for temperature and humidity can be adjusted if the surrounding conditions are known. To do so, please proceed as follows:

- ✓ The device is switched off.
1. Simultaneously press and hold the *MODE* (14) and *Light* (12) buttons as well as the *MAX/MIN* (10) and *Power* (9) buttons.
 - ⇒ The letters "SEt" appear in the *Ozone measuring mode* indication (21) and the *Measured value multi* indication (22) shows "0.0 °C".
 2. Let go of all buttons again.
 3. Press the *UNIT* button (11) to switch between °C and °F.
 4. Set the temperature deviation from the previously displayed temperature. You can set a temperature value deviation of up to ±9.9 °C/ F.
 - ⇒ Press the *HOLD* button (8) to increase the value.
 - ⇒ Press the *Light* button (12) to reduce the value.
 5. Press the *SET* button (13) to exit this mode and to switch to the adjustment options for the relative humidity value.

6. Set the deviation from the previously displayed humidity level. You can set a deviation of up to ±9.9 % RH.
 - ⇒ Press the *HOLD* button (8) to increase the value.
 - ⇒ Press the *Light* button (12) to reduce the value.
7. Press the *SET* button (13) to save the values.
 - ⇒ The letters "SAVE" will appear in the *Ozone measuring mode* indication (21) for approx. 2 seconds.
8. Press and hold the *Power* button (9) for approx. 3 seconds.
 - ⇒ The device will be switched off.
 - ⇒ The set values are saved.

Ozone zero adjustment

To calibrate the device, an ozone zero adjustment can be made in an ozone-free environment. To do so, please proceed as follows:

1. Simultaneously press and hold the *UNIT* (11) and *SET* (13) buttons.
 - ⇒ The letters "CAL" will appear in the *Ozone measuring mode* indication (21).
2. Simultaneously press the *UNIT* (3) button and *SET* (7) button again.
 - ⇒ The calibration is started. The device counts backwards from 120.
 - ⇒ After calibration, the word "End" appears in the *Ozone measuring mode* indication (21) and the device automatically returns to the normal measuring mode.



Info

Ensure to carry out the calibration in surroundings that are free of other gases the sensor reacts to, e.g. nitrogen dioxide. For more detailed information about cross-sensitivities please refer to the chapter *Errors and faults*.

De-/Activating the alarm function for the ozone limit value

Once the ozone limit value has been configured, the alarm function can be activated or deactivated manually.

Please proceed as follows to activate the alarm function.

1. Press the *Power* button (9) for approx. 1 second.
 - ⇒ The *Alarm* indication (23) will be displayed and the alarm function is activated.
2. Press the *Power* button (9) again for approx. 1 second to deactivate the alarm function.
 - ⇒ The *Alarm* indication (23) will no longer be displayed and the alarm function is deactivated.

Automatic switch-off

In default setting, the automatic switch-off function is activated. The device switches off when not in use for 15 minutes.

To deactivate automatic switch-off, please proceed as follows:

- ✓ The device is switched off.
- 1. Simultaneously press the *Power* button (9) and the *HOLD* button (8) until the message "n" is displayed.
 - ⇒ Automatic switch-off is deactivated.
 - ⇒ The device switches to the normal measuring mode.



Info

If you switch off the device manually, the automatic switch-off setting is reset, i.e. automatic switch-off is activated again when the device is switched back on.

Switch-off

1. Press and hold the *Power* button (9) for approx. 3 seconds.
 - ⇒ The device will be switched off.

Maintenance and repair

Battery change

A battery change is required when a battery indication lights up on the display, when the display shows unreliable values, when the display flickers or when the device can no longer be switched on. See chapter Operation.

Cleaning

Clean the device with a soft, damp and lint-free cloth. Make sure that no moisture enters the housing. Do not use any sprays, solvents, alcohol-based cleaning agents or abrasive cleaners, but only clean water to moisten the cloth.

Repair

Do not modify the device or install any spare parts. For repairs or device testing, contact the manufacturer.

Errors and faults

The following error messages can be displayed in the *Measured ozone concentration* indication (17):

Error message	Cause	Remedy
rEg	High measured values - sensor regenerates	Wait until the regeneration phase is over. This process may take up to one minute. Once the device returns to the normal measuring mode, you can proceed with the next measurement. If this is not the case, please contact the customer service.
Er1	Defective sensor	Please contact the customer service.
oL2	Message appears in <i>Measured ozone concentration</i> indication (17): Measured ozone value is outside the device's measuring range.	At first, wait for the measured value to drop and check whether the measurement value display returns back to normal. If this is not the case, please contact the customer service.
	Message appears in measurement value display for humidity (22): Measured humidity value is outside the device's measuring range, temperature is displayed correctly and alternating with the error message.	
	Message appears in measurement value display for temperature (22): Measured temperature value is outside the device's measuring range, humidity is displayed correctly and alternating with the error message.	

Design-related, the electrochemical sensor deployed in the device offers various advantages, e.g.:

- short warm-up phase
- linear response
- good repeatability and accuracy
- fast response time (1–2 seconds)
- low energy intake
- only limited cross-sensitivity to other VOCs

Due to its functional principle, though, one ought to observe the following:

- A high humidity level as well as temperature changes can influence the measurement and may lead to increased measured values.
- Based on the ongoing oxidation the sensor lifetime is limited. We therefore recommend to put the device back into the resealable plastic zip bag it has been delivered in to prevent it from being continuously exposed to the oxygen in the air during storage.

There is a risk of cross-sensitivity to other gases and to combinations of other gases. These include:

- Nitrogen dioxide
- Chlorine
- Hydrogen sulphide
- Sulphur dioxide
- Nitric oxide
- Carbon monoxide
- Carbon dioxide
- Ammonia
- Hydrogen
- Water vapour



Info

The cross-sensitivities are not restricted to this list. In addition, the sensitivity of the sensor changes with the conditions of the tested surroundings (air pressure, humidity level, temperature etc.).

Disposal

Always dispose of packing materials in an environmentally friendly manner and in accordance with the applicable local disposal regulations.



The icon with the crossed-out wheeled bin indicates that this device and any associated components (e.g. remote controls) must not be disposed of with household waste at the end of their life, in accordance with the Waste Electrical and Electronic Equipment Directive (2012/19/EU) and national laws.

You will find collection points for free return of waste electrical and electronic equipment in your vicinity. The addresses can be obtained from your municipality or local administration. You can also find out about other return options that apply for many EU countries on the website <https://hub.trotec.com/?id=45090>. Otherwise, please contact an official recycling centre for electronic and electrical equipment authorised for your country.

The separate collection of waste electrical and electronic equipment aims to enable the re-use, recycling and other forms of recovery of waste equipment as well as to prevent negative effects for the environment and human health caused by the disposal of hazardous substances potentially contained in the equipment.



This icon with the crossed-out wheeled bin indicates that batteries or accumulators must not be disposed of with household waste at the end of their life. If the device contains batteries or accumulators that contain mercury, cadmium or lead, the respective chemical symbol (Hg, Cd or Pb) is shown below the icon of the crossed-out wheeled bin. To prevent environmental pollution, do not carelessly leave batteries or electrical and electronic equipment containing batteries in public areas. In the European Union, batteries and accumulators must be returned to a designated collection point in accordance with REGULATION (EU) 2023/1542 OF THE EUROPEAN PARLIAMENT AND OF THE COUNCIL of 12 July 2023 concerning batteries and waste batteries. Remove batteries/accumulators and dispose of them separately according to the relevant legal requirements.

Only for United Kingdom

According to Waste Electrical and Electronic Equipment Regulations 2013 (SI 2013/3113) (as amended) and the Waste Batteries and Accumulators Regulations 2009 (SI 2009/890) (as amended), devices that are no longer usable must be collected separately and disposed of in an environmentally friendly manner.

Warranty

As a result of its construction and functional principle the integrated O₃ sensor is a wear product.

For the O₃ sensor itself we provide a pan-European one-year warranty from the date of purchase. The guarantee is issued by: Trotec GmbH, Grebbener Straße 7, 52525 Heinsberg.

Statutory warranty rights (liability for defects) shall not be limited by this warranty in any way. The warranty covers any repair and shipment charges in case of defects or damages at the O₃ sensor within the warranty period and not resulting from improper handling. In the case of a warranty claim, please contact Trotec GmbH at the address indicated above.

Trotec GmbH

Grebbener Str. 7
52525 Heinsberg
Germany

☎ +49 2452 962-0

☎ +49 2452 962-200

✉ online@trotec.com

www.trotec.com