

TAC V+ TOWER / TAC M TOWER

EN

ORIGINAL INSTRUCTIONS
HIGH-PERFORMANCE AIR
PURIFIER



Table of contents

Notes regarding the instructions 2

Safety 2

Information about the device 4

Transport and storage 5

Assembly and installation 6

Operation 7

Available accessories 14

Errors and faults 15

Maintenance 16

Technical annex 21

Disposal 34

Declaration of conformity 34

Notes regarding the instructions

Symbols

 **Warning of electrical voltage**
This symbol indicates dangers to the life and health of persons due to electrical voltage.

 **Warning**
This signal word indicates a hazard with an average risk level which, if not avoided, can result in serious injury or death.

 **Caution**
This signal word indicates a hazard with a low risk level which, if not avoided, can result in minor or moderate injury.

Note
This signal word indicates important information (e.g. material damage), but does not indicate hazards.

 **Info**
Information marked with this symbol helps you to carry out your tasks quickly and safely.

 **Follow the manual**
Information marked with this symbol indicates that the instructions must be observed.

 **Wear safety glasses**
Information marked with this symbol indicates that you should wear eye protection.

 **Wear protective gloves**
Information marked with this symbol indicates that you should wear protective gloves.

 **Wear a protective mask**
Information marked with this symbol indicates that you should wear a protective mask (FFP2 mask).

 **Wear foot protection**
Information marked with this symbol indicates that you should wear safety boots.

You can download the current version of the instructions via the following link:

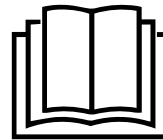

TAC V+ Tower
TAC M Tower



<https://hub.trotec.com/?id=44570>

Safety

Read this manual carefully before starting or using the device. Always store the manual in the immediate vicinity of the device or its site of use.

 **Warning**
Read all safety warnings and all instructions.
Failure to follow the warnings and instructions may result in electric shock, fire and/or serious injury.
Save all warnings and instructions for future reference.

This appliance can be used by children aged from 8 years and above and persons with reduced physical, sensory or mental capabilities or lack of experience and knowledge if they have been given supervision or instruction concerning use of the appliance in a safe way and understand the hazards involved.

Children shall not play with the appliance. Cleaning and user maintenance shall not be made by children without supervision.



Warning

Children of less than 3 years should be kept away from the device unless continuously supervised.

Children aged from 3 years and less than 8 years shall only switch on/off the appliance provided that it has been placed or installed in its intended normal operating position and they have been given supervision or instruction concerning use of the appliance in a safe way and understand the hazards involved.

Children aged from 3 years and less than 8 years shall not plug in, regulate and clean the appliance or perform user maintenance.

- Do not use the device in potentially explosive rooms or areas and do not install it there.
- Do not use the device in aggressive atmosphere.
- Only put up the device in an upright, stable position on firm ground.
- Let the device dry out after a wet clean. Do not operate it when wet.
- Do not use the device with wet or damp hands.
- Do not expose the device to directly squirting water.
- Never insert any objects or limbs into the device.
- Do not cover the device during operation.
- Do not sit on the device.
- This appliance is not a toy. Keep away from children and animals. Do not leave the device unattended during operation.
- Check accessories and connection parts for possible damage prior to every use of the device. Do not use any defective devices or device parts.
- Ensure that all electric cables outside of the device are protected from damage (e.g. caused by animals). Never use the device if electric cables or the power connection are damaged!
- The mains connection must correspond to the specifications in the Technical annex.
- Insert the mains plug into a properly fused mains socket.
- Observe the technical data when selecting extensions to the power cable. Completely unroll the extension cable. Avoid electrical overload.
- Before carrying out maintenance, care or repair work on the device, remove the mains plug from the mains socket. Hold onto the mains plug while doing so.
- Switch the device off and disconnect the power cable from the mains socket when the device is not in use.

- Check the power cable and mains plug for damage. If you notice damages, do not try to take the device back into operation. Order a new power cable with mains plug from Trotec and replace the defective power cable with mains plug with the new one.
Defective power cables pose a serious health risk!
- When positioning the device, observe the minimum distances from walls and other objects as well as the storage and operating conditions specified in the Technical annex.
- Make sure that the air inlet and outlet are not obstructed.
- Make sure that there are no loose items or dirt located in the immediate surroundings of air inlet and air outlet.
- Do not remove any safety signs, stickers or labels from the device. Keep all safety signs, stickers and labels in legible condition.
- Make sure that the suction side is kept free of dirt and loose objects.
- Dispose of replaced filters properly, especially after filtering substances hazardous to health.
- Never use the device as storage place or footstep.
- Do not move the device when switched on.

Intended use

Only use the device to clean atmospheric air whilst adhering to the technical data and the safety warnings. The device serves for air purification in highly frequented public areas, such as:

- Supermarkets and DIY stores
- Chemist's shops and pharmacies
- Electronic stores
- Gyms
- Waiting and reception areas
- Trade stands
- Dining rooms
- Emergency camps
- Ships
- Senior citizens home
- Schools
- Conference facilities
- Production halls

Moreover, the device serves for cleaning dust contaminated air in working zones. The device filters viruses, dust and micro fibres of paper and textiles directly at the workplace.

Foreseeable misuse

- Do not place the device on wet or flooded ground.
- Do not place any objects, e.g. clothing, on the device.
- Do not use the device out of doors.
- Do not use the device to siphon off vapours or fluids.
- Any use other than the intended use is regarded as a reasonably foreseeable misuse.
- Any unauthorised modifications, alterations or structural changes to the device are forbidden.

Personnel qualifications

People who use this device must:

- be aware of the dangers that occur when working with electrically driven air cleaners.
- have read and understood the instructions, especially the Safety chapter.

Instructed person

Instructed persons have been informed of the tasks they were entrusted with as well as of potential hazards resulting from inappropriate behaviour. They are allowed to operate and transport the device and perform simple maintenance activities (cleaning the housing, cleaning the fan).

The device is to be maintained and looked after by instructed personnel.

Residual risks



Warning of electrical voltage

Work on the electrical components must only be carried out by an authorised specialist company!



Warning of electrical voltage

Before any work on the device, remove the mains plug from the mains socket!
Do not touch the mains plug with wet or damp hands.
Hold onto the mains plug while pulling the power cable out of the mains socket.



Warning

Dangers can occur at the device when it is used by untrained people in an unprofessional or improper way!
Observe the personnel qualifications!



Warning

The device is not a toy and does not belong in the hands of children.



Warning

Risk of suffocation!
Do not leave the packaging lying around. Children may use it as a dangerous toy.

Note

Do not operate the device without an air filter inserted into the air inlet!

Without the air filter, the inside of the device will be heavily contaminated. This could reduce the performance and result in damage to the device.

Note

Do not use abrasive cleaners or solvents to clean the device.

Behaviour in the event of an emergency

1. Switch the device off.
2. In an emergency, disconnect the device from the mains feed-in: Hold onto the mains plug while pulling the power cable out of the mains socket.
3. Do not reconnect a defective device to the mains.

Information about the device

Device description

The device TAC V+ / TAC M (stationary) reduces the intensity and time aerosol particles and suspended matter stay in the air, effectively operating directly at the site of installation.

Wherever this high-performance air purifier will be positioned: Depending on the required air change rate, the device will produce a purified and filtered "clean air zone".

In this treatment zone, the surrounding air will be prevented from germs, fine particulates or other airborne micro particles since the device is able to perform large-volume air intakes of contaminated room air. All thanks to effective H14 HEPA filtration and a flexibly adjustable air circulation for the respective zone that will be free from aerosol particles.

In combination with the integrated F7 prefilter system, the Trotec H14 HEPA filter guarantees to separate airborne germs, viruses and dust, bacteria, spores or micro fibres from paper or textiles.

The TAC V+ Tower is equipped with a thermal self-regeneration function, automatically inactivating all viruses in regular intervals. This allows the filter to "regenerate" to 100 %.

This way, the device significantly reduces the airborne risk of infection in highly frequented public zones and guarantees dust-free working conditions in contaminated working zones.

Device depiction

Note

The figure depicts the TAC V+. The TAC V+ is provided with an air flap cover (1). The TAC M is provided with a discharge hood instead of an air flap cover.

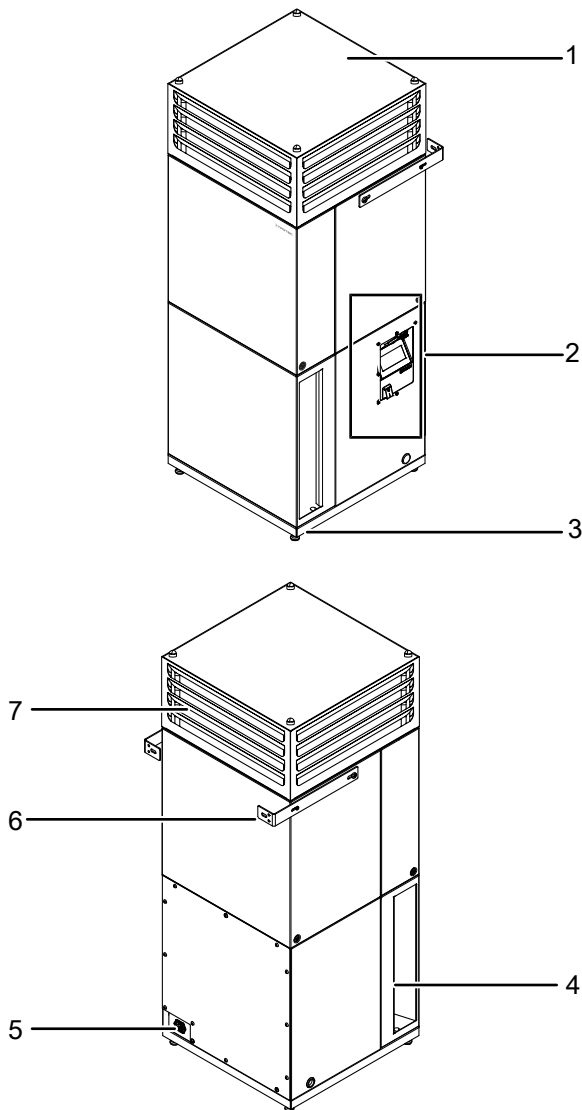

No.	Designation
1	TAC V+: Air flap cover TAC M: Discharge hood
2	Operating elements
3	Foot
4	Air inlet with air filter
5	Power cable connection
6	Wall holder (optional)
7	HEPA filter (inside the device)

Transport and storage

Note

If you store or transport the device improperly, the device may be damaged.

Note the information regarding transport and storage of the device.

Transport

To make the device easier to transport, it is fitted with wheels.



Wear foot protection

Wear suitable foot protection transporting the device.

Before transporting the device, observe the following:

- Switch the device off.
- Hold onto the mains plug while pulling the power cable out of the mains socket.
- Turn up the feet.
- Do not use the power cable to drag the device.
- Only wheel the device on a level and smooth surface.
- Remove all packing materials which serve to protect the device during transport.
- Should the device be damaged, please contact the responsible dealer or manufacturer, where the purchase was made.
- The device may only be lifted at the points provided with lifting gear intended for handling. The carrying capacity of the lifting gear must be suitable for the weight of the device (see technical data).

After transporting the device, proceed as follows:

- Set up the device in an upright position after transport.
- To ensure safe positioning, turn down the feet.

Storage

When the device is not being used, observe the following storage conditions:

- Store the device in a dry location and protected from frost and heat.
- Store the appliance in an upright position where it is protected from dust and direct sunlight.
- If required, use a cover to protect the device from invasive dust.
- Before restarting the device, check the condition of the power cable. If there are doubts as to the sound condition, contact the customer service.
- Have the device checked once a year by an electrically skilled person at any rate.

Assembly and installation

Scope of delivery

- 1 x Device
- 1 x air filter prefilter F7
- 1 x HEPA filter
- 1 x protective fleece
- 1 x Manual

Assembly

Aligning the device on feet

1. Before positioning, turn down the feet (3) so that the 4 wheels (8) are suspended in the air.
2. Fix the feet (3) with a lock nut by turning it clockwise. Only then the device will be in a stable position.

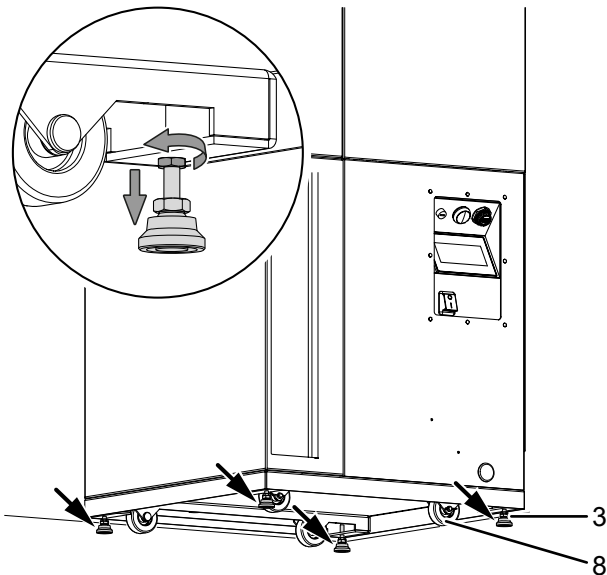

Start-up

When positioning the device, observe the minimum distance from walls or other objects as described in the chapter Technical annex.

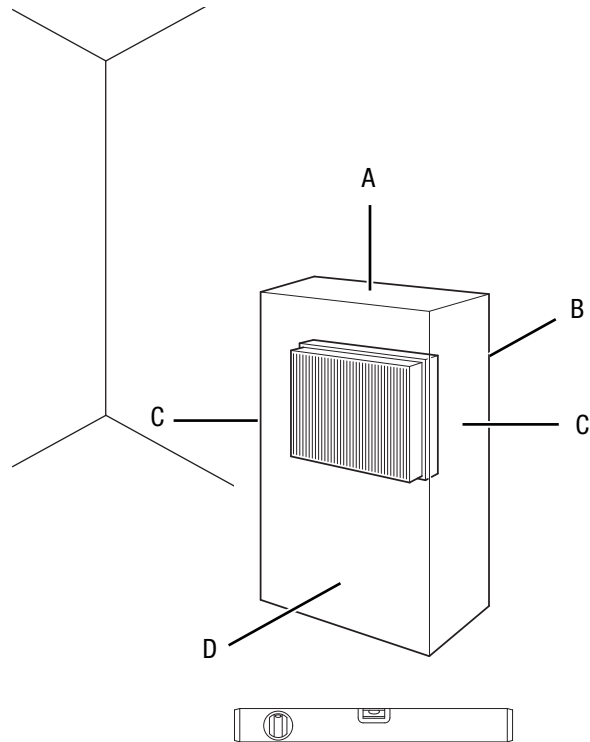

- The device may only be used in environments with no excessive formation of dust.
- Set the device up in an upright and stable position.
- Position the device on even and stable and ground in a way to prevent it from tipping over.
- When setting up the device, ensure a sufficient distance for air inlet and outlet as well as for operation (see Technical data).
- Make sure that extension cables are completely unrolled.
- When positioning the device, keep a sufficient distance to heat sources.
- Make sure that no curtains or other objects interfere with the air flow.

Inserting the air filter

Note

Do not operate the device without an air filter inserted into the air inlet!

Without the air filter, the inside of the device will be heavily contaminated. This could reduce the performance and result in damage to the device.

- Make sure that the air filter is installed before switching the device on.

Attaching a flowstop shutter

The optional flowstop shutters can be attached to one of the four insides of the tower. This prevents up to three sides of the tower from discharging air, e.g. if discharged air is not desired or not required on the respective side(s).

Attaching a FlowExtender Silence+

To reduce noise emission, you can optionally install one or more FlowExtender Silence+.

Attaching sound protection caps

To reduce the sound emission, you can attach additional optional sound protection caps.

Attaching mounting brackets

For additional securing of the device, the (optional) mounting brackets are recommended to fasten the device to the wall.

It is indispensable to use the mounting brackets if you want to use more than one FlowExtender Silence+.

Connecting the power cable

- Insert the mains plug into a properly fused mains socket.

Operation

Operating elements

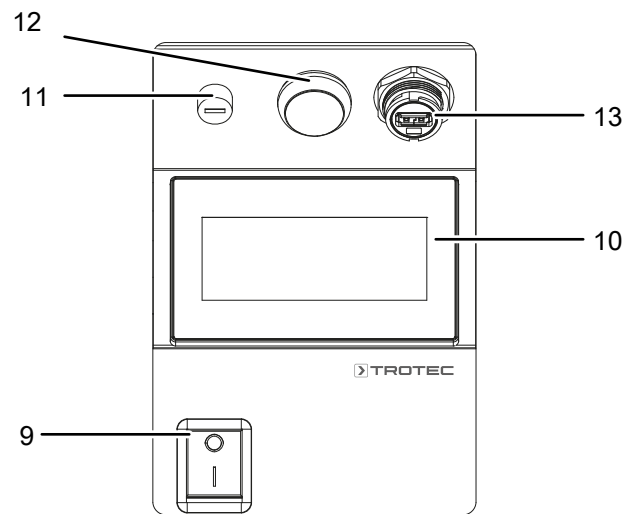

No.	Designation	Meaning
9	On/off switch	Switching the device on or off
10	Display	Selection of programmes and adjustment of parameters
11	Fusing for safety temperature limiter	Triggers in the event of overheating
12	Warning light	<ul style="list-style-type: none"> • Illuminated in green during operation • Illuminated in red in case of a fault • Illuminated in blue during filter regeneration • Flashes yellow filter change required • Flashes green during rundown
13	USB interface with locking cap	Update of the control software via USB flash drive with application software

Switching the device on

- Once you have completely installed the device as described in the Start-up chapter, you can switch it on.
- Press the *On/off* switch (9).
 - ⇒ The device is initialized.
 - ⇒ *Please wait* will be indicated on the display.
 - ⇒ Once the device has been initialised, the display switches to standby mode.

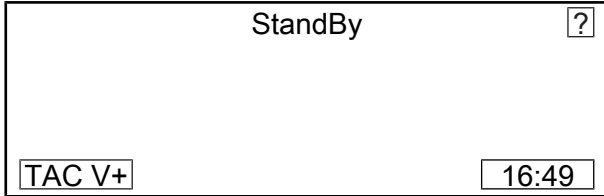

- Briefly touch the centre of the display.
 - ⇒ The main menu appears on the display.

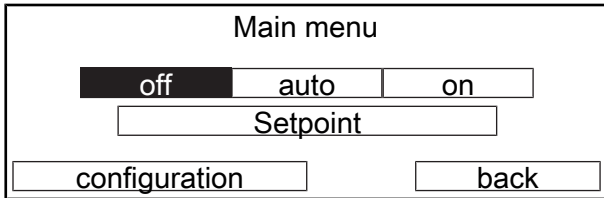

- If necessary, configure the device and adjust the setpoints (see chapters below).
- Start the device by actuating the *On* button.

Unlocking the screen

The screen lock is activated if no operating element was actuated for 20 seconds. *Locked* will be displayed.

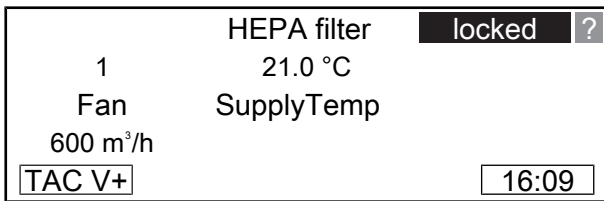

If you touch all other areas on the display apart from the *Locked* button, the following note will be displayed:

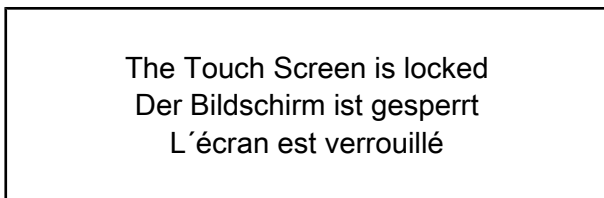

Please proceed as follows to unlock the screen lock:

- Press the *Locked* button for 2 seconds.
 - If a PIN has been previously set, press the *Locked* button and enter the PIN. Then press *Confirm*.
 - ⇒ The screen lock is released and *Locked* will no longer be indicated on the display.

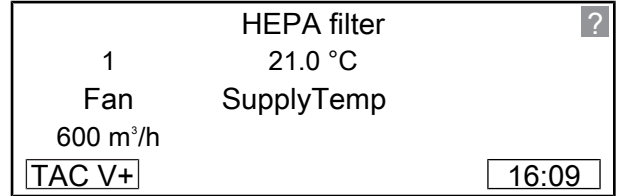

Note

If you forget the PIN, you will not be able to unlock the display. In this case you can request an emergency unlock code via the Trotec GmbH service hotline on +49 02452 962-730. The service hotline is available Monday to Thursday from 8 am to 5:30 pm and Friday until 5 pm. You need the date and time indicated on the display. You can view the information by pressing the time button.

Language setting

- Press the *Configuration* button in the main menu.
 - ⇒ Buttons for further settings will be indicated on the display.

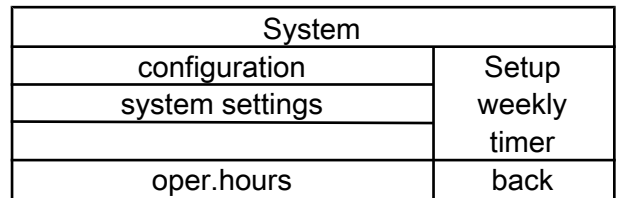

- Press the following buttons to select a language:
 - ⇒ *System settings*
 - ⇒ *Language setting*

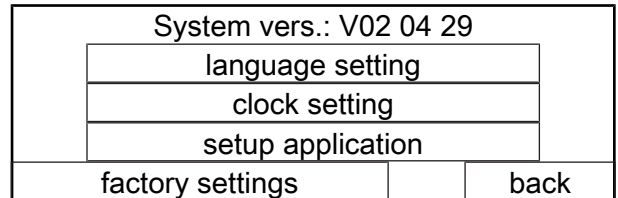

- Use the arrow buttons to select the desired language.
- Confirm the language selection by pressing the *Confirm* button.

Setting the time

1. Press the following buttons in the main menu to set the time:
 - ⇒ *Configuration*
 - ⇒ *System settings*
 - ⇒ *Clock setting*
2. Use the arrow buttons to set the time.
 - ⇒ The settings are applied immediately.
3. Press the *Back* button to exit the time settings.

Note

You can also set the time by releasing the screen lock and pressing the time button in the bottom right-hand corner of the main menu (see *Releasing the screen lock*).

Display

1. Press the following buttons in the main menu to make touchscreen settings:
 - ⇒ *Configuration*
 - ⇒ *System settings*
 - ⇒ *Setup application*

setup application		
Display	Keylock off	
Standby at Power on		
config w/o PW		
next		back

- ⇒ *Display*
2. Adjust the settings as desired:
 - ⇒ *Contrast*: Use the arrow buttons to set the contrast. Close the window by pressing the cross symbol in the upper right-hand corner.
 - ⇒ *Touch beep on/off*: Press the button to switch the touch tone on or off.
3. Press the *Back* button to return to the main menu.

Setting the screen lock

1. Press the following buttons in the main menu to set the screen lock:
 - ⇒ *Configuration*
 - ⇒ *System settings*
 - ⇒ *Setup application*
2. Press the *Key lock off* button several times to select the following settings one by one:
 - ⇒ *Key lock off*: The screen lock is deactivated.
 - ⇒ *Screen lock on*: The screen lock is activated.
 - ⇒ *Screen lock on with PIN*: The screen lock is activated and a PIN is required to unlock the screen. If you select the *Screen lock on with PIN* setting, a screen for entering a PIN appears on the display. The PIN can be freely selected. Press the *Accept* button to confirm the PIN entry. If you forget the PIN, you can request an emergency unlock code from Trotec. To cancel the PIN entry at this point, press the *Back* button.

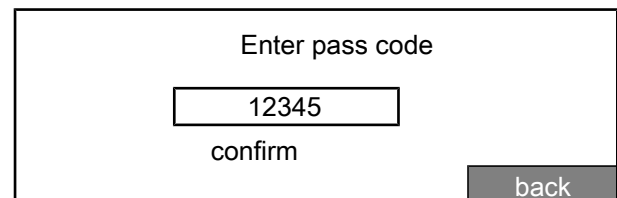

3. Press the *Back* button to return to the main menu.

Locking the configuration settings

1. Press the following buttons in the main menu to secure the configuration settings against unauthorised access:
 - ⇒ *Configuration*
 - ⇒ *System settings*
 - ⇒ *Setup application*
2. Press the *Config w/o PW* button to select the following settings one by one:
 - ⇒ *Config w/o PW*: The configuration settings are not locked.
 - ⇒ *Config. with PW*: A user password is required to open the screens from *Configuration*. The user password is **1** by default. The configuration screens can be opened until the user is automatically logged out after 15 minutes. Logging off manually is possible in the *Factory settings* screen.
3. Press the *Back* button to return to the main menu.

Automatic restart function

1. Press the following buttons in the main menu to set the automatic restart function:
 - ⇒ *Configuration*
 - ⇒ *System settings*
 - ⇒ *Setup application*
2. Press the *Standby at Power on* button or the *Automatic restart* button to select in which mode the device should start when the *On/off* switch is pressed.
 - ⇒ *Standby at Power on*: The device starts in standby mode.
 - ⇒ *Automatic restart function*: The device will start in the last set mode.
3. Press the *Back* button to return to the main menu.

Setting the fan boost

The current fan stage can be overdriven with the fan boost function for a limited time by a certain air flow rate.

1. Press the following buttons in the main menu to set the fan boost:
 - ⇒ *Configuration*
 - ⇒ *System settings*
 - ⇒ *Setup application*
 - ⇒ *next*

setup application		
boost enabled	1050 m ³ /h	12 min
silent enabled	23.0 %	5 min
next	back	

2. Press the *Fan boost* button to select between *Boost enabled* and *Boost disabled*.
 - ⇒ *Boost enabled*: The fan boost function is active.
 - ⇒ *Boost disabled*: The booster function is not active.
3. Press the *m³/h* button to set the air flow rate.
4. Press the *min* button to set the duration.

5. Press the *Back* button to return to the main menu.
 - ⇒ If the Fan boost function is active, the *Fan boost* button appears on the basic screen. After pressing the button, the fan runs for the set duration with the set air flow rate, regardless of the previously selected fan speed. During this time, the *Fan boost* and *Fan* buttons flash alternately. The remaining time is displayed. The Silent function can also be operated with and without PIN entry when the screen lock is activated.
 - ⇒ If the duration is set to 0 minutes, the time limit is reversed. The function remains active until it is deselected, a fan speed of your choice is selected in the display or the weekly timer switches on another function.
 - ⇒ If the Silent function and/or Fan boost function are activated, the *Silent* and *Boost* buttons are displayed next to each other.

HEPA filter			?
1	21.0 °C	12 min	
Fan	SupplyTemp	Duration	
600 m ³ /h			
TAC V+	Silent	Boost	16:09

Setting the Silent function

The Silent function allows you to adjust the fan speed and the fan speed duration.

1. Press the following buttons in the main menu to set the silent boost:
 - ⇒ *Configuration*
 - ⇒ *System settings*
 - ⇒ *Setup application*
 - ⇒ *Next*

setup application		
boost enabled	1050 m ³ /h	12 min
silent enabled	23.0 %	5 min
next	back	

2. Press the *Silent* button to select between *Silent enabled* and *Silent disabled*.
 - ⇒ *Silent enabled*: The Silent function is active.
 - ⇒ *Silent disabled*: The Silent function is not active.
3. Press the *m³/h* button to set the air flow rate.
4. Press the *min* button to set the duration.

5. Press the *Back* button to return to the main menu.

- ⇒ If the Silent function is active, the *Silent* button appears on the basic screen. After pressing the button, the fan runs for the set duration with the set air flow rate, regardless of the previously selected fan speed. If the Silent function is active, the fan speed and air flow rate are not displayed. The *Silent* button flashes. The remaining time is displayed. The Silent function can also be operated with and without PIN entry when the screen lock is activated.
- ⇒ If the duration is set to 0 minutes, the time limit is reversed. The function remains active until it is deselected, a fan speed of your choice is selected in the display or the weekly timer switches on another function.
- ⇒ When Silent function and Fan boost function are activated, the *Silent* and *Boost* buttons are displayed next to each other.

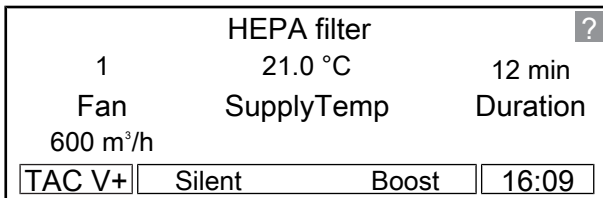

Activating hygiene alarm

If the hygiene alarm is activated, hygiene maintenance is recommended after 4,000 operating hours.

1. Press the following buttons in the main menu to activate hygiene alarm:
 - ⇒ *Configuration*
 - ⇒ *System settings*
 - ⇒ *Setup application*
 - ⇒ *next*

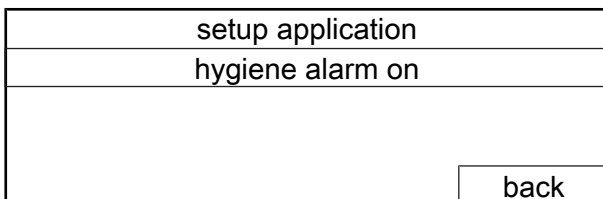

2. Press the *Hygiene alarm off* button to select the following settings one by one:
 - ⇒ *Hygiene alarm off*: Hygiene alarm is inactive.
 - ⇒ *Hygiene alarm on*: Hygiene alarm is active.
3. Press the *Back* button to return to the main menu.

Setting the timer

1. Press the *Configuration* button in the main menu.
2. Press the *Configuration* button again in the following screen.
3. Select *Timer* in the settings.
 - ⇒ *Run on timer* appears on the display.

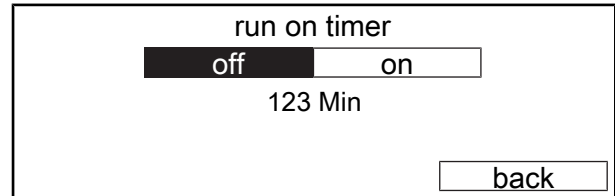

4. Activate the timer by pressing the *On* button.
5. Adjust the setpoint for the treatment duration by pressing the time button or by selecting the value using the arrow buttons.

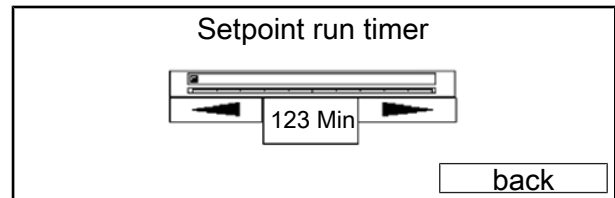

- ⇒ The adaptation will be adopted without any further confirmation.
- ⇒ Once the device is switched on, the timer starts running and will switch off the device after the set time has been expired.

Weekly timer

Please proceed as follows to set switching times by means of the weekly timer:

1. Press the *Configuration* button in the main menu.
 - ⇒ Buttons for further system settings will be indicated on the display.

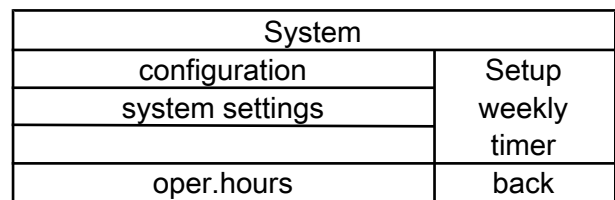

2. Press the *Setup Weekly Timer* button.
 - ⇒ The list for the switching times will be indicated on the display.

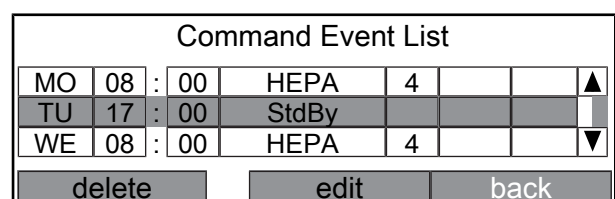

3. Select a switching time by means of the arrow buttons.
4. Press the *Delete*, *New* or *Edit* buttons to adjust the settings as required.

⇒ *Delete*: Delete the selected switching time.

Confirmation of deletion					
TU	17	:	00	StdBy	
delete			back		

⇒ *New*: Add a new switching time.

⇒ *Edit*: Change the selected switching time.

Command Event			
Monday	12	:	12
StandBy	Fan		
		confirm	
		cancel	

5. Optional: Press the *Fan* button to select the fan stage for the selected switching time.

⇒ The *Setpoint Fan speed* screen will be indicated on the display.

Setpoint Fan speed		
1	2	3
4	5	6
max	1000 m ³ /h	back

6. Press on a setpoint stage in order to select it for the selected switching time.
7. Press *no change* in order to keep the fan stage that has already been set.
8. Press *Back* in order to return back to the *Command Event* screen.
9. Press the indicated switching state (*StandBy* in this example) on the display with the system settings in order to change the switching state.

Command Event			
Monday	12	:	12
StandBy	Fan		
		confirm	
		cancel	

⇒ The possible switching states are indicated on the display.

10. Press the *Standby* or *HEPA filter* switching state to confirm the switching state or to select another.

Command	
StandBy	HEPA filter
back	

11. Press *Back* in order to return back to the display with the system settings.

System	
configuration	Setup weekly timer
system settings	
oper.hours	back

12. Press *Back* in order to return back to the main menu.
13. Press the *Auto* button in the main menu to activate the current switching time.

⇒ The *On* and *Off* buttons will remain active.

Main menu	
off	auto
Setpoint	
configuration	back

Setting the fan stage

You can set the fan stage for normal mode directly via the main menu. The fan stage settings for normal mode and switching time can be independently adjusted from another.

1. Press the *Setpoints* button in the main menu.
 - ⇒ Buttons for adjusting the fan stages will be indicated on the display.
2. Press the buttons *1, 2, 3, 4, 5, 6* or *max* to select a fan stage.
 - ⇒ The selected setpoint appears on the display.

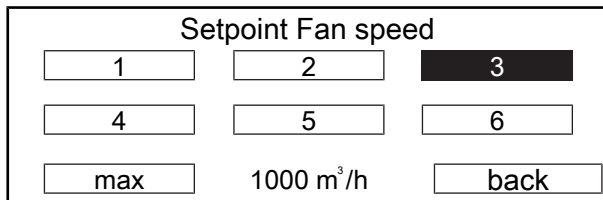

3. Press the *Back* button to return to the main menu.

Setpoint stages

Setpoint stage	Air volume value in m ³ /h	Filter class* Standard filter
1	600 m ³ /h	H14
2	750 m ³ /h	H14
3	900 m ³ /h	H14
4	1050 m ³ /h	H14
5	1200 m ³ /h	H14
6	1400 m ³ /h	H13
Max.	2100 m ³ /h	E12

* At an air volume flow of more than 1200 m³/h the filter class of the H14 HEPA standard filter will be reduced. Using the optional Ultra HighFlow H14 HEPA filter allows for a higher air volume flow in filter class H14. With an air current of more than 1800 m³/h the filter class of the filter is reduced from H13 to E12.

Filter regeneration (TAC V+ only)



Warning

Do **not** switch off the device during filter regeneration or decontamination!

1. Press the *Configuration* button in the main menu.
 - ⇒ Buttons for further system settings will be indicated on the display.
2. Press the *Regenerate filter* button.
 - ⇒ The following display opens.

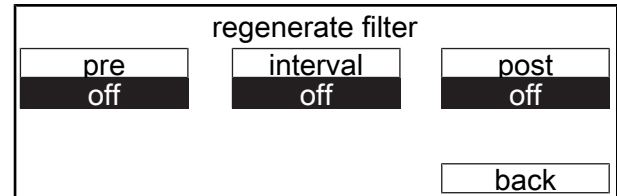

⇒ The enabled buttons are shown in black.

3. Press one or several buttons to activate filter regeneration as follows.
 - ⇒ pre: filter regeneration is carried out before air cleaning operation.
 - ⇒ interval: filter regeneration is always carried out after a certain air cleaning operating time. If this function is activated, the set time will be shown on the screen.
 - ⇒ post: filter regeneration is carried out after air cleaning operation.



Info

Combinations of all three settings are possible, as shown on the screen below.

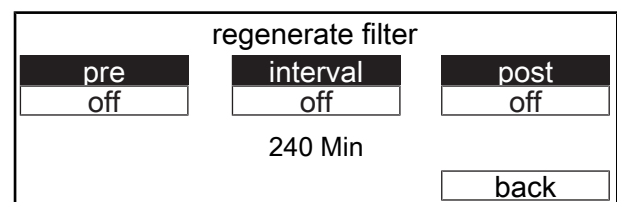

4. If *Interval* is selected, press the displayed time to adjust the time using the arrow buttons or by entering it directly.
 - ⇒ During decontamination, the filter will be heated to 100 °C; the interval is 30 minutes.
 - ⇒ The warning light (12) is illuminated in blue during filter regeneration.



Warning

Do **not** switch off the device during filter regeneration or decontamination!

Recommendations for filter regeneration:

Under normal environmental conditions, such as those prevailing in offices, schools, kindergartens or public buildings, it is sufficient to regenerate the filter once a week. If the air purifier is used in cool areas with high humidity levels, e.g. in slaughterhouses or in the food industry in general, we recommend to regenerate the filter daily.

Note

During decontamination, an odour may be produced, which is harmless.

Note

The software monitors whether filter regeneration is carried out regularly. After 50 hours of air cleaning operation, a message appears with the option of starting filter regeneration immediately. If filter regeneration is not started at this time, the number of days by which filter regeneration is overdue will be displayed each time the device is switched on.



Info

Filter regeneration is linked to the weekly timer. This means that if a start time of 08:00 is set in the list for the switching times and *pre* is selected for filter regeneration, the device will start filter regeneration at 8:00 a.m. and change over to air cleaning after 30 minutes. If *post* is selected, filter regeneration will be activated as soon as the device is switched to standby.

Switch-off

1. If necessary, deactivate the screen lock.
2. Touch the display to go to the main menu.
3. Press the *Off* button in the main menu.
 - ⇒ The device is now in standby mode.
4. Actuate the *On/off* switch (9).
 - ⇒ The device is switched off.

Shutdown



Warning of electrical voltage

Do not touch the mains plug with wet or damp hands.

1. Proceed as described in the Switch-off section.
2. Remove the mains plug from the mains socket.
3. Clean the device according to the Maintenance chapter.
4. Store the device according to the Storage chapter.

Available accessories



Warning

Only use accessories and additional equipment specified in the instructions. Using insertion tools or accessories other than those specified in the instructions may cause a risk of injury.



Warning

In order to prevent a potential fire hazard, only use the original Trotec **heat-resistant H14 HEPA filter**.

Designation	Article number
Heat-resistant H14 HEPA filter	7.160.000.106
Prefilter F7	7.160.000.115
Attachment hood for hose connection	6.100.007.061
Prefilter fleece (black)	7.160.000.458
Flowstop shutter	6.100.007.063
Protective fleece for the air outlet	7.160.000.459
FlowExtender Silence+ (basalt grey)	6.100.007.066
FlowExtender Silence+ (yellow)	6.100.007.068
FlowExtender Silence+ (bronze)	6.100.007.069
FlowExtender Silence+ (white)	6.100.007.070
Wall holder	6.100.007.073
Sound protection caps	6.100.007.072

Errors and faults

The device has been checked for proper functioning several times during production. If malfunctions occur nonetheless, check the device according to the following list.

The device does not start:

- Check the power connection.
- Check the power cable and mains plug for damage.
- Check the on-site fusing.
- The safety thermostat might have tripped due to overheating. Switch the device off and let it cool down for at least 10 minutes.
- Wait for 10 minutes before restarting the device. If the device is not starting, have the electricians checked by a specialist company or by Trotec.
- The overheating protection may have been tripped. Have a specialist electrical company or Trotec check the electricians and replace the overheating protection.

The device is loud or vibrates:

- Check whether the device is set up in a stable and upright position.

The device gets very warm, is loud or is losing performance:

- Check the air inlets and air filters for dirt. Remove external dirt.
- From the outside, check the device for dirt (see chapter Maintenance). If the inside of the device is dirty, have it cleaned by a specialist company or by Trotec.

Note

The device warms up during decontamination (TAC V+ only). Check whether the device is in filter regeneration mode.

There can be several reasons for your air cleaner emitting an unpleasant smell.

The filter is heated to 100 °C during filter regeneration (TAC V+ only). As this process is about regeneration and drying, different odours may occur due to high temperatures. However, all of these odours are safe and harmless. A new filter emits odours upon the first filter regenerations. This is a normal and harmless procedure. Depending on the application purpose and the number of filter regenerations, odorous substances can be released, e.g. caused by existing moisture which evaporates, dust or organic and inorganic suspended particles which are bound in the filter. All odours produced here are harmless to health and result from the thermal treatment to regenerate the filter.

The device still does not operate correctly after these checks:

Please contact the customer service. If necessary, bring the device to an authorised specialist electrical company or to Trotec for repair.

Error messages

Faults are indicated by the warning light (12) lighting up. Additionally, the following error messages can be indicated on the display (10):

Message	Cause	Troubleshooting
Volumetric flow rate too low	Covered or blocked inlet or outlet or defective fan	Remove the blockages.
Sensor fault	One of the temperature sensors is defective	Switch the device off and check the temperature sensors.
Filter dirty (Warning light (12) flashes)	The air filter might be contaminated	Replace the filter.
No error message (Warning light (12) flashes)	The device was switched off too early	Set the device to "off" and wait for 20 seconds. Use the <i>On/off switch</i> (9) to switch the device off and wait for 10 seconds. Switch the device back on.
Overheating protection motor	The device is overheating	Disconnect the device from the mains and allow it to cool down.

Maintenance

The device is designed for long hours of operation with minimum maintenance effort. Safe operation of the device requires all built-in components, especially the safety temperature limiter (STB), to be checked and cleaned after 12 months at the latest or after 4000 operating hours as well as all damaged components to be replaced.

In order to benefit from an optimal operation of the air cleaner we recommend using our maintenance service once a year. The maintenance service consists of changing the filter, cleaning and disinfecting the interior and exterior of the device, checking functions and all safety devices and, if required, updating the control software. This way you ensure your device to maintain a perfectly clean condition while reliably filtering and decontaminating viruses and aerosols from the room air for many ongoing years – without you needing to worry about it anymore. We'll get in touch with you regarding your service intervals. For an all-round safe operation, we recommend concluding a maintenance agreement. Please contact our customer service.

Maintenance intervals

Maintenance and care interval	before every start-up	as needed	at least every 4 weeks	at least every 6 months	at least annually	TAC V+ Tower 3-4 years / depending on the particle pollution in the air*	TAC M Tower 2-3 years / depending on the particle pollution in the air**
Check air filter, air inlets and outlets for dirt and foreign objects and clean if necessary	X						
Exterior and interior cleaning		X			X		
Visually check the inside of the device for dirt		X	X				
Replace the H14 filter						X	X
Replace the F7 filter				X			
Check for damage	X						
Clean or replace the protective fleece at the air outlet		X					
Clean or replace the prefilter fleece		X					
Checking the safety temperature limiter					X		
Check the attachment screws		X			X		
Test run					X		
* with thermal decontamination							
** without thermal decontamination							

Maintenance and care log

Device type:

Device number:

Maintenance and care interval	1	2	3	4	5	6	7	8	9	10	11	12	13	14	15	16
Check air filter, air inlets and outlets for dirt and foreign objects and clean if necessary																
Clean the exterior																
Visually check the inside of the device for dirt																
Replace the H14 filter																
Replace the F7 filter																
Check for damage																
Check the attachment screws																
Test run																
Remarks:																

1. Date: Signature:	2. Date: Signature:	3. Date: Signature:	4. Date: Signature:
5. Date: Signature:	6. Date: Signature:	7. Date: Signature:	8. Date: Signature:
9. Date: Signature:	10. Date: Signature:	11. Date: Signature:	12. Date: Signature:
13. Date: Signature:	14. Date: Signature:	15. Date: Signature:	16. Date: Signature:

Activities required before starting maintenance



Warning of electrical voltage

Do not touch the mains plug with wet or damp hands.

- Switch the device off.
- Hold onto the mains plug while pulling the power cable out of the mains socket.



Warning of electrical voltage

Tasks which require the device to be opened must only be carried out by authorised specialist companies or by Trotec.



Warning

Observe local provisions and regulations on hygiene when cleaning. Protect yourself during cleaning and maintenance work with suitable protective equipment (e.g. protective mask, protective glasses and gloves).



Note

Prior to cleaning the interior, protect the fan and further electrical components from water ingress with appropriate means.

Note

In case of maintenance pending, a respective message will be indicated on the display.

Cleaning the housing

Clean the housing with a soft, damp and lint-free cloth. Make sure that no moisture enters the housing. Protect electrical components from moisture. Do not use any aggressive cleaning agents such as cleaning sprays, solvents, alcohol-based or abrasive cleaners to dampen the cloth.

Visual inspection of the inside of the device for dirt

1. Remove the air filters.
2. Use a torch to illuminate the openings of the device.
3. Check the inside of the device for dirt.
4. If you see a thick layer of dust, clean the inside of the device with a vacuum cleaner.
5. Reinsert the air filters.

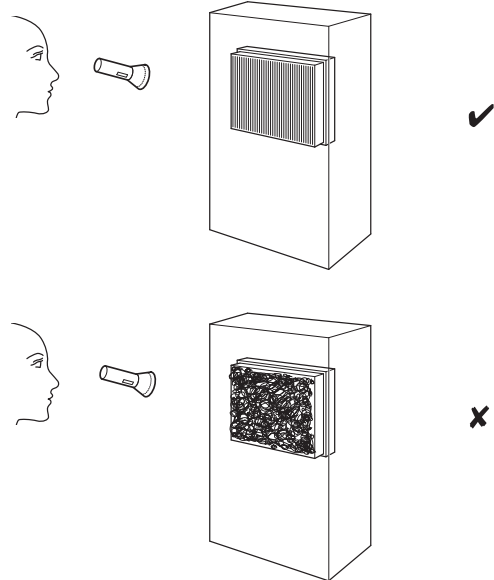

Filter change



Warning

Use an FFP2 mask and disposable gloves when changing the filter.



The filter change intervals depend on the degree of air pollution and the filter quality. Dirty filters impair the performance ability of the device. If the filter is contaminated to a certain degree, a warning will be indicated on the display and a new filter has to be inserted.

Note

The figure depicts the TAC V+. The TAC V+ is provided with an air flap cover (1). The TAC M is provided with a discharge hood instead of an air flap cover.

Please proceed as follows to change the H14 HEPA filter:

- ✓ Automatic thermal self-regeneration is completed (TAC V+ only).
- 1. **TAC V+:** Disassemble the air flap cover (1) by loosening the four screws and taking off the air flap cover.
TAC M: Disassemble the discharge hood by loosening the four screws and taking off the discharge hood.

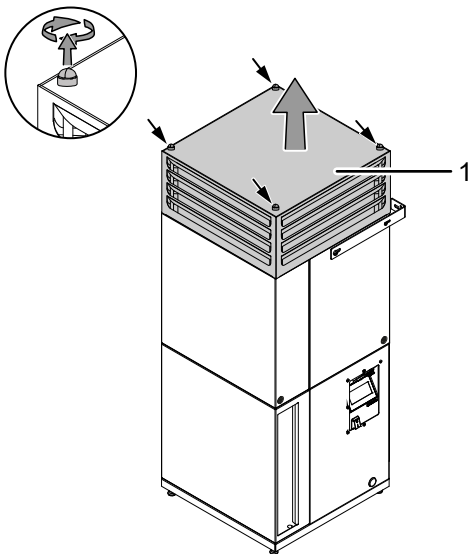

2. Remove the H14 HEPA filter (7) from the device.

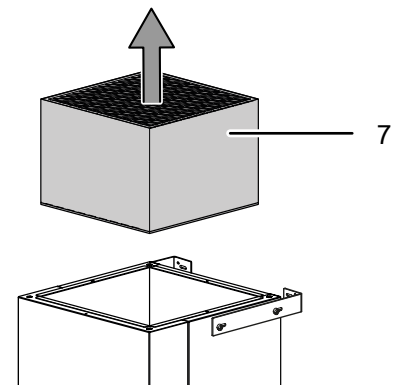

3. Put the worn H14 HEPA filter (7) in a bag and dispose of it in the household waste.
4. Thoroughly clean the housing from the inside and outside (see Cleaning the housing).
5. Insert a new HEPA air filter (7).
6. **TAC V+:** Put the air flap cover (1) back on the device and tighten the four screws from above.
TAC M: Put the discharge hood back on the device and tighten the four screws from above.

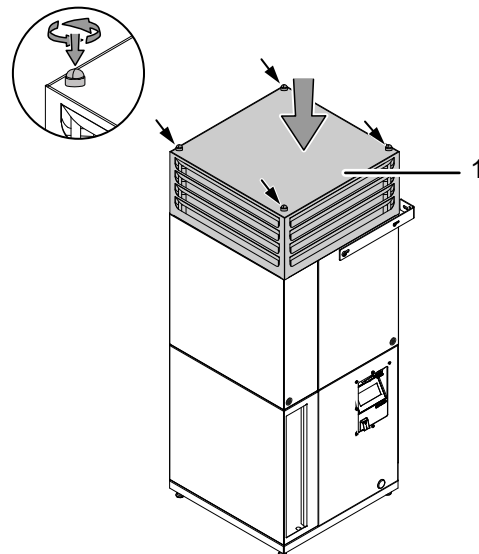

Info

If a warning to change the F7 filter is displayed, first check whether the prefilter fleece is dirty. If you have replaced or cleaned the prefilter fleece and the warning message is still indicated, replace the F7 filter with a new one.



Info

TAC M: The protective fleece on the air outlet of the discharge hood prevents objects from entering the device from above. The protective fleece is fixed with Velcro® dots. Inspect and clean the protective fleece regularly.

Please proceed as follows to change the F7 filter:

1. Loosen the screws on the air inlet (4) on both sides and pull out the air inlet towards the front of the device.
2. Remove the air filter.

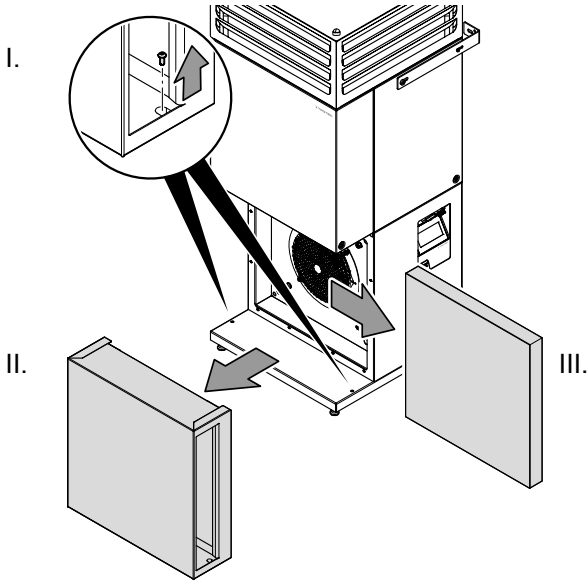

3. Insert the new air filter into the device.
4. Put the air inlet (4) back on the device and tighten the screws on both insides of the device.

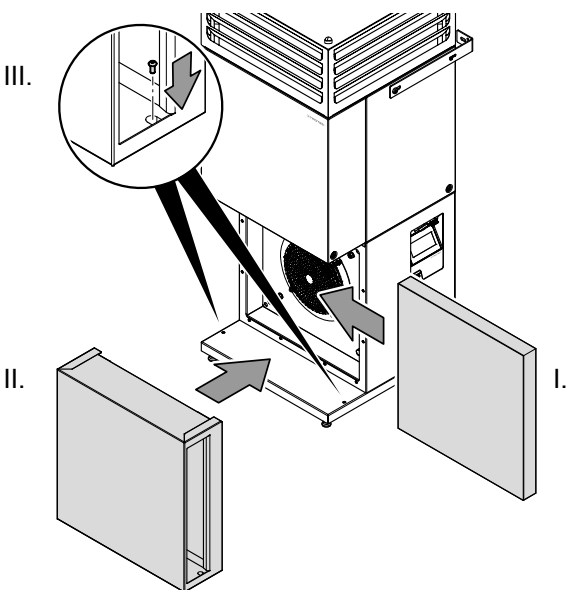

In order to reset the hours counter for the filter, proceed as follows:

1. Press the following buttons in the main menu:
 - ⇒ *Configuration*
 - ⇒ *System settings*
 - ⇒ *Factory settings*
 - ⇒ *Enter pass code*
2. Press *0*.
3. Enter the user password. The user password is **1** by default.
4. Press the *Confirm* button, then actuate the following buttons:
 - ⇒ *Back* (3 x)
 - ⇒ *Oper. hours*
 - ⇒ *Service counter*
5. Press the *Reset* button in the corresponding line of the changed filter.
 - ⇒ The counter is reset to zero hours.

Checking the safety temperature limiter

If the safety temperature limiter (11) has triggered, allow the device to cool down. Then twist off the protective cap and press the fusing into the device until it locks into place.

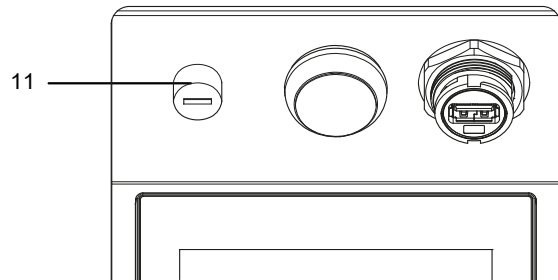

Technical annex
Technical data

Parameter	Value	
Model	TAC V+	TAC M
Article number	1.580.010.150 1.580.010.151 1.580.010.152 1.580.010.153	1.580.010.145 1.580.010.146 1.580.010.147 1.580.010.148
Max. air volume (standard H14 HEPA filter) Max. air volume in filter class (approx.)	2100 m ³ /h H14 ≤ 1200 m ³ /h H13 ≤ 1400 m ³ /h	2100 m ³ /h H14 ≤ 1200 m ³ /h H13 ≤ 1400 m ³ /h
Possible clean air zone	Depending on the air change rate per hour (ACH) required in the hygiene concept as well as on the required filter performance efficiency (H14 or H13)	Depending on the air change rate per hour (ACH) required in the hygiene concept as well as on the required filter performance efficiency (H14 or H13)
Prefilter for air filter	F7 (EN 779:2002), ePM10 85 % (ISO 16890)	F7 (EN 779:2002), ePM10 85 % (ISO 16890)
High-temperature particulate air filter	TROTEC HEPA H14 Heat Resistant (EN 1822)	TROTEC HEPA H14 Heat Resistant (EN 1822)
Mains connection	220-240 V, 50 / 60 Hz	220-240 V, 50 / 60 Hz
Average power consumption	0.14 kW for 900 m ³ /h air volume 1.25 kW short-term peak load, only during filter regeneration, maximum (without filter regeneration) 0.79 kW	0.14 kW for 900 m ³ /h air volume 0.75 kW maximum
Connection plug	CEE 7/7, H07RN-F	CEE 7/7, H07RN-F
Type of protection	IP23	IP23
Max. current consumption	5.5 A	3.5 A
Max. sound level (distance 1 m)	29 dB(A) – 50 dB(A)*	29 dB(A) – 50 dB(A)*
Dimensions (length x width x height)	506 x 523 x 1270 mm 770 mm (width with optional sound protection caps)	506 x 523 x 1100 mm 770 mm (width with optional sound protection caps)
Minimum distance to walls and other objects:	top (A): 10 cm rear (B): 10 cm sides (C): 50 cm front (D): -	50 cm 10 cm 50 cm -
Weight (filter included)	86.5 kg	76.7 kg

*Sound pressure level according to ISO 11203 in dB(A), depending on configuration (sound protection caps, FlowExtender Silence+)

Circuit diagram

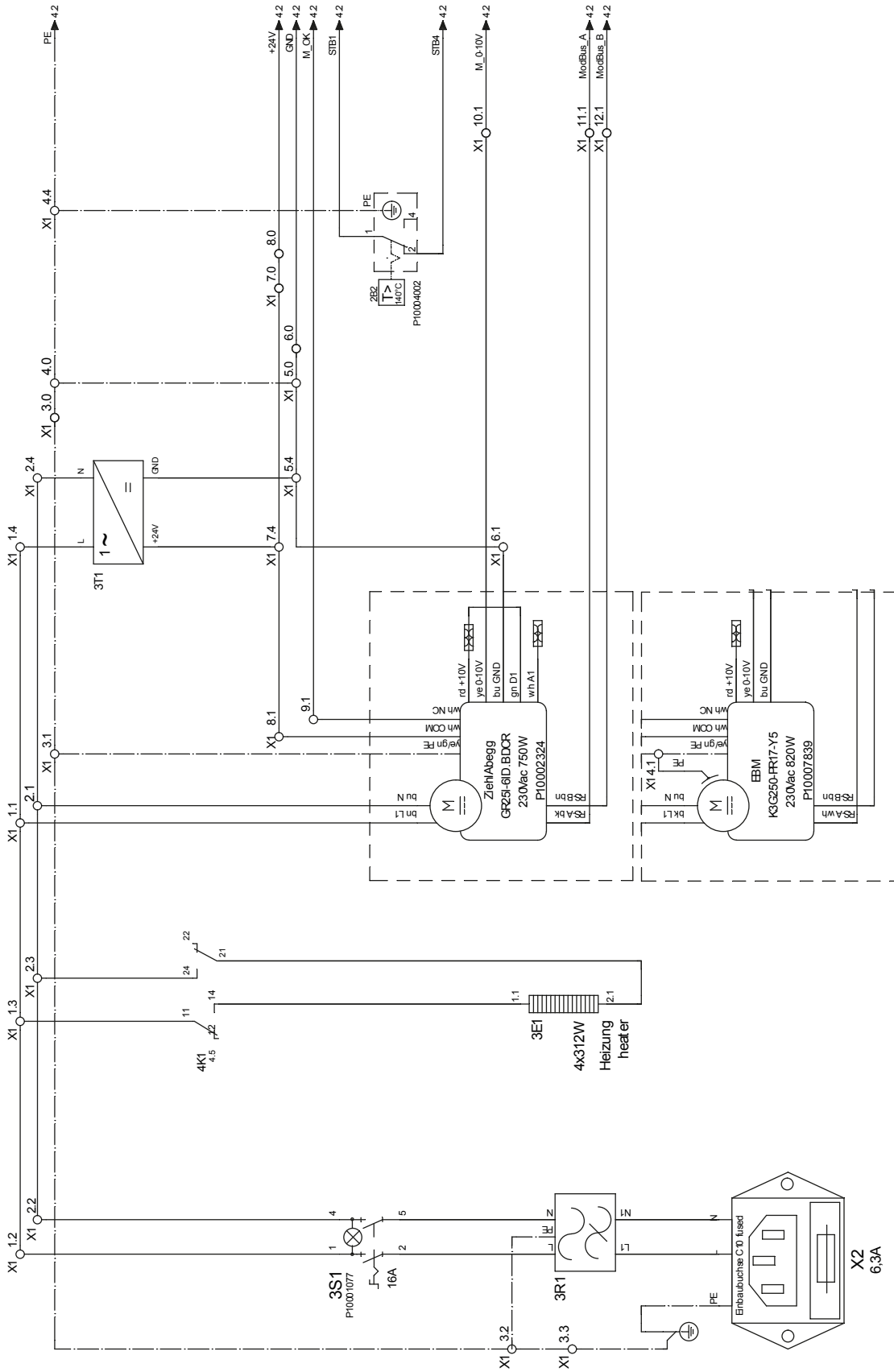

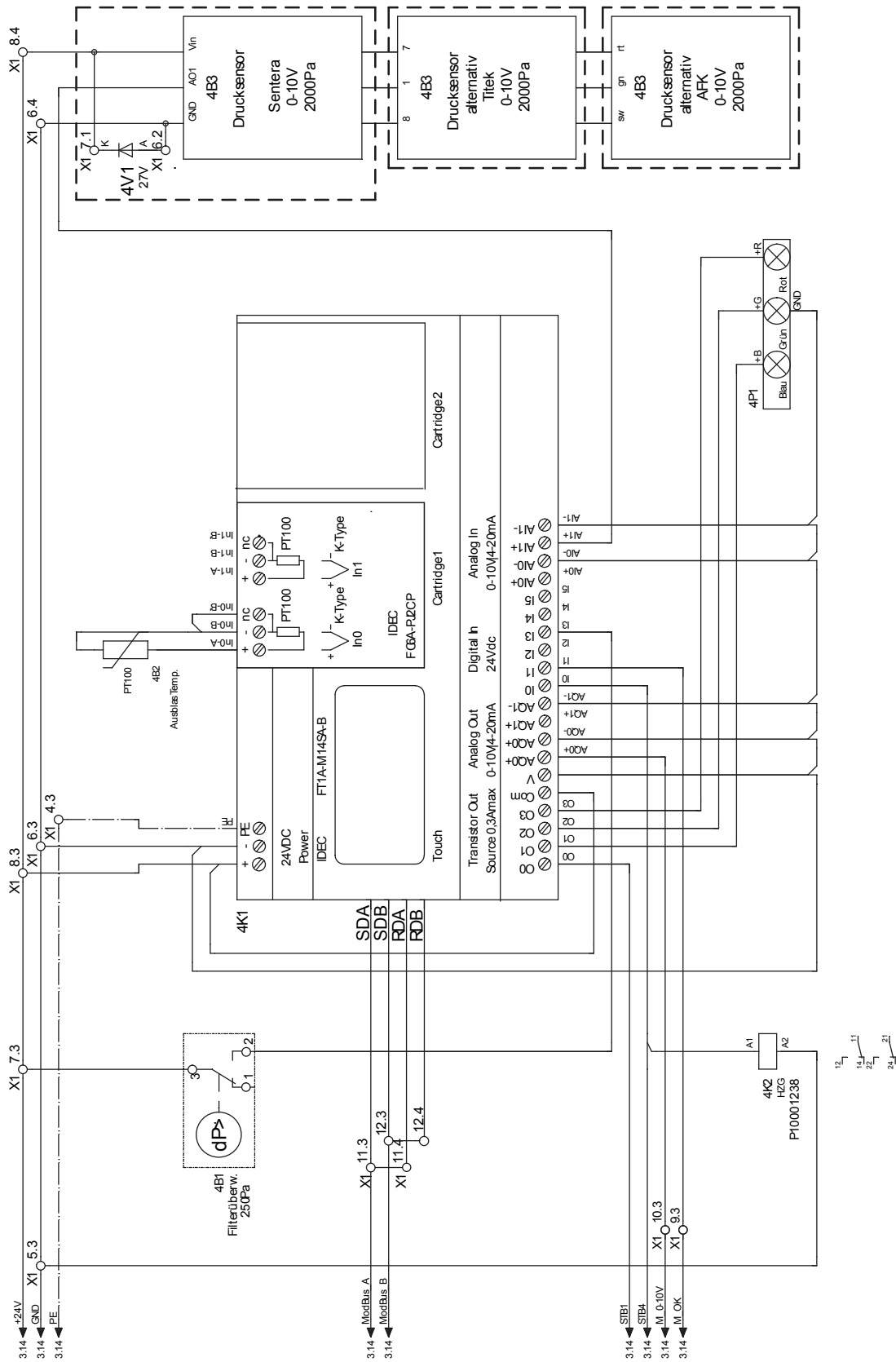

Spare parts drawing and list



Info

The position numbers of the spare parts differ from those describing the positions of the components mentioned in these instructions.

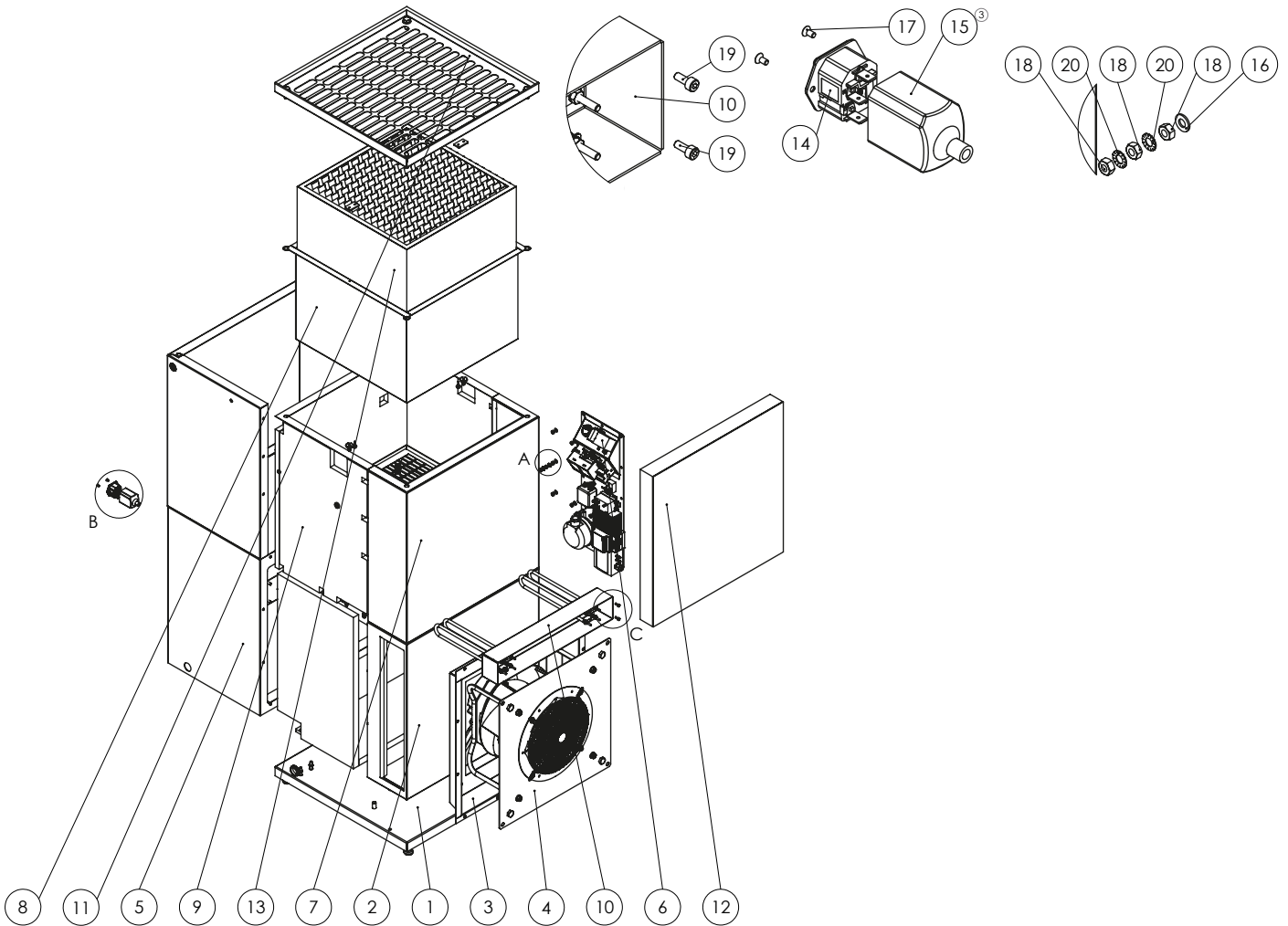

No.	Spare part	No.	Spare part
1	Foot (T0001463)	11	Discharge hood (T0001209)
2	Fan box (T0001201)	12	Air filter (T0000195)
3	Fan holder (T0000734)	13	Air filter (HEPA H14, 418x418x292 + heat-resistant gasket)
4	Fan (T0001202)	14	Mains connection (PF0001-63)
5	Tower, basalt grey (T0001543)	15	PVC insulating cap (T0001762)
6	Standard (T0001354)	16	Detent-edged washer (SSK5, VZ galv., shape K)
7	Filter box (T0001208)	17	Hexagon socket countersunk screw (DIN 7991 – M 3 x 6)
8	Filter case (T0001567)	18	Hexagon nut (nut DIN 934 M5 VZ galv.)
9	Insulation top part (T0001358)	19	Cylinder Allen screw (DIN 912 M04x10 VZ galv.)
10	Heater (T0001348)	20	Countersunk serrated lock washer (DIN 6798 – A Ø5.3)

Operating panel



Info

The position numbers of the spare parts differ from those describing the positions of the components mentioned in these instructions.

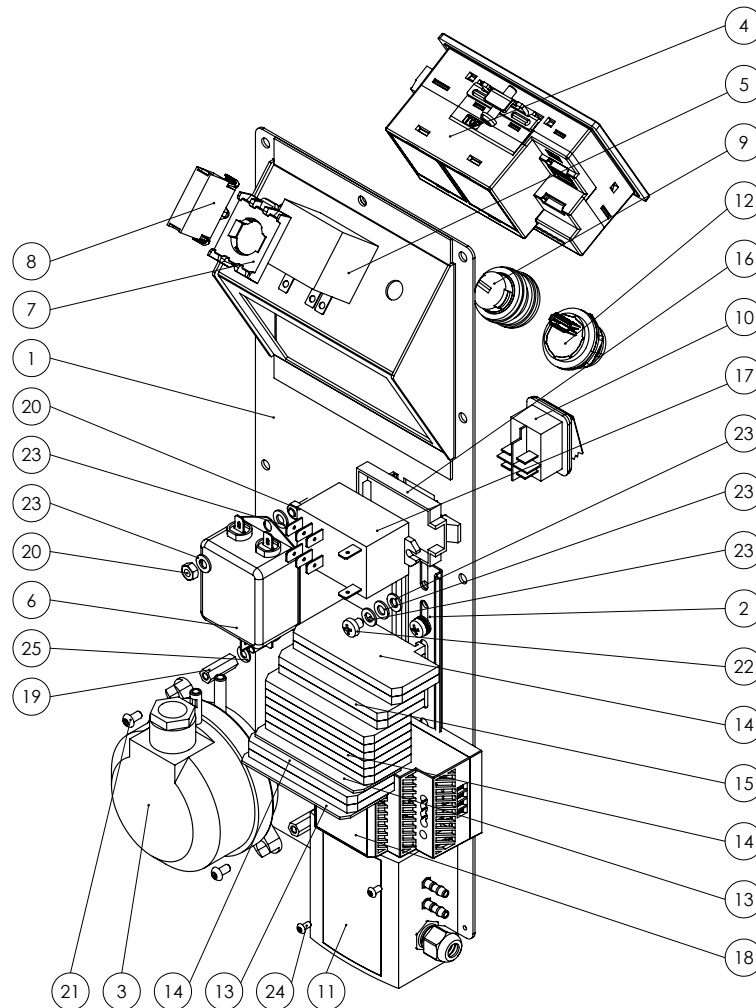

No.	Spare part	No.	Spare part
1	IDEC control unit (T0001376)	14	Feed-through terminal (FRK 2.5/4A BG (beige))
2	DIN rail (L=150)	15	Feed-through terminal (FSL 2,5/4A GNYE)
3	Differential pressure controller (DDW/H50 200Pa- 1000Pa)	16	Mounting clip (mounting clip for relay series 66)
4	Control system (PLC IDEC Touch compact FT1A-M14SAB)	17	Relay (power 30A 2 changeover contacts)
5	Temperature limiter (STB, 50..300°C (S) L=2000mm)	18	Power supply unit (HDR-60-24)
6	Mains filter (1PH 250VAC 16A 0.65mH FN2020-16-06)	19	Spacer sleeve (M04 x 20 IG/IG)
7	Mounting adapter (M22-A)	20	Hexagon nut (DIN 934 M5 VZ galv.)
8	LED element (M22-FLED-RGB)	21	Screw (Liko cross, DIN7380-1 M4x8 VZ galv.)
9	Indicator unit (M22-L-W WH)	22	Screw (Liko cross, DIN7985 M5x6 VZ)
10	Rocker switch (green, IP65 6.3 B4MASK N1E 21)	23	Washer (DIN 125 – A Ø5.3xØ10x1 VZ)
11	Pressure sensor (SPS-G-2KO)	24	Screw (Liko cross, DIN7380-1 M3x6 VZ)
12	USB Socket (USB Hous. Ex. 30cm A-W to A-M)	25	Washer (DIN 125 – A Ø4.3xØ9x0.8 VZ galv.)
13	End plate (FAP 2.5/4A YE)		

Heating



Info

The position numbers of the spare parts differ from those describing the positions of the components mentioned in these instructions.

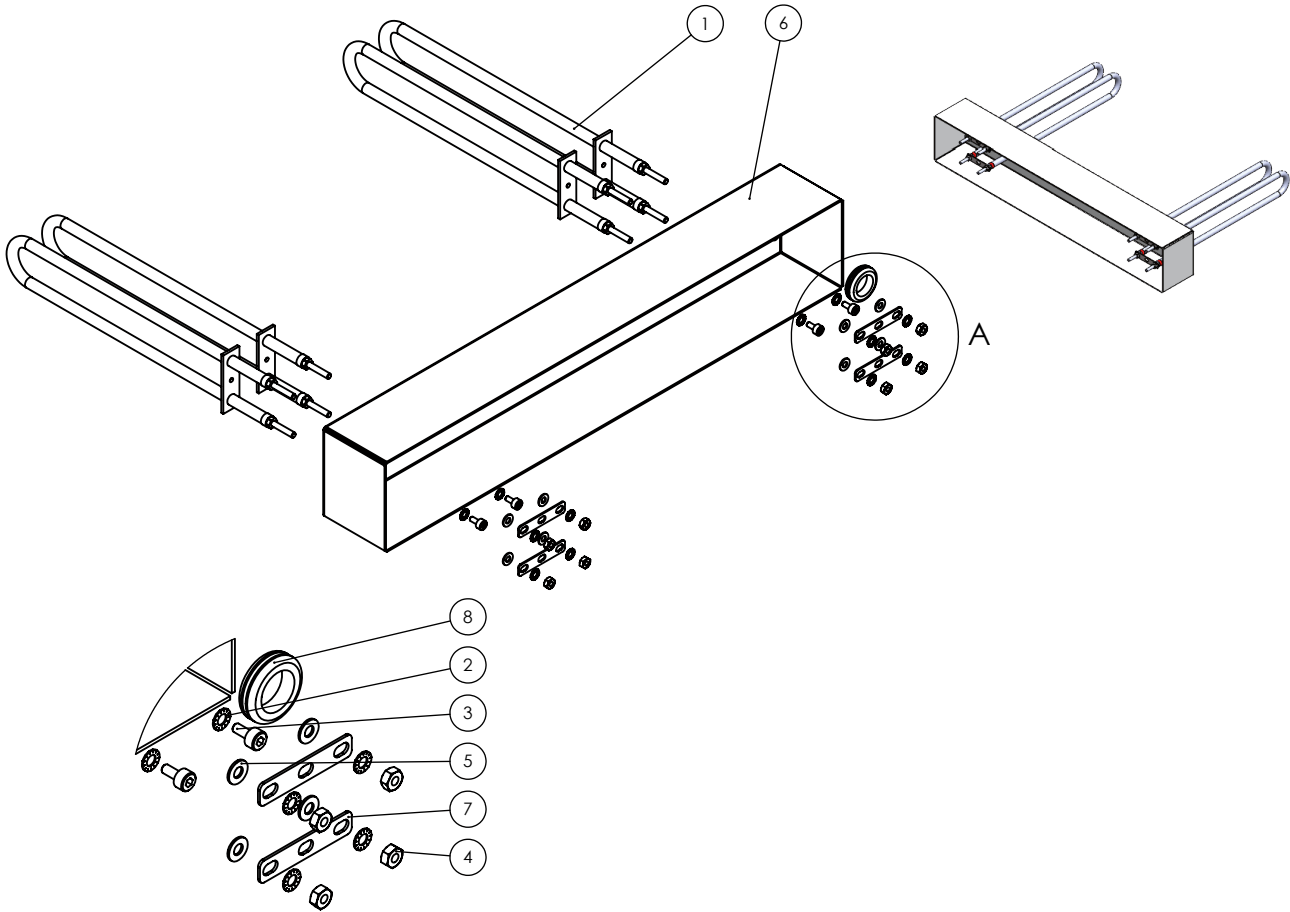

No.	Spare part	No.	Spare part
1	Heating rod (tubular heating element 277V 450W)	7	Washer (DIN 125 – A Ø4.3xØ9x0.8 VZ galv.)
2	Serrated lock washer (fan Ø4.3xØ8x0.5 VZ galv.)	8	Heating cover (T0001349)
3	Screw (cylinder Allen DIN 912 M4x8 VZ galv.)	9	Clamping bridge (Clamping bridge)
4	Hexagon nut (DIN 934 M4 VZ)	10	Sealing plug (Ø25.5xØ19xØ16x1.5x7, black)

Foot



Info

The position numbers of the spare parts differ from those describing the positions of the components mentioned in these instructions.

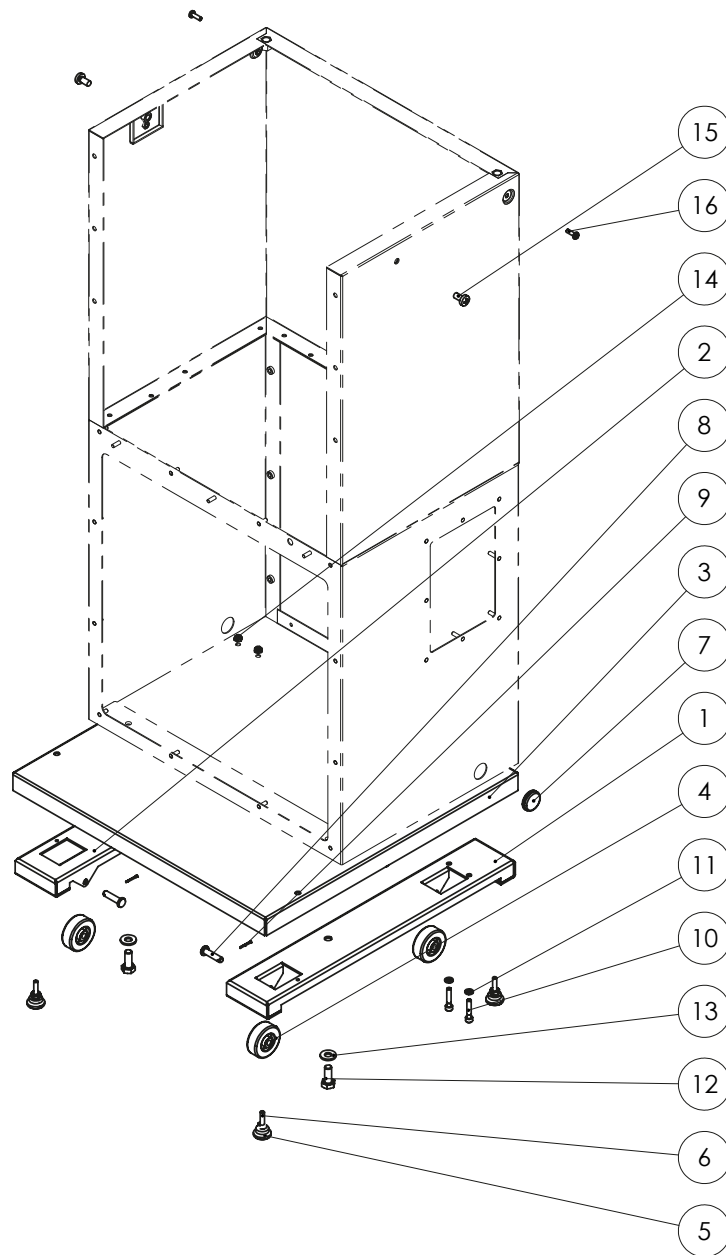

No.	Spare part	No.	Spare part
1	Wheel holder (T0001460)	9	Split pin (2 x 16 galvanised steel)
2	Wheel holder (T0001529)	10	Cylinder Allen screw (DIN 912 M6x30 VZ galv.)
3	Bottom plate (T0000886)	11	Washer (DIN 125 – A Ø6.4xØ12x1.6 VZ galv.)
4	Wheel (plain bearing wheel Ø50/18, wheel solid rubber grey, axis Ø8, 40kg)	12	Hexagon screw (DIN 933 M10x25 VZ galv.)
5	Hinged foot (threaded bushing, M6, galvanised steel / plastic foot)	13	Detent-edged washer (Ø10.2 x Ø22.3 x 2.5 VZ galv.)
6	Setscrew (M 6x30 VZ galv.)	14	Hexagon nut (self-locking, DIN 985 – M6 VZ galv.)
7	Sealing plug (Ø30xØ25.5xØ20.5x1.5x8, black)	15	Screw (Liko cross, DIN7985 M8x16 VZ galv., black)
8	Pin with head (DIN 1444 Ø8 x 29 x Ø2)	16	Screw (Liko cross, DIN7985 M5x16 VZ galv., black)

Tower, basalt grey



Info

The position numbers of the spare parts differ from those describing the positions of the components mentioned in these instructions.

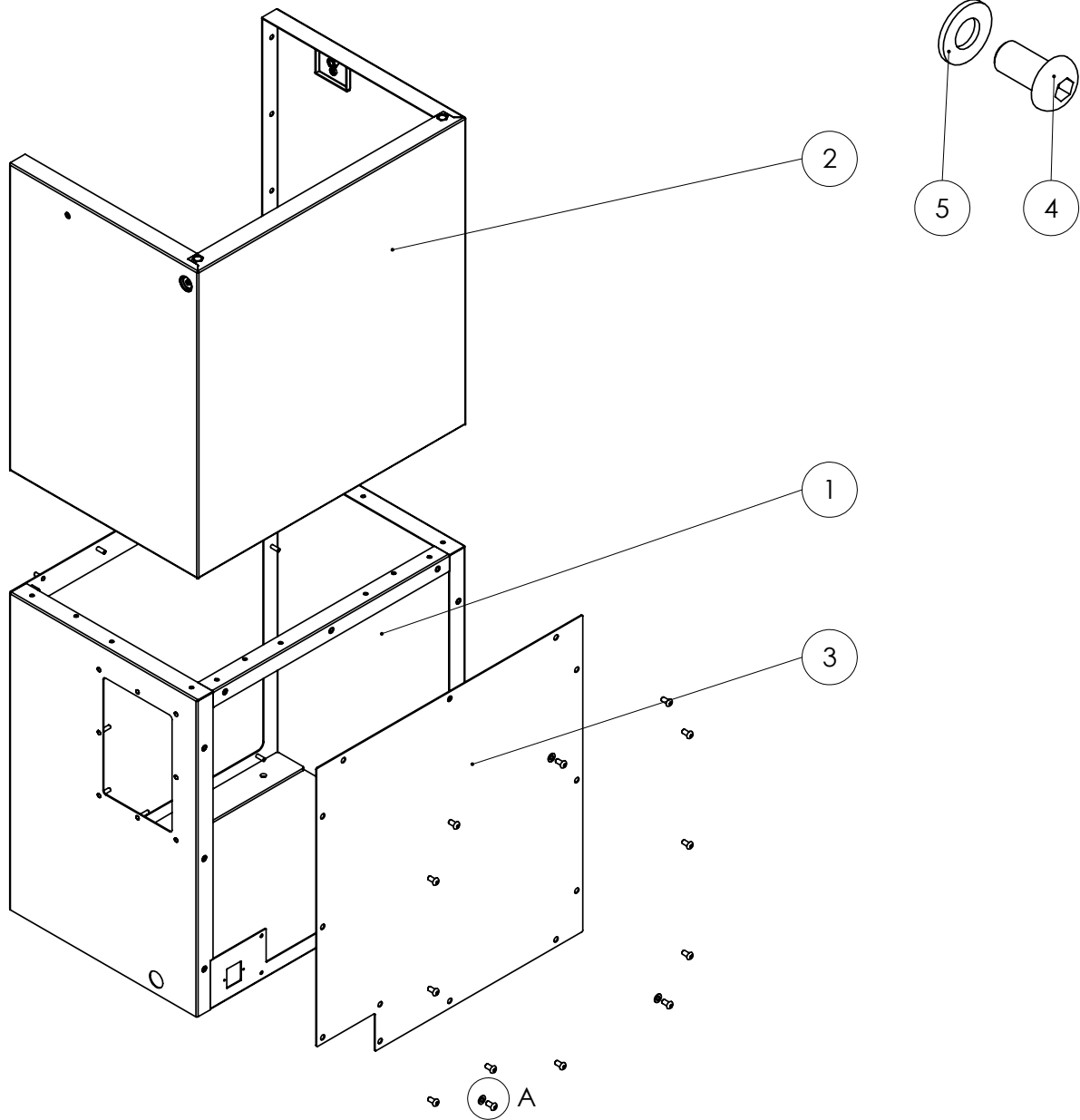

No.	Spare part	No.	Spare part
1	Bottom housing (T0000665)	4	Allen screw (Liko DIN7380-1 M6x12 VZ galv., black)
2	Upper housing (T0000746)	5	Detent-edged washer (Ø6 x Ø12.2 x 1.2 VZ galv.)
3	Cover for maintenance work (T0000711)		

Discharge hood



Info

The position numbers of the spare parts differ from those describing the positions of the components mentioned in these instructions.

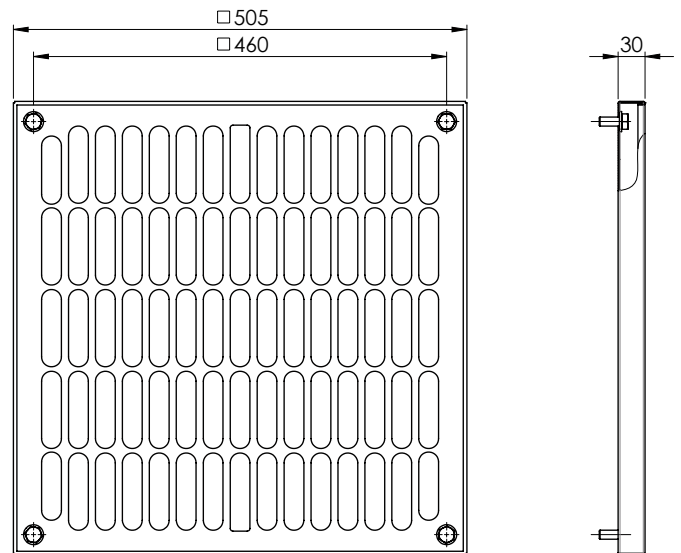
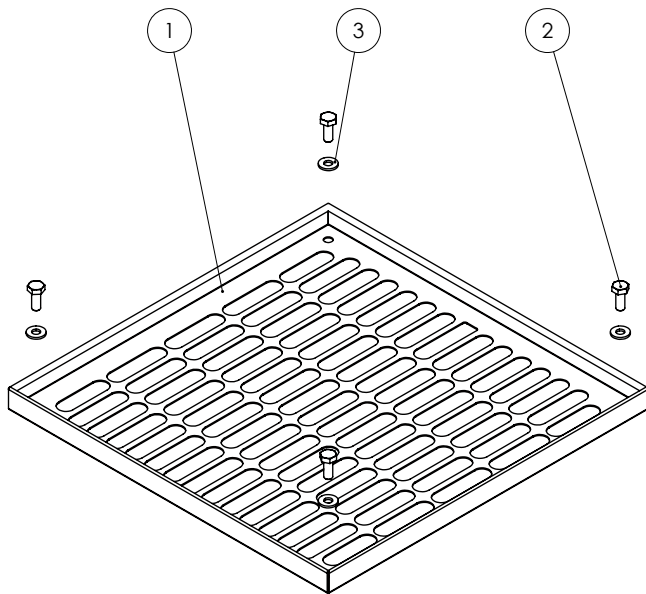

No.	Spare part	No.	Spare part
1	Hood (T0000737)	3	Detent-edged washer (Ø10.2 x Ø22.3 x 2.5 VZ galv.)
2	Hexagon screw (DIN 933 M10x25 VZ galv.)		

Air flap cover



Info

The position numbers of the spare parts differ from those describing the positions of the components mentioned in these instructions.

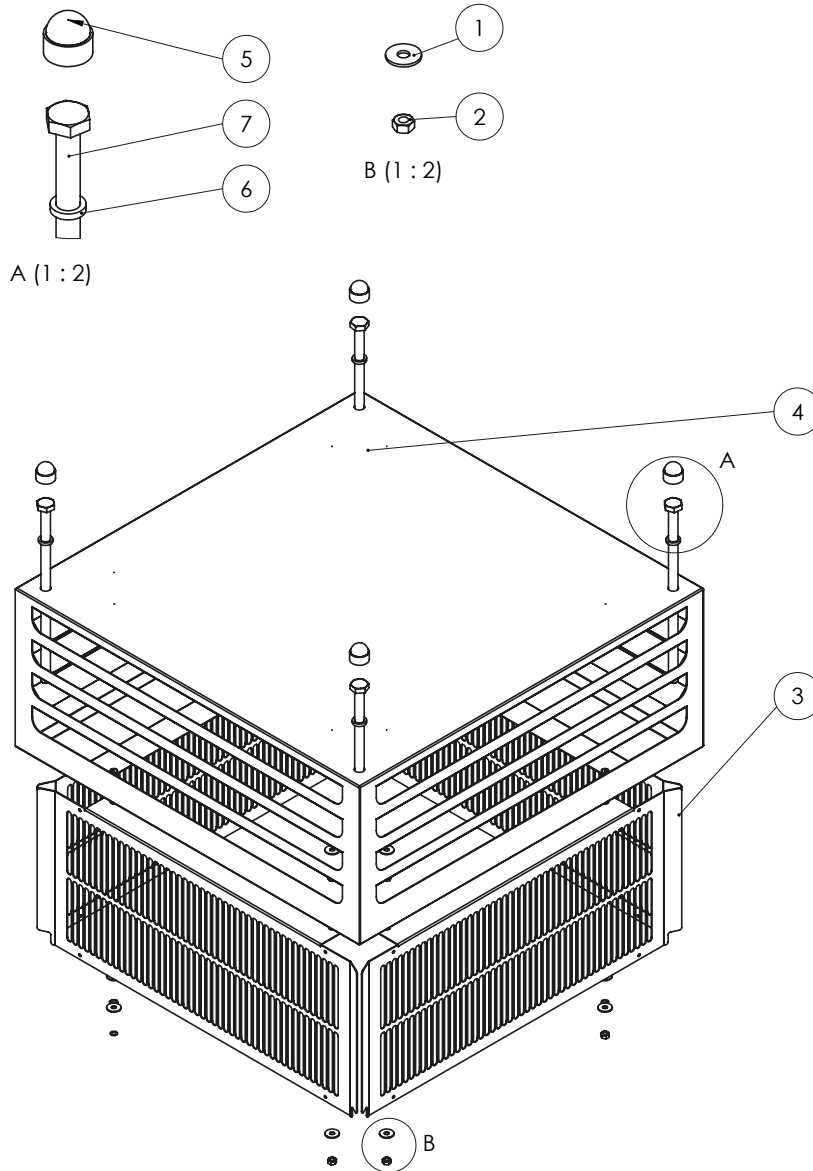

No.	Spare part	No.	Spare part
1	Washer (DIN 9021 Ø5.3xØ15x1.2 VZ galv)	5	Protective cap (M10 SW17 plastics, black)
2	Hexagon nut (DIN 934 M5 VZ galv.)	6	Washer (Ø10.3xØ15x3 white)
3	Protective plate (protective plate)	7	Hexagon screw (DIN 931 M10x220 VZ)
4	Air flap cover (air flap cover)		

Filter box



Info

The position numbers of the spare parts differ from those describing the positions of the components mentioned in these instructions.

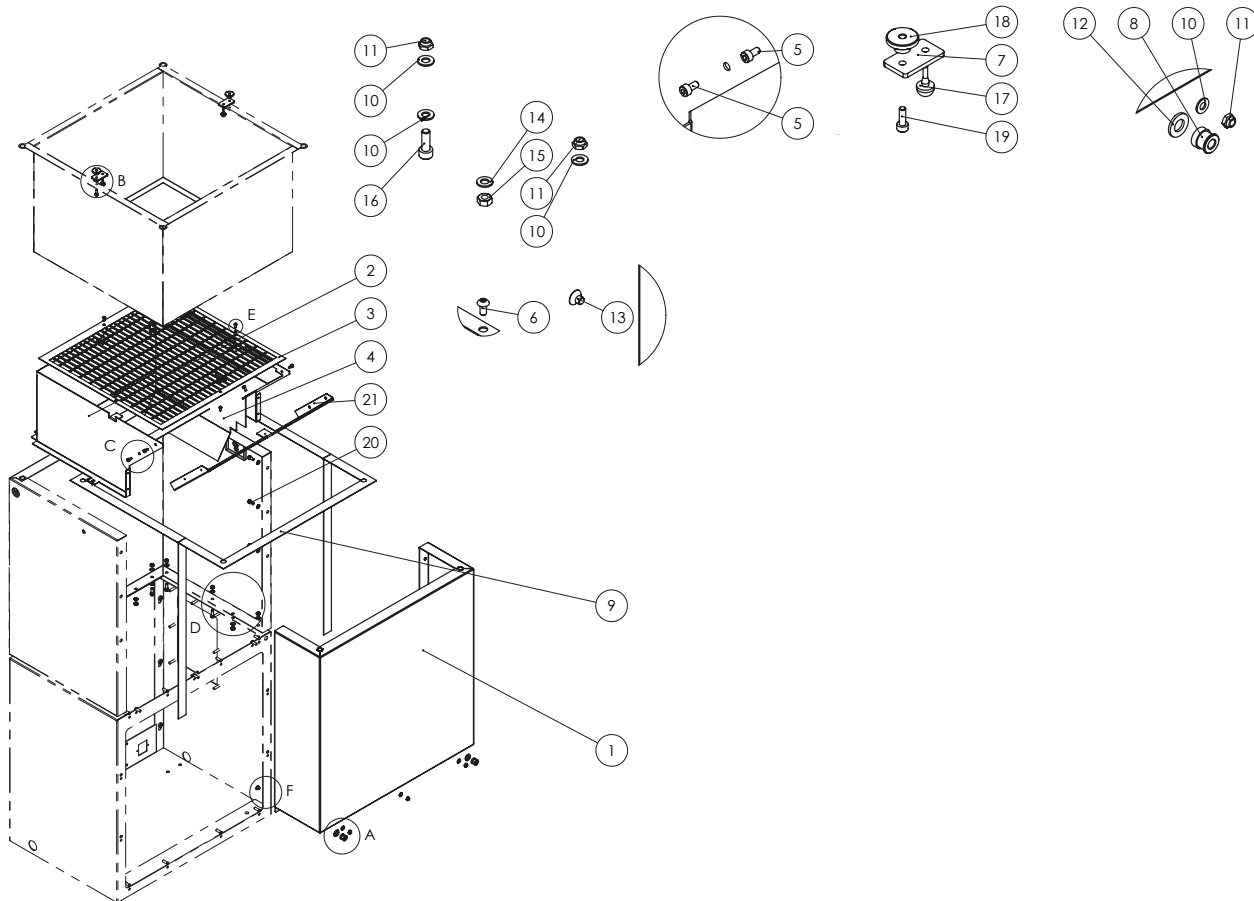

No.	Spare part	No.	Spare part
1	Front panel (T0000731)	12	Washer (DIN 125 – A Ø8.4xØ16x1.6 VZ galv.)
2	Heating mantle (T0001344)	13	Hexagon socket countersunk screw (DIN 7991 M 5x6 VZ galv.)
3	Finger protection (T0001343)	14	Washer (DIN 125 – A Ø5.3xØ10x1 VZ)
4	Heat shield plate (T0001352)	15	Hexagon nut (DIN 934 M5 VZ galv.)
5	Screw (cylinder Allen DIN 912 M4x8 VZ galv.)	16	Screw (cylinder Allen DIN 912 M5x14 VZ galv.)
6	Screw (Liko cross, DIN7380-1 M4x8 VZ galv.)	17	Rubber buffer (soft buffer 11 mm for 3.2 bore)
7	Hold-down device (T0000437)	18	Knurled nut (M4 black Ø20x9.5mm)
8	Locking sleeve (snap lock lower part M5)	19	Screw (cylinder Allen DIN 912 M4x12 VZ galv.)
9	Self-adhesive needle felt (25x1mm L=2920mm)	20	Screw (cylinder Allen DIN 912 M5x10 VZ galv.)
10	Detent-edged washer (Ø5.1 x Ø10.2 x 1 VZ galv.)	21	Connecting plate heating mantle (T0001346)
11	Hexagon nut (self-locking, DIN 985 – M5 VZ galv.)		

Fan box



Info

The position numbers of the spare parts differ from those describing the positions of the components mentioned in these instructions.

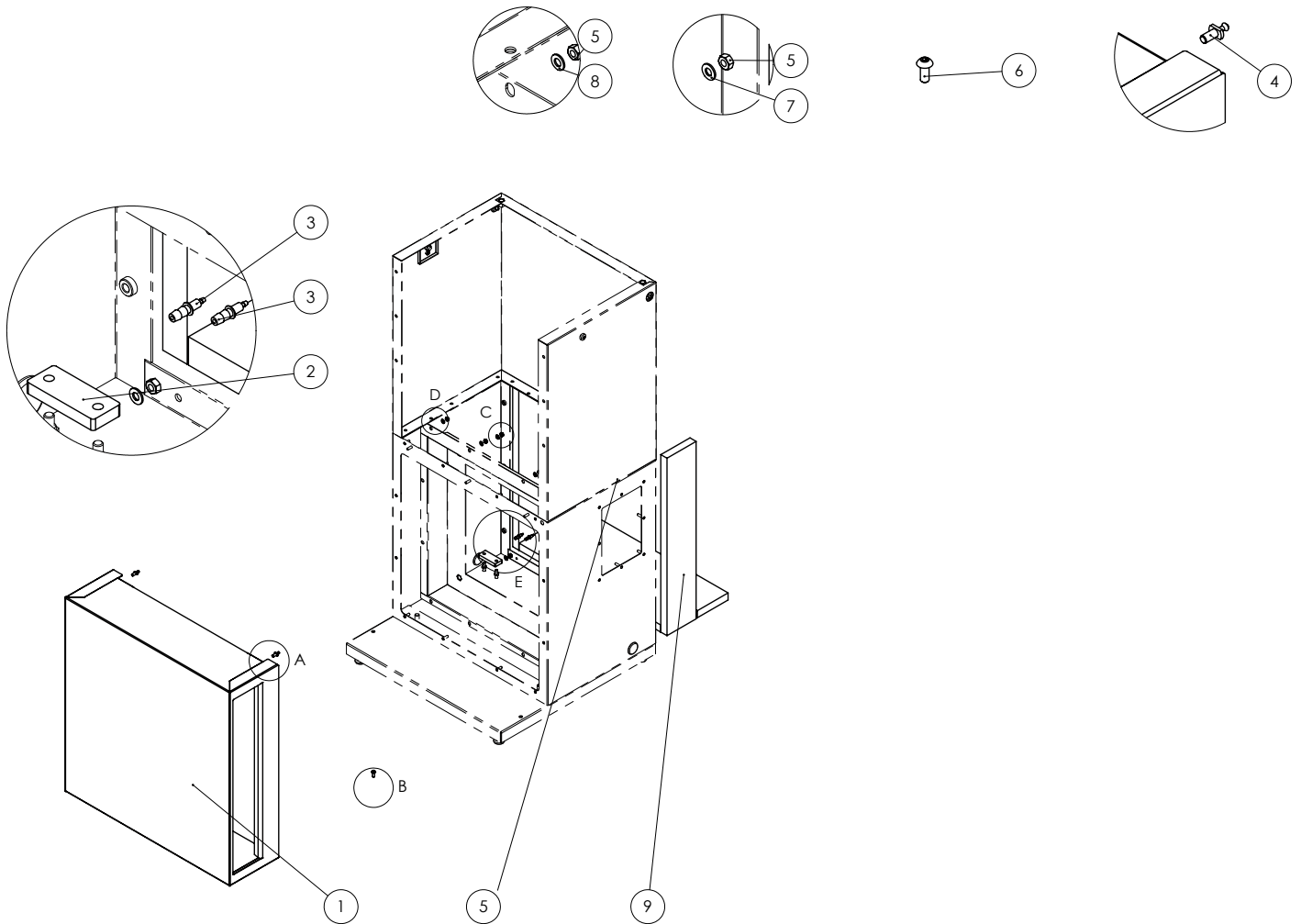

No.	Spare part	No.	Spare part
1	Silencer (T0000706)	6	Allen screw (Liko DIN7380-1 M5x12 VZ galv., black)
2	Support plate (T0000553)	7	Detent-edged washer (Ø5.1 x Ø10.2 x 1 VZ galv.)
3	Double hose connector (T0000370)	8	Washer (DIN 125 – A Ø5.3xØ10x1 VZ)
4	Closure plug (retaining bolt M5)	9	Insulation lower part (0001364)
5	Hexagon nut (DIN 934 M5 VZ galv.)		

Fan



Info

The position numbers of the spare parts differ from those describing the positions of the components mentioned in these instructions.

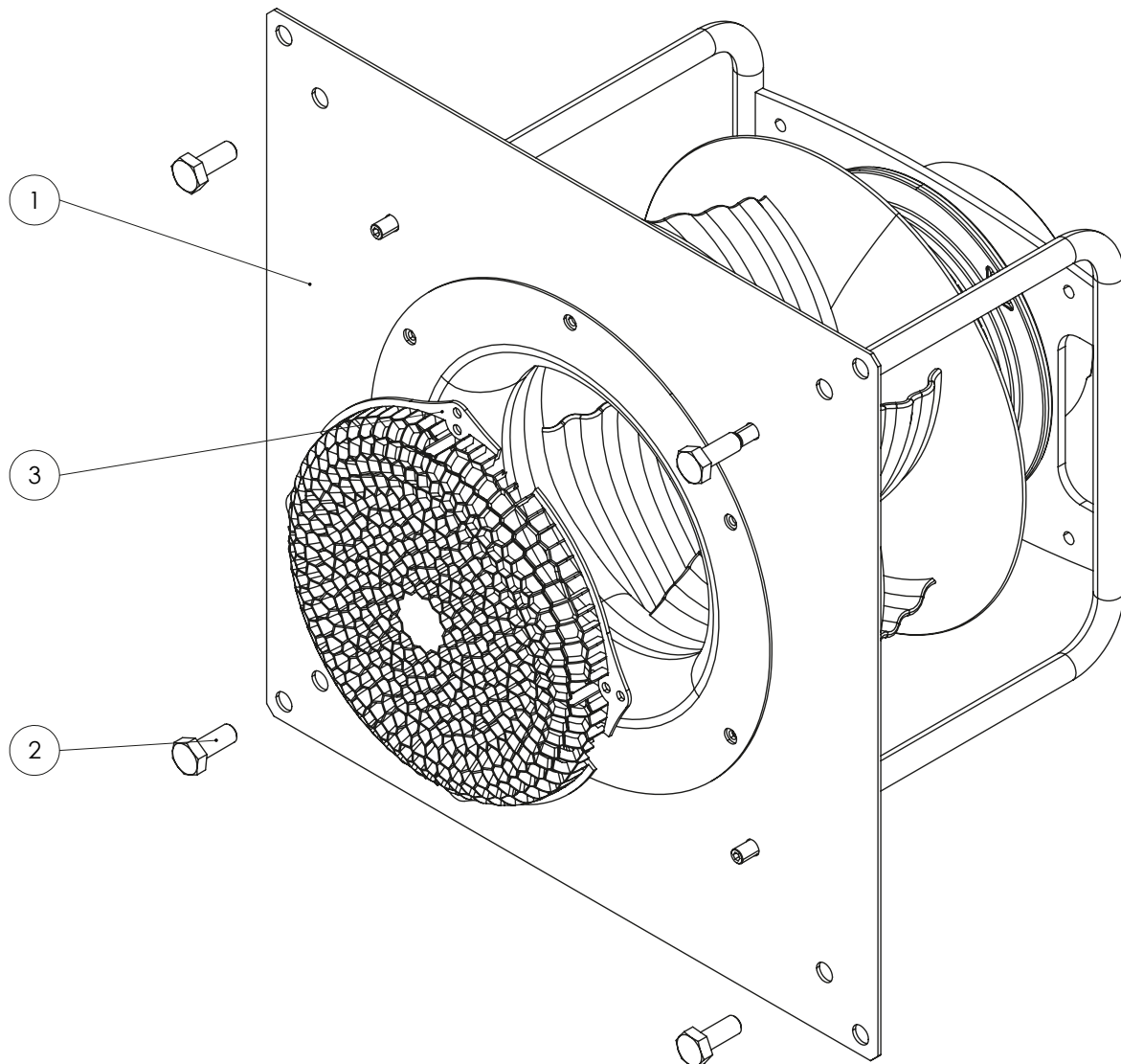

No.	Spare part	No.	Spare part
1	Fan (fan TAC V+)	3	Protective grid (bolt circle 206.6 or 226.6mm hole 5.4mm, black plastic)
2	Hexagon screw (DIN 933 M10x25 VZ galv.)		

Disposal

Always dispose of packing materials in an environmentally friendly manner and in accordance with the applicable local disposal regulations.



The icon with the crossed-out waste bin on waste electrical or electronic equipment stipulates that this equipment must not be disposed of with the household waste at the end of its life. You will find collection points for free return of waste electrical and electronic equipment in your vicinity. The addresses can be obtained from your municipality or local administration. You can also find out about other return options that apply for many EU countries on the website <https://hub.trotec.com/?id=45090>. Otherwise, please contact an official recycling centre for electronic and electrical equipment authorised for your country.

The separate collection of waste electrical and electronic equipment aims to enable the re-use, recycling and other forms of recovery of waste equipment as well as to prevent negative effects for the environment and human health caused by the disposal of hazardous substances potentially contained in the equipment.

Only for United Kingdom

According to Waste Electrical and Electronic Equipment Regulations 2013 (2013/3113) devices that are no longer usable must be collected separately and disposed of in an environmentally friendly manner.

Declaration of conformity

Declaration of conformity in accordance with the EC Machinery Directive 2006/42/EC, Annex II, Part 1, Section A

We – Trotec GmbH – declare in sole responsibility that the product designated below was developed, constructed and produced in compliance with the requirements of the EC Machinery Directive in the version 2006/42/EC.

Product model / product: TAC V+ Tower
TAC M Tower

Product type: high-performance air purifier

Year of manufacture as of: 2021

Relevant EU directives:

- 2011/65/EU: 01/07/2011
- 2014/30/EU: 29/03/2014

Applied harmonised standards:

- EN ISO 12100:2010
- EN ISO 13849-1:2015
- EN ISO 13857:2008
- EN ISO 14118:2018
- EN 55011:2009
- EN 60204-1:2018
- EN 60335-1:2012 + A13:2017
- EN 60335-2-30:2009 + A11:2012
- EN 60335-2-65:2003
- EN 61000-6-1:2007
- EN 61000-6-3:2007+A11:2011+AC:2012

Applied national standards and technical specifications:

- None

Manufacturer and name of the authorised representative of the technical documentation:

Trotec GmbH
Grebbeener Straße 7, D-52525 Heinsberg
Phone: +49 2452 962-400
E-mail: info@trotec.de

Place and date of issue:

Heinsberg, 02.07.2021

Detlef von der Lieck, Managing Director

Trotec GmbH

Grebener Str. 7
D-52525 Heinsberg

☎ +49 2452 962-400

☎ +49 2452 962-200

✉ info@trotec.com

www.trotec.com