

# AIRGOCLEAN® 170 + / AIRGOCLEAN® 171 E

**EN**

**INSTRUCTIONS**  
AIR CLEANER



**Table of contents**

**Information on the use of these instructions** ..... 2

**Safety** ..... 2

**Information about the device**..... 4

**Transport and storage**..... 5

**Assembly and start-up** ..... 5

**Operation** ..... 6

**Available accessories**..... 7

**Errors and faults** ..... 8

**Maintenance** ..... 9

**Technical annex**..... 13

**Disposal** ..... 13

**Information on the use of these instructions**

**Symbols**

 **Warning of electrical voltage**  
This symbol indicates dangers to the life and health of persons due to electrical voltage.

 **Warning**  
This signal word indicates a hazard with an average risk level which, if not avoided, can result in serious injury or death.

 **Caution**  
This signal word indicates a hazard with a low risk level which, if not avoided, can result in minor or moderate injury.

**Notice**  
This signal word indicates important information (e.g. material damage), but does not indicate hazards.

 **Info**  
Information marked with this symbol helps you to carry out your tasks quickly and safely.

 **Follow the manual**  
Information marked with this symbol indicates that the instructions must be observed.

You can download the current version of the instructions and the EU declaration of conformity via the following link:

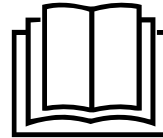

AirgoClean® 170 +



<https://hub.trotec.com/?id=47534>

AirgoClean® 171 E



<https://hub.trotec.com/?id=44804>

**Safety**

**Read this manual carefully before starting or using the device. Always store the manual in the immediate vicinity of the device or its site of use.**

-  **Warning**  
**Read all safety warnings and all instructions.** Failure to follow the warnings and instructions may result in electric shock, fire and/or serious injury. **Save all warnings and instructions for future reference.**
- This appliance can be used by children aged from 8 years and above and persons with reduced physical, sensory or mental capabilities or lack of experience and knowledge if they have been given supervision or instruction concerning use of the appliance in a safe way and understand the hazards involved. Children shall not play with the appliance. Cleaning and user maintenance shall not be made by children without supervision.
- Do not use the device in potentially explosive rooms or areas and do not install it there.
  - Do not use the device in aggressive atmosphere.
  - Do not operate the device near open fire or gas appliances.
  - Place the device in an upright and stable position on horizontal and stable ground.
  - Let the device dry out after a wet clean. Do not operate it when wet.
  - Do not use the device with wet or damp hands.
  - Do not expose the device to directly squirting water.
  - Do not expose the device to liquids as it is not protected against splash water.

- Never insert any objects or limbs into the device.
- Do not cover the device during operation.
- Do not sit on the device.
- This appliance is not a toy. Keep away from children and animals. Do not leave the device unattended during operation.
- Check accessories and connection parts for possible damage prior to every use of the device. Do not use any defective devices or device parts.
- Ensure that all electric cables outside of the device are protected from damage (e.g. caused by animals). Never use the device if electric cables or the power connection are damaged!
- The mains connection must correspond to the specifications in the Technical annex.
- Insert the mains plug into a properly fused mains socket.
- Observe the technical data when selecting extensions to the power cable. Completely unroll the extension cable. Avoid electrical overload.
- Before carrying out maintenance, care or repair work on the device, remove the mains plug from the mains socket. Hold onto the mains plug while doing so.
- Switch the device off and disconnect the power cable from the mains socket when the device is not in use.
- Do not under any circumstances use the device if you detect damages on the mains plug or power cable. If the power cable is damaged, it must be replaced by the manufacturer, its service agent or similarly qualified persons in order to avoid a hazard. Defective power cables pose a serious health risk!
- When positioning the device, observe the minimum distances from walls and other objects as well as the storage and operating conditions specified in the Technical annex.
- Make sure that the air inlet and outlet are not obstructed.
- Make sure that there are no loose items or dirt located in the immediate surroundings of air inlet and air outlet.
- Do not remove any safety signs, stickers or labels from the device. Keep all safety signs, stickers and labels in legible condition.
- Do not expose the device to heat or direct sunlight.
- Make sure that the suction side is kept free of dirt and loose objects.
- Dispose of replaced filters properly.
- Never use the device as storage place or footstep.
- Do not use the automatic mode if the device is used for virus filtration.

## Intended use

Use the device for cleaning the air in interior spaces only whilst adhering to the technical data and safety instructions.

Any use other than the intended use is regarded as misuse.

## Reasonably foreseeable misuse

- Do not place the device on wet or flooded ground.
- Do not place any objects, e.g. clothing, on the device.
- Do not use the device out of doors.
- Do not use the device in bathrooms and rooms with a high humidity level.
- Do not use the device in rooms where large amounts of dust are produced, e.g. in production halls, workshops or on construction sites.
- Moreover, the integrated filter system is not suited for removing dusts that are potentially harmful to health (e.g. pollutants) from the air.
- Do not make any unauthorised modifications, alterations or structural changes to the device.

## Personnel qualification

People who use this device must:

- be aware of the dangers that occur when working with electrically driven air cleaners.
- have read and understood the instructions, especially the Safety chapter.

## Residual risks



### Warning of electrical voltage

Work on the electrical components must only be carried out by an authorised specialist company!



### Warning of electrical voltage

Before any work on the device, remove the mains plug from the mains socket!  
Do not touch the mains plug with wet or damp hands. Hold onto the mains plug while pulling the power cable out of the mains socket.



### Warning

Dangers can occur at the device when it is used by untrained people in an unprofessional or improper way! Observe the personnel qualifications!



### Warning

The device is not a toy and does not belong in the hands of children.



### Warning

Risk of suffocation!  
Do not leave the packaging lying around. Children may use it as a dangerous toy.

**Notice**

Do not operate the device without a HEPA carbon filter inserted!

**Notice**

Do not operate the device without an air filter inserted into the air inlet!

Without the air filter, the inside of the device will be heavily contaminated. This can reduce the performance and result in damage to the device.

**Notice**

Do not use abrasive cleaners or solvents to clean the device.

**Behaviour in the event of an emergency**

1. Switch the device off.
2. Disconnect the device from the mains: Hold onto the mains plug while pulling the power cable out of the mains socket.
3. Do not reconnect a defective device to the mains.

**Information about the device**

**Device description**

The device serves to filter the room air with the aim of reducing slight and medium contaminations and odours in order to improve the air quality. It is equipped with a powerful fan sucking in the air. The air flows through the filter and is cleaned. Afterwards the fan releases the clean air back into the room.

The 3-in-1 filter is composed of a HEPA filter, a carbon filter and a prefilter.

The device uses a HEPA filter to remove bacteria, viruses, pollen, dust mite residue, mould fungus spores and other allergens from the air. The integrated prefilter (made of synthetic fibre) filters out large dust particles before the air flows into the HEPA filter. The integrated carbon filter with activated carbon also removes odours from the air.

The HEPA carbon filter is effective against house dust, pet allergens, cigarette smoke, smog and particles which can carry smells and viruses.

The device is equipped with an air quality sensor to display the air quality and control air purification automatically.

The five-stage fan and the uncomplicated, quick filter change ensure easy operation.

Thanks to its compact dimensions the device can be transported conveniently, and owing to its low-noise operation it can be used indoors.

The device has a control panel for operating and controlling the functions.

The devices are structurally identical. They merely differ in colour. The device AirgoClean 170 + comes in white colour, the AirgoClean 171 E is black. Both devices have a HEPA carbon filter with a filter efficiency of 99.97 %.

**Device depiction**

**Front**

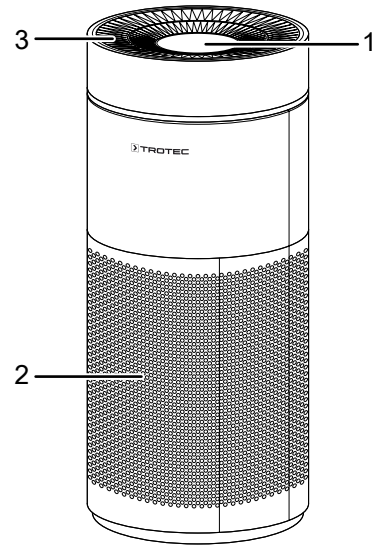

**Rear**

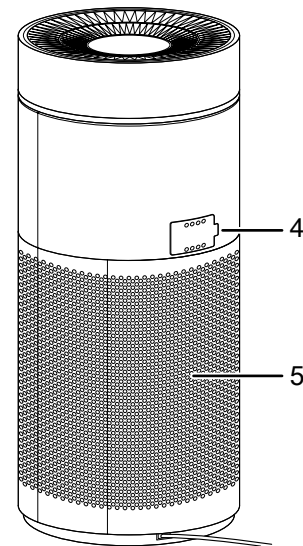

No.	Designation
1	Control panel
2	Air inlet with HEPA carbon filter
3	Air outlet
4	Air quality sensor
5	Device cover

## Transport and storage

### Notice

If you store or transport the device improperly, the device may be damaged.

Note the information regarding transport and storage of the device.

### Transport

**Before** transporting the device, observe the following:

- Switch the device off.
- Hold onto the mains plug while pulling the power cable out of the mains socket.
- Do not use the power cable to drag the device.

**After** transporting the device, proceed as follows:

- Set up the device in an upright position after transport.

### Storage

When the device is not being used, observe the following storage conditions:

- Store the device in a dry location and protected from frost and heat.
- Store the device in an upright position where it is protected from dust and direct sunlight.
- If required, use a cover to protect the device from invasive dust.

## Assembly and start-up

### Scope of delivery

- 1 x Device
- 1 x HEPA carbon filter
- 1 x Manual

### Unpacking the device

1. Open the cardboard box and take the device out.
2. Completely remove the packaging.
3. Fully unwind the power cable. Make sure that the power cable is not damaged and that you do not damage it during unwinding.

### Start-up

The HEPA carbon filter is pre-installed.

### Notice

Remove the plastic cover from the HEPA carbon filter. To insert the HEPA carbon filter, proceed as described under Changing the HEPA carbon filter.

When positioning the device, observe the minimum distance from walls or other objects as described in the chapter Technical annex.

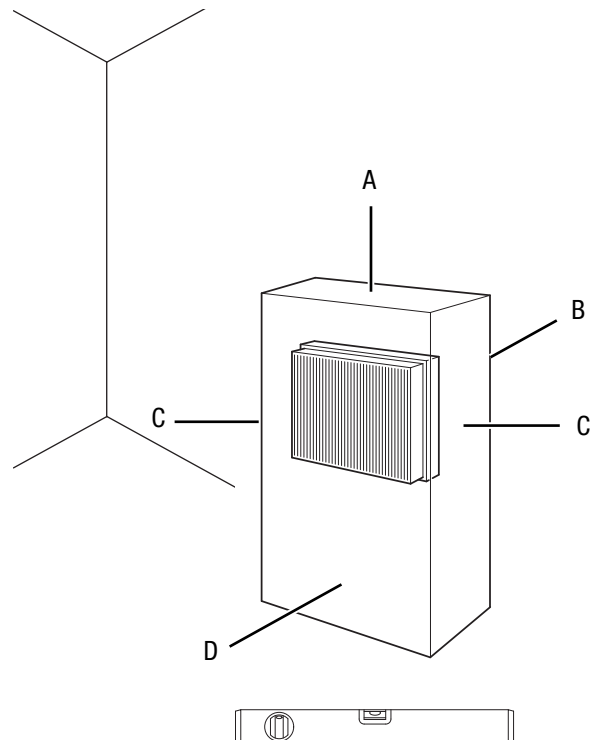

- Before restarting the device, check the condition of the power cable. If there are doubts as to the sound condition, contact the customer service.
- Place the device in an upright and stable position on horizontal and stable ground.
- Do not create tripping hazards when laying the power cable or other electric cables, especially when positioning the device in the middle of the room. Use cable bridges.
- Make sure that extension cables are completely unrolled.
- Position the device near the source of air contamination.
- When positioning the device, keep a sufficient distance to heat sources.
- Make sure that no curtains or other objects interfere with the air flow.
- Make sure that the air inlet and outlet are not obstructed.

### Connecting the power cable

- Insert the mains plug into a properly fused mains socket.

**Operation**

**Notice**

Avoid open doors and windows.

**Control panel**

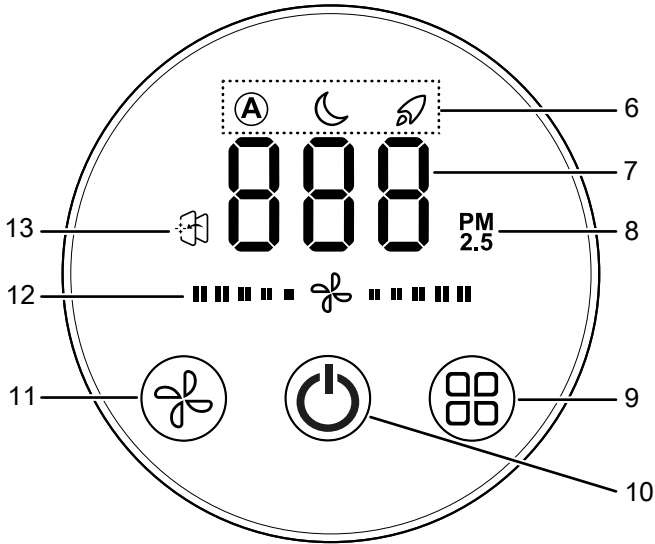

No.	Designation	Meaning
6	Operating mode LEDs	Indicates the selected operating mode: Ⓐ = automatic mode ☾ = night mode 🌀 = turbo mode
7	Segment display	Indicates the measured air quality
8	Air quality LED	Is illuminated according to the air quality: green = good blue = medium red = poor
9	Operating mode button	Selecting the operating mode
10	Power button	For switching the device on and off
11	Fan speed button	Setting the fan speed in 5 stages
12	Fan speed LED	Indication of the selected fan speed
13	Filter change LED	Illuminated when the filter needs to be changed

**Switching the device on**

Once you have completely installed the device as described in the Start-up chapter, you can switch it on. When the power cable has been connected, the control panel lights up for 2 seconds and an acoustic signal is emitted. Afterwards, only the *Power* button (10) is illuminated in red and the device is in standby mode.

Please proceed as follows to switch the device on:

1. Press the *Power* button (10).
  - ⇒ The *Power* button (10) is illuminated in white.
  - ⇒ The device is switched on and starts operating in automatic mode. The corresponding operating mode LED (6) will be illuminated.
  - ⇒ The device measures the air quality within 3 minutes. The *air quality* LED (8) is illuminated. The air quality will be indicated on the segment display (7).

If no operational input is made for approx. 40 seconds, the brightness of the control panel decreases. The full brightness will be restored the next time you make an entry.

**Setting the operating mode**

The device comes with the following operating modes:

- Automatic mode
- Night mode
- Turbo mode

Please proceed as follows to switch between operating modes:

- ✓ The device is switched on.
- 1. Press the *operating mode* button (9).
  - ⇒ The corresponding *operating mode* LED (6) will be illuminated.

**Automatic mode**

Once you switch on the device, it starts in automatic mode. The corresponding *operating mode* LED (6) will be illuminated.

When in automatic mode, the device automatically detects the air quality.

The *air quality* LED (8) is illuminated accordingly in green, blue or red. The air quality will be indicated on the segment display (7).

The PM2.5 value will be indicated on the segment display (7) after the device has carried out the air quality measurement.

Air quality LED	Indication on the segment display	Fan speed LED
Illuminated in green (good air quality)	0 ~ 35	Stage 2
Illuminated in blue (medium air quality)	36 ~ 116	Stage 3 and 4
Illuminated in red (poor air quality)	> 116	Stage 4 and 5



## Info

### Automatic mode and virus filtration

Do not use the automatic mode if the device is used for virus filtration!

The integrated sensors only respond to air pollution caused by fine particulates, pollen or possibly VOC (organic chemical compounds). The device cannot determine the virus load inside the room. It is possible that the automatic mode indicates a "good air quality" even though the virus load in the room is very high. Therefore, when using the device for virus filtration, we recommend that you always select a fixed performance level adapted to the room size or the required circulation rate.

### Night mode

In *night* mode, the device generates an air current that is adapted to your sleep habits.

Proceed as follows to switch on night mode:

- ✓ Measuring the air quality is not activated and the *air quality* LED (8) is not illuminated.
- 1. Press the *operating mode* button (9).
  - ⇒ The device is running at the lowest fan stage. The *fan speed* LED (12) is not illuminated.
  - ⇒ The *night mode* LED (6) is illuminated.

If no operational input is made for approx. 40 seconds, the brightness of the control panel decreases.

### Turbo mode

When in turbo mode, the device automatically detects the air quality. The *air quality* LED (8) is illuminated and the air quality is indicated on the segment display (7).

Proceed as follows to switch on turbo mode:

- 1. Press the *operating mode* button (9).
  - ⇒ The device is running at the highest fan stage.
  - ⇒ The *fan speed* LED (12) is illuminated.

### Ventilation

In this mode you can select all 5 speeds manually.

Please proceed as follows to adjust the fan speed:

- ✓ The device is switched on.
- 1. Select the desired fan speed by pressing the *fan speed* button (11).
  - ⇒ The *fan speed* LED (12) of stage 1, 2, 3, 4 or 5 is illuminated.

### Memory function

If you switch the device back on from standby mode, the settings selected for the operating mode and fan speed are saved.

In the event of brief power failures or if the cover is opened, the device will **not** remember the settings. When switched on, the device will start in *automatic* mode in this case.

## Shutdown



### Warning of electrical voltage

Do not touch the mains plug with wet or damp hands.

- Switch off the device by pressing the *Power* button (10).
- Hold onto the mains plug while pulling the power cable out of the mains socket.
- Clean the device according to the Maintenance chapter.
- Store the device according to the Transport and storage chapter.

## Available accessories



### Warning

Only use accessories and additional equipment specified in the instructions. Using insertion tools or accessories other than those specified in the instructions may cause a risk of injury.

Designation	Article number
HEPA carbon filter (filter efficiency 99.7 %)	7.160.000.530
HEPA carbon filter (filter efficiency 99.97 %)	7.160.000.531

## Errors and faults

The device has been checked for proper functioning several times during production. If malfunctions occur nonetheless, check the device according to the following list.

### Notice

Wait for at least 3 minutes after maintenance and repair work. Only then switch the device back on.

### The device does not start:

- Check the power connection.
- Check the power cable and mains plug for damage.
- Check the on-site fusing.
- Check the device cover (5) for proper fit.

### The device is loud or vibrates:

- Check whether the device is set up in a stable and upright position.

### The device gets very warm, is loud or is losing power:

- Check the air inlets and air filters for dirt. Remove external dirt.

### The device works with reduced capacity:

- The air outlet is obstructed. Make sure that the air outlet is not blocked. Remove any loose objects from the air outlet.
- The HEPA carbon filter's plastic cover was not removed before installation. Take the HEPA carbon filter out of the plastic cover.

### The device works with no capacity or the air quality does not improve:

- Check whether any windows and/or doors of the room are open. If so, close them.
- The HEPA carbon filter is not installed. Install the HEPA carbon filter.
- Check the minimum distance to walls or other objects. Position the device a little more in the room's centre if required.

### The *air quality* LED is illuminated in red for a longer period of time:

- Check the air quality in the room. The air in the room may be heavily contaminated. Wait for a few minutes to see whether the colour of the *air quality* LED changes.
- The air quality sensor is clogged or soiled. Windows and doors should be closed, otherwise dust and other contamination is able to enter the room. Clean the air quality sensor as described in the Maintenance chapter.

### The device gives off an unpleasant odour:

- Check the HEPA carbon filter for dirt. If necessary, clean or replace the HEPA carbon filter.
- Smoke, e.g. dense tobacco smoke, odours and contaminations may be in the air. Ventilate the room.

### The *filter change* LED (13) flashes:

- Change the filter as described in the Maintenance chapter.

### The segment display (7) indicates L3, H8, H3 or ---:

- Please contact the customer service. If necessary, bring the device to an authorised specialist electrical company or to Trotec for repair.

### The device still does not operate correctly after these checks:

Please contact the customer service. If necessary, bring the device to an authorised specialist electrical company or to Trotec for repair.



## Maintenance

### Note

All service activities other than those specified in the maintenance table may only be performed by a specialist company authorized by Trotec.

### Maintenance intervals

Maintenance and care interval	before every start-up	as needed	at least every 2 weeks	at least every 4 weeks	at least every 6 months	at least annually
Check air inlets and outlets for dirt and foreign objects and clean if necessary	X			X		
Clean the exterior		X				X
Visually check the inside of the device for dirt		X				X
Check the filter for dirt and foreign objects and clean or replace if necessary	X		X			
Replace the filter					X	
Cleaning the air quality sensor		X				
Check for damage	X					
Check the attachment screws		X				X
Test run						X

### Maintenance and care log

Device type: .....

Device number: .....

Maintenance and care interval	1	2	3	4	5	6	7	8	9	10	11	12	13	14	15	16
Check air inlets and outlets for dirt and foreign objects and clean if necessary																
Clean the exterior																
Visually check the inside of the device for dirt																
Check the filter for dirt and foreign objects and clean or replace if necessary																
Replace the filter																
Cleaning the air quality sensor																
Check for damage																
Check the attachment screws																
Test run																

1. Date: ..... Signature: .....	2. Date: ..... Signature: .....	3. Date: ..... Signature: .....	4. Date: ..... Signature: .....
5. Date: ..... Signature: .....	6. Date: ..... Signature: .....	7. Date: ..... Signature: .....	8. Date: ..... Signature: .....
9. Date: ..... Signature: .....	10. Date: ..... Signature: .....	11. Date: ..... Signature: .....	12. Date: ..... Signature: .....
13. Date: ..... Signature: .....	14. Date: ..... Signature: .....	15. Date: ..... Signature: .....	16. Date: ..... Signature: .....

**Activities required before starting maintenance**



**Warning of electrical voltage**

Do not touch the mains plug with wet or damp hands.

- Switch the device off.
- Hold onto the mains plug while pulling the power cable out of the mains socket.



**Warning of electrical voltage**

**Tasks which require the device to be opened must only be carried out by authorised specialist companies or by Trotec.**

**Cleaning the housing**

Clean the housing with a soft, damp and lint-free cloth. Make sure that no moisture enters the housing. Protect electrical components from moisture. Do not use any aggressive cleaning agents such as cleaning sprays, solvents, alcohol-based or abrasive cleaners to dampen the cloth.

**Visual inspection of the inside of the device for dirt**

1. Remove the air filter.
2. Use a torch to illuminate the openings of the device.
3. Check the inside of the device for dirt.
4. If you see a thick layer of dust, clean the inside of the device with a vacuum cleaner.
5. Put the air filter back in.

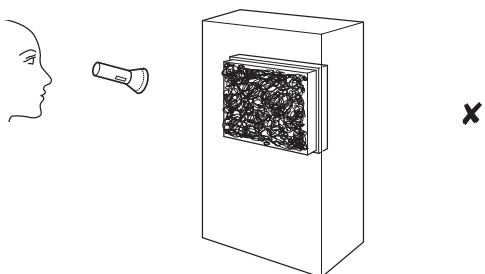
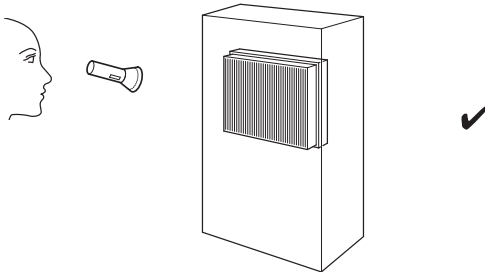

**Cleaning the device cover and HEPA carbon filter**

**Notice**

The HEPA carbon filter is not washable. Do not use water or liquid cleaning agents to clean the HEPA carbon filter.

1. Remove the cover (5) at the rear of the device using the notches.
2. Pull the strip (15) to take the HEPA carbon filter (14) out of the device.

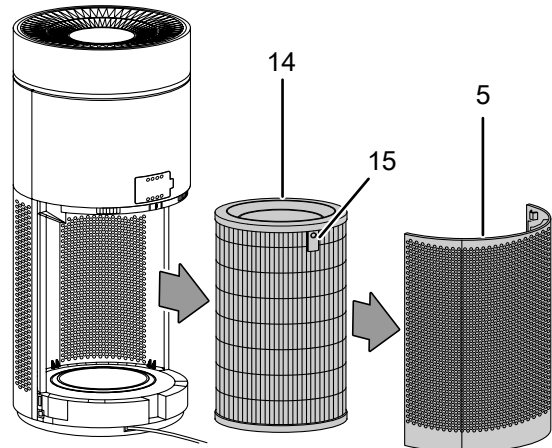

3. Clean the device cover and the inside of the air inlet with a soft brush or a soft, lint-free cloth.
4. Clean the outside of the HEPA carbon filter with a soft brush or a soft, lint-free cloth.
5. Reinsert the HEPA carbon filter into the device. Make sure that the strip of the filter is positioned on the outside. Slide the filter into the device until it is positioned flush with the notch at the bottom of the device.

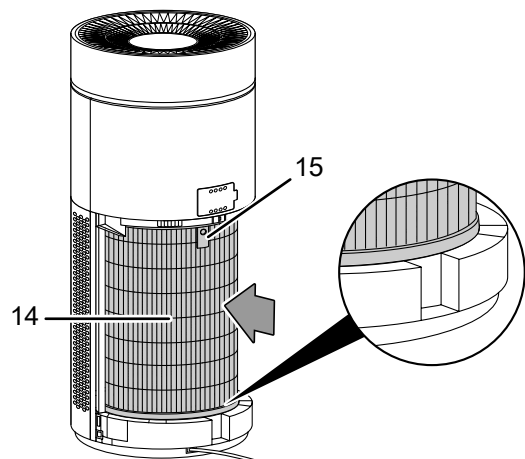

- Put the device cover back on the device. To do so, insert the lower hooks of the device cover into the corresponding notches of the device and then push the top of the cover onto the device. Make sure that the cover is fitted correctly.

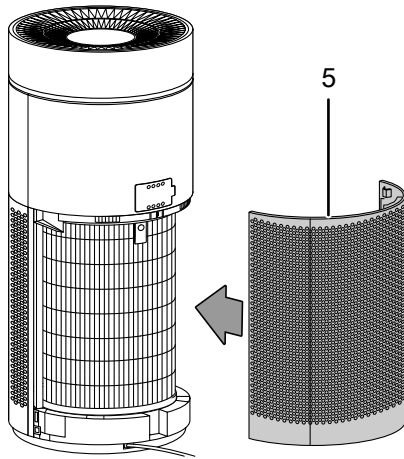

## Changing the HEPA carbon filter

### Notice

Do not operate the device without a HEPA carbon filter inserted!

### Notice

The HEPA carbon filter is not washable. Do not use water or liquid cleaning agents to clean the HEPA carbon filter.

- The HEPA carbon filter has to be replaced if the *filter change* LED (13) flashes or if the filter is dirty, which manifests itself e.g. through reduced capacity (see chapter Errors and faults).
- Make sure that the HEPA carbon filter is installed before switching the device on.
- Without the HEPA carbon filter, the device cannot fulfil its air cleaner function, and the inside of the device will be soiled.

The HEPA carbon filter should be replaced in case of heavy soiling.

The operating life of the HEPA carbon filter is approx. 6 months, depending on the degree of air pollution.

If required, visually inspect the HEPA carbon filter for dirt.

- Remove the rear device cover (5) from the device. To do so, grab it by the side notches.

- Pull the strip (15) to take the used HEPA carbon filter (14) out of the device.

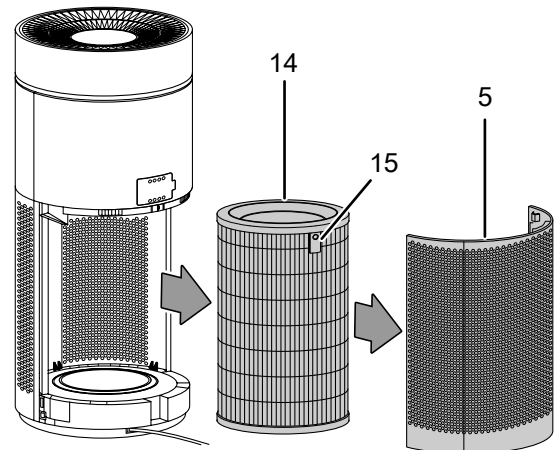

- Dispose of the used HEPA carbon filter according to the national regulations.
- Take the new HEPA carbon filter out of the plastic cover. The front of the HEPA carbon filter is fitted with a strip.
- Insert the new HEPA carbon filter into the device. Make sure that the strip of the filter is positioned on the outside. Push the filter into the device until it is positioned flush with the notch at the bottom of the device.

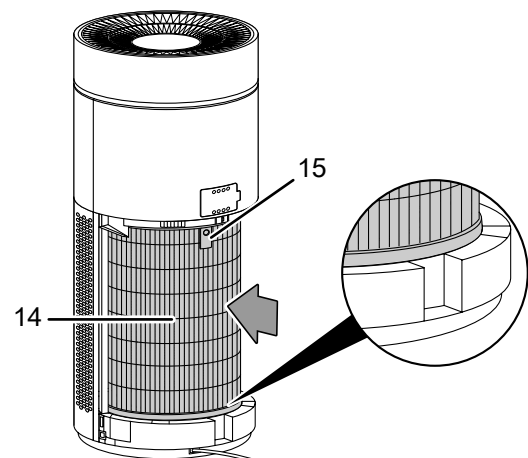

6. Put the device cover back on the device. To do so, insert the lower hooks of the device cover into the corresponding notches of the device and then push the top of the cover onto the device. Make sure that the cover is fitted correctly.

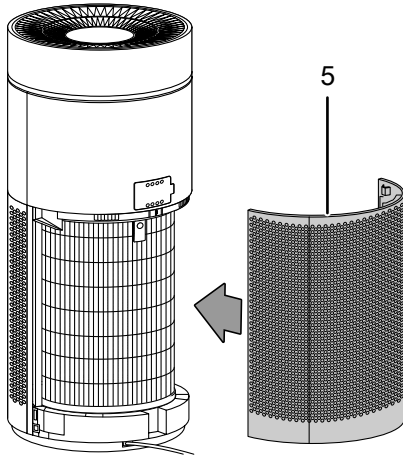

### Activities required after maintenance

If you want to continue using the device:

- Reconnect the device to the mains.

If you do not intend to use the device for a considerable time:

- Store the device according to the Transport and storage chapter.

7. Press the *fan speed* button (11) for two seconds to reset the *filter change* LED.
  - ⇒ The *filter change* LED goes out and the device enters standby mode.

### Cleaning the air quality sensor

The air quality sensor (4) has to be cleaned once it is soiled or if the *air quality* LED (8) is illuminated in red for a longer period of time (please also refer to the Chapter Operation and the Chapter Errors and faults).

1. Clean the sensor cover using a soft, lint-free cloth.
2. Open the sensor cover by unfolding the cover.
3. Carefully clean the sensor lens (16) with a cotton bud slightly moistened with water. Do not use too much water as this could damage the sensor.

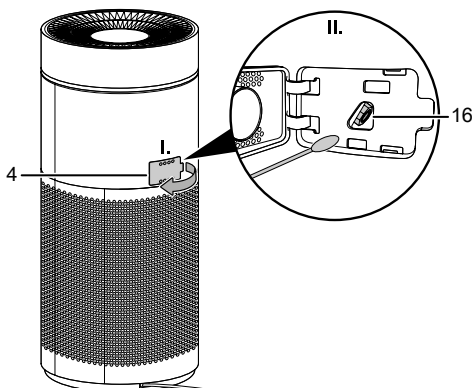

4. Carefully dry the lens with a dry cotton bud.
5. Then close the sensor cover again.

## Technical annex

### Technical data

Parameter	Value
Model	AirgoClean® 170 + AirgoClean® 171 E
Air flow rate with HEPA carbon filter	
Fan stage 1	119 m <sup>3</sup> /h
Fan stage 2	168 m <sup>3</sup> /h
Fan stage 3	263 m <sup>3</sup> /h
Fan stage 4	303 m <sup>3</sup> /h
Fan stage 5	350 m <sup>3</sup> /h
Ambient temperature	5 °C to 40 °C
Operating range	30 % to 90 % RH
Mains connection	220–240 V ~ 50/60 Hz
Power consumption	33 W
Nominal current	0.14 A
Dimensions (length x width x height)	292 x 292 x 663 mm
Minimum distance to walls and other objects	
A: top	30 cm
B: rear	30 cm
C: side	30 cm
D: front	30 cm
Weight	6.5 kg

### Disposal

Always dispose of packing materials in an environmentally friendly manner and in accordance with the applicable local disposal regulations.



The icon with the crossed-out waste bin on waste electrical or electronic equipment is taken from Directive 2012/19/EU. It states that this device must not be disposed of with the household waste at the end of its life. You will find collection points for free return of waste electrical and electronic equipment in your vicinity. The addresses can be obtained from your municipality or local administration. You can also find out about other return options that apply for many EU countries on the website <https://hub.trotec.com/?id=45090>. Otherwise, please contact an official recycling centre for electronic and electrical equipment authorised for your country.

The separate collection of waste electrical and electronic equipment aims to enable the re-use, recycling and other forms of recovery of waste equipment as well as to prevent negative effects for the environment and human health caused by the disposal of hazardous substances potentially contained in the equipment.

#### Only for United Kingdom

According to Waste Electrical and Electronic Equipment Regulations 2013 (SI 2013/3113) (as amended) devices that are no longer usable must be collected separately and disposed of in an environmentally friendly manner.

Trotec GmbH

Grebener Str. 7  
D-52525 Heinsberg

☎ +49 2452 962-400

☎ +49 2452 962-200

✉ [info@trotec.com](mailto:info@trotec.com)

[www.trotec.com](http://www.trotec.com)