

PAC 2100 X / PAC 2600 X

EN

INSTRUCTIONS
LOCAL AIR CONDITIONER



 **TROTEC**

Table of contents

Information on the use of these instructions 2

Safety 2

Information about the device..... 6

Transport and storage..... 7

Assembly and start-up 7

Operation 11

Errors and faults..... 16

Maintenance 18

Technical annex..... 22

Disposal 28

You can download the current version of these instructions via the following link:

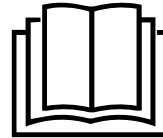

PAC 2100 X



<https://hub.trotec.com/?id=43227>

PAC 2600 X



<https://hub.trotec.com/?id=43228>

Information on the use of these instructions

Symbols

- Danger**
This signal word indicates a hazard with a high risk level which, if not avoided, will result in serious injury or death.
- Danger**
This symbol indicates dangers to the life and health of persons due to extremely flammable gas.
- Warning**
This signal word indicates a hazard with an average risk level which, if not avoided, can result in serious injury or death.
- Warning of electrical voltage**
This symbol indicates dangers to the life and health of persons due to electrical voltage.
- Notice**
This signal word indicates important information (e.g. material damage), but does not indicate hazards.
- Info**
Information marked with this symbol helps you to carry out your tasks quickly and safely.
- Follow the manual**
Information marked with this symbol indicates that the instructions must be observed.

Safety

Read this manual carefully before starting or using the device. Always store the manual in the immediate vicinity of the device or its site of use.

- Warning**
Read all safety warnings and all instructions. Failure to follow the warnings and instructions may result in electric shock, fire and/or serious injury. **Save all warnings and instructions for future reference.**
This appliance can be used by children aged from 8 years and above and persons with reduced physical, sensory or mental capabilities or lack of experience and knowledge if they have been given supervision or instruction concerning use of the appliance in a safe way and understand the hazards involved. Children shall not play with the appliance. Cleaning and user maintenance shall not be done by children without supervision.
- Do not use the device in potentially explosive rooms or areas and do not install it there.
- Do not use the device in an aggressive atmosphere.
- Place the device in an upright and stable position on a horizontal and stable surface.
- Let the device dry out after a wet clean. Do not operate it when wet.
- Do not use the device with wet or damp hands.
- Do not expose the device to directly squirting water.

- Never insert any objects or limbs into the device.
- Do not cover the device during operation.
- Do not sit on the device.
- This appliance is not a toy. Keep away from children and animals.
- Check accessories and connection parts for possible damage prior to every use of the device. Do not use any defective devices or device parts.
- Ensure that all electric cables outside of the device are protected from damage (e.g. caused by animals). Never use the device if electric cables or the power connection are damaged!
- The mains connection must correspond to the specifications in the Technical annex.
- Insert the mains plug into a properly fused mains socket.
- Observe the technical data when selecting extensions to the power cable. Completely unroll the extension cable. Avoid electrical overload.
- Before carrying out maintenance, care or repair work on the device, remove the mains plug from the mains socket. Hold onto the mains plug while doing so.
- Switch the device off and disconnect the power cable from the mains socket when the device is not in use.
- Do not under any circumstances use the device if you detect damages on the mains plug or power cable. If the supply cord is damaged, it must be replaced by a special cord or assembly available from the manufacturer or its service agent.
Defective power cables pose a serious health risk!
- When positioning the device, observe the minimum distances from walls and other objects as well as the storage and operating conditions specified in the Technical annex.
- Make sure that the air inlet and outlet are not obstructed.
- Do not remove any safety signs, stickers or labels from the device. Keep all safety signs, stickers and labels in legible condition.
- Make sure that the suction side is kept free of dirt and loose objects.
- Only transport the device in an upright position with an emptied condensation tray or drain hose.
- Discharge the collected condensate before transport and storage. Do not drink it. Health hazard!
- Use batteries of type AAA.
- Do not insert rechargeable batteries into the remote control.
- Never charge batteries that cannot be recharged.
- Different types of batteries and new and used batteries must not be used together.
- Insert the batteries into the battery compartment according to the correct polarity.
- Remove discharged batteries. Batteries contain materials hazardous to the environment. Dispose of the batteries according to the national regulations.
- Remove the batteries from the remote control if you will not be using the device for a longer period of time.
- Never short-circuit the terminals of batteries!
- Do not swallow batteries! If a battery is swallowed, it can cause severe internal burns within 2 hours! These burns can lead to death!
- If you think batteries might have been swallowed or otherwise entered the body, seek medical attention immediately!
- Keep new and used batteries and an open battery compartment away from children.
- If the battery compartment does not close securely, stop using the product via the remote control.
- Only position the device in rooms where potentially leaking refrigerant cannot accumulate. Unventilated rooms in which the device is installed, operated or stored must be built in a way to ensure that potentially leaking refrigerant cannot accumulate. This serves to avoid fire or explosion hazards resulting from an ignition of the refrigerant by an electric furnace, cooking stove or another ignition source.
- Only install the device in compliance with the national installation regulations.
- Only install, operate and store the device PAC 2100 X in a room measuring more than 7 m².
- Only install, operate and store the device PAC 2600 X in a room measuring more than 9 m².
- Store the device in a way that no mechanical damage can occur.
- The entire refrigerant circuit is a maintenance-free, hermetically sealed system and may only be maintained or repaired by specialist companies for cooling and air-conditioning or by the manufacturer.

Safety instructions for servicing the refrigerant circuit:

- Every person working with or at the refrigerant circuit must be able to provide a certificate of qualification issued by a body accredited by the industry, demonstrating their competence in the safe use of refrigerants based on a procedure well-known in the industry.
- Service work may only be carried out in accordance with the manufacturer's specifications. If maintenance and repair work require the support of additional persons, the person trained in handling flammable refrigerants shall continuously supervise the work carried out.
- Do not store the device together with ignition sources in rooms without ventilation.

Warning

- Do not use any means other than those recommended by the manufacturer for accelerating the defrosting process or cleaning the device.
- Do not drill into or burn.
- Please note that the refrigerant is odourless.
- Observe the national regulations for gas installations.
- Observe the maximum refrigerant capacity in the technical data.
- R290 is a refrigerant that complies with European environmental regulations. No part of the cooling circuit may be perforated.

Intended use

Only use the device for cooling, ventilating and dehumidifying indoor air whilst adhering to the technical data.

Any use other than the intended use is regarded as misuse.

Reasonably foreseeable misuse

- Do not place the device on wet or flooded ground.
- Do not place any objects, e.g. clothing, on the device.
- Do not use outdoors.
- Never immerse the device in water.
- Do not make any unauthorised modifications, alterations or structural changes to the device.
- Do not use the device in the immediate vicinity of swimming pools, bathtubs and showers.

Personnel qualification

People who use this device must:

- have basic knowledge of how to safely handle electrical equipment.
- have read and understood the instructions, especially the Safety chapter.

Maintenance tasks which require the housing to be opened must only be carried out by specialist companies for cooling and air-conditioning or by the manufacturer.

Safety signs and labels on the device

Notice

Do not remove any safety signs, stickers or labels from the device. Keep all safety signs, stickers and labels in legible condition.

The following safety signs and labels are attached to the device:

PAC 2100 X

WARNING • WARNUNG • ATTENTION

DE Das Gerät muss in einem Raum mit einer Grundfläche größer als 7 m² aufgestellt, betrieben und gelagert werden.
 EN Appliance shall be installed, operated and stored in a room with floor area larger than 7 m².
 FR L'appareil doit être installé, utilisé et entreposé dans une pièce avec une surface supérieure à 7 m².



PAC 2600 X

WARNING • WARNUNG • ATTENTION

DE Das Gerät muss in einem Raum mit einer Grundfläche größer als 9 m² aufgestellt, betrieben und gelagert werden.
 EN Appliance shall be installed, operated and stored in a room with floor area larger than 9 m².
 FR L'appareil doit être installé, utilisé et entreposé dans une pièce avec une surface supérieure à 9 m².



Follow the manual

This symbol indicates that the instructions must be observed.



Follow the repair manual

Disposal, maintenance and repair work of the refrigerant circuit may only be carried out in accordance with the manufacturer's specifications and by persons having a certificate of qualification. A corresponding repair manual is available from the manufacturer upon request.

!!! ACHTUNG !!!

1. Vor Inbetriebnahme MIND. 12 STUNDEN aufrecht und still stehen lassen! Das schützt den Kompressor, verlängert die Lebensdauer erheblich und verhindert so einen Verlust der Kühlleistung.
2. Das Klimagerät muss immer BESONDERS VORSICHTIG auf den Boden gestellt werden! Ansonsten können Mikrorisse in der Bodenplatte und der Kondensatwanne entstehen, was dazu führt, dass Kondenswasser auf den Boden tropft.

Für Schäden, die durch unsachgemäßen Gebrauch entstehen, übernehmen wir KEINE GEWÄHRLEISTUNG!

!!! WARNING !!!

1. Before operation, stand upright and rest for MIN 12 HOURS! This protects the compressor, greatly extending its life and preventing loss of cooling performance.
2. The air conditioner must always be placed on the floor with CAUTION! Otherwise, microcracks may form in the bottom plate and the condensate pan, causing condensation to drip onto the floor.

For damages caused by improper use, WARRANTY WILL BE NULL AND VOID!

!!! ATTENTION !!!

1. Avant la mise en service, laissez immobile en position verticale PENDANT AU MOINS 12 HEURES ! Cela protège le compresseur, prolonge sensiblement la durée de vie et évite ainsi une diminution des performances de refroidissement.
2. Le climatiseur doit toujours être posé sur le sol AVEC LES PLUS GRANDES PRÉCAUTIONS ! Sinon, des micro-fissures risquent de se former dans le socle ou le bac de récupération de l'eau de condensation, ce qui entraînerait que cette dernière coule sur le sol.

Toute utilisation incorrecte ou non conforme entraîne L'EXTINCTION DE LA GARANTIE !

Residual risks



Danger

Natural refrigerant propane (R290)!

H220 – Extremely flammable gas.

H280 – Contains gas under pressure; may explode if heated.

P210 – Keep away from heat, sparks, open flames and other ignition sources. No smoking.

P377 – Leaking gas fire: Do not extinguish, unless leak can be stopped safely.

P410+P403 – Protect from sunlight. Store in a well-ventilated place.



Warning of electrical voltage

Risk of electric shock!

Risk of an electric shock if the device comes into contact with water!

Do not use this device in the immediate vicinity of bathtubs, showers or swimming pools!



Warning of electrical voltage

Work on the electrical components must only be carried out by an authorised specialist company!



Warning of electrical voltage

Before any work on the device, remove the mains plug from the mains socket!

Do not touch the mains plug with wet or damp hands. Hold onto the mains plug while pulling the power cable out of the mains socket.



Warning of electrical voltage

Risk of electric shock!

The device is not protected against water.

There is a risk of electric shock!

Never use the device in areas where dripping, spraying or running water can enter the device! Never immerse the device in water!

Notice

Do not operate the device without an inserted air filter! Without the air filter, the inside of the device will be heavily contaminated. This could reduce the performance and result in damage to the device.

Behaviour in the event of an emergency

1. Switch the device off.
2. Disconnect the device from the mains by removing the mains plug from the socket. When doing so, be sure to hold the plug, not the cable.
3. Do not reconnect a defective device to the mains.

Information about the device

Device description

The device serves the purpose of cooling the room air. It further filters and dehumidifies the air thus creating an agreeable room climate.

The unit cools the room air by withdrawing warmth.

The absorbed warmth is emitted to the outside via the exhaust air hose; cooled air is fed to the installation site by means of a fan.

Accumulating condensate drips from the evaporator onto the hot condenser, there it evaporates and then is transported to the outside via the exhaust air hose.

In *ventilation* mode the device provides the opportunity of air circulation without cooling effect.

In *dehumidification* mode moisture is withdrawn from the air.

The device operates fully automatically and features a variety of further options. The device can, for instance, be switched on or off automatically with time delay via the timer function.

Operation of the device is possible either via the control panel at the device or via the supplied infrared remote control.

The device was designed for universal and flexible application.

Due to its compact dimensions it can be easily transported and used in all interior spaces.

The device is not protected against water (IPX0).

Device depiction

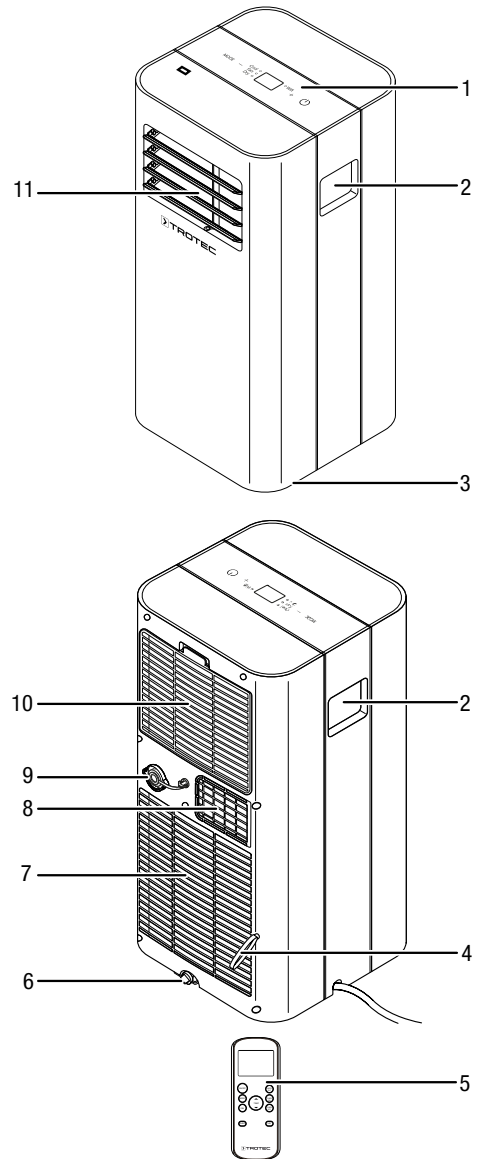

No.	Designation
1	Control panel
2	Handle
3	Wheels
4	Power cable holder
5	Remote control
6	Condensate outlet with rubber stopper
7	Air inlet
8	Exhaust air hose connection
9	Hose connector with sealing cap and rubber stopper
10	Air inlet with air filter
11	Air outlet with ventilation flaps

Transport and storage

Notice

If you store or transport the device improperly, the device may be damaged.

Note the information regarding transport and storage of the device.

Transport

Please note that additional transport regulations might apply to devices containing flammable refrigerants. The equipment's arrangement and the maximum number of components to be transported together can be gathered from the applicable transport regulations.

To make the device easier to transport, it is fitted with wheels.

Before transporting the device, observe the following:

- Switch the device off.
- Disconnect the device from the mains by removing the mains plug from the socket. When doing so, be sure to hold the plug, not the cable.
- Drain the remaining condensate from the device.
- Do not use the power cable to drag the device.
- Only wheel the device on firm and level surfaces.

After transporting the device, proceed as follows:

- Set up the device in an upright position after transport.
- Leave the device to rest for at least 12 hours, so the refrigerant can accumulate within the compressor. Wait 12 hours before switching the device back on! Acting contrary might lead to compressor damage and a malfunctioning device.

Storage

Before storing the device, observe the following:

- Drain the remaining condensate from the device.
- Disconnect the device from the mains by removing the mains plug from the socket. When doing so, be sure to hold the plug, not the cable.

When the device is not being used, observe the following storage conditions:

- Only store the device PAC 2100 X in a room measuring more than 7 m².
- Only store the device PAC 2600 X in a room measuring more than 9 m².

Warning

- Store the appliance in a room without continuously operating open flames (for example an operating gas appliance) or other potential ignition sources (for example an operating electric heater, hot surfaces);
- Store the device in a dry location and protected from frost and heat.

- Store the device in an upright position where it is protected from dust and direct sunlight.
- If required, use a cover to protect the device from invasive dust.
- Place no further devices or objects on top of the device to prevent it from being damaged.
- Remove the batteries from the remote control.

Assembly and start-up

Scope of delivery

- 1 x Device
- 1 x Exhaust air hose
- 1 x Hose adapter
- 1 x Adapter for wall mounting
- 1 x Condensation drain hose, length: 0.6 m, diameter: 14.8 mm
- 1 x Transition from exhaust air hose to wall adapter
- 4 x Screw
- 4 x Wall plug
- 1 x Remote control (without batteries)
- 1 x Manual

Unpacking the device



Warning

There is a danger of suffocation for children due to packaging material! Keep packaging films and parts away from children. There is a risk of death due to suffocation.

1. Open the cardboard box and take the device out.
2. Completely remove the packaging.
3. Fully unwind the power cable. Make sure that the power cable is not damaged and that you do not damage it during unwinding.

Start-up

When positioning the device, observe the minimum distance from walls or other objects as described in the Technical data chapter.

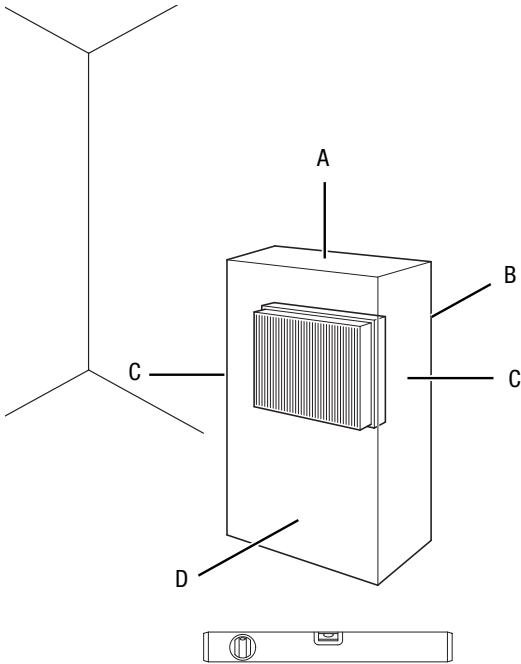

- Before restarting the device, check the condition of the power cable. If there are doubts as to the sound condition, contact the customer service.
- Only position the device in rooms where potentially leaking refrigerant cannot accumulate.
- Place the device in an upright and stable position on a horizontal and stable surface.
- Do not create tripping hazards when laying the power cable or other electric cables, especially when positioning the device in the middle of the room. Use cable bridges.
- Make sure that extension cables are completely unrolled.
- Keep air inlets and outlets as well as the exhaust air hose connection free.
- Make sure that no curtains or other objects interfere with the air flow.

Inserting batteries into the remote control

Notice

Do not use rechargeable batteries!

Please proceed as follows to insert or exchange the batteries:

1. Press the upper part on the back of the remote control and pull the battery cover off the remote control.
2. Insert two AAA batteries into the battery compartment adhering to the correct polarity.
3. Slide the battery cover back onto the remote control.

Inserting the air filter

Notice

Do not operate the device without an inserted air filter! Without the air filter, the inside of the device will be heavily contaminated. This could reduce the performance and result in damage to the device.

- Make sure that the air filter is installed before switching the device on.

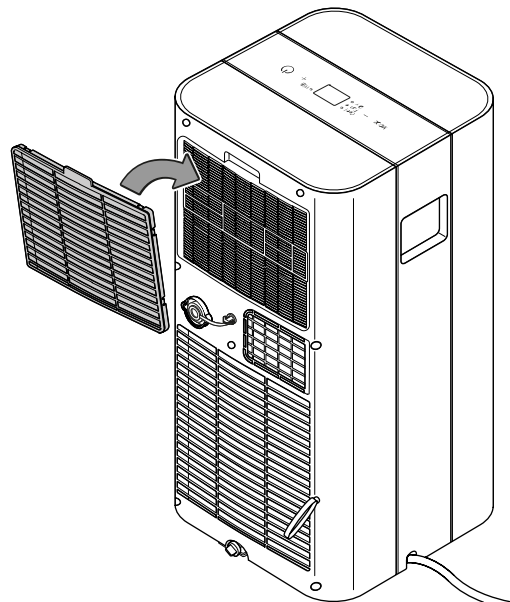

Connecting the exhaust air hose

1. Connect the hose adapter to the other end of the exhaust air hose.

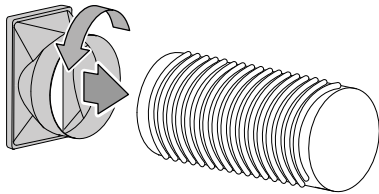

2. Shove the hose adapter with exhaust air hose sideways into the air conditioner's exhaust air hose connection.

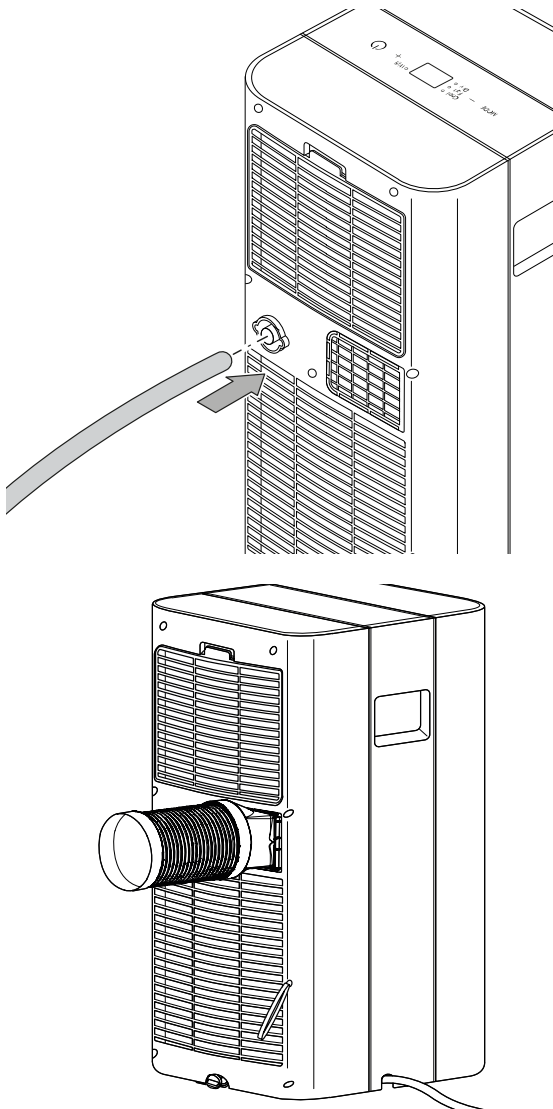

Discharging exhaust air

- The exhaust air coming from the device contains waste heat from the room to be cooled. For this reason it is recommended to discharge the exhaust air to the outside.
- The end of the exhaust air hose can be fed through the open window. If required, secure the open window with the corresponding means, so that the end of the exhaust air hose cannot shift.
- The end of the exhaust air hose can also be hooked into a tilted window. For this purpose, we recommend using a window seal (optional).
- Install the exhaust air hose inclined with the air direction.
- The connected hose must not contain any source of ignition.

Example with exhaust air hose:

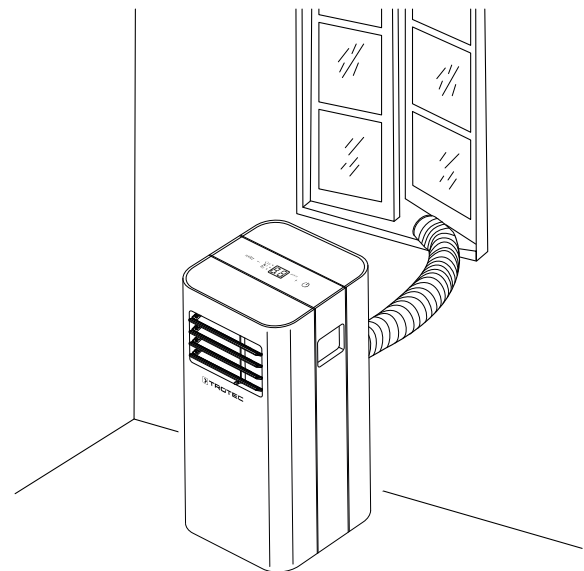

For installing the exhaust air hose please observe the following:

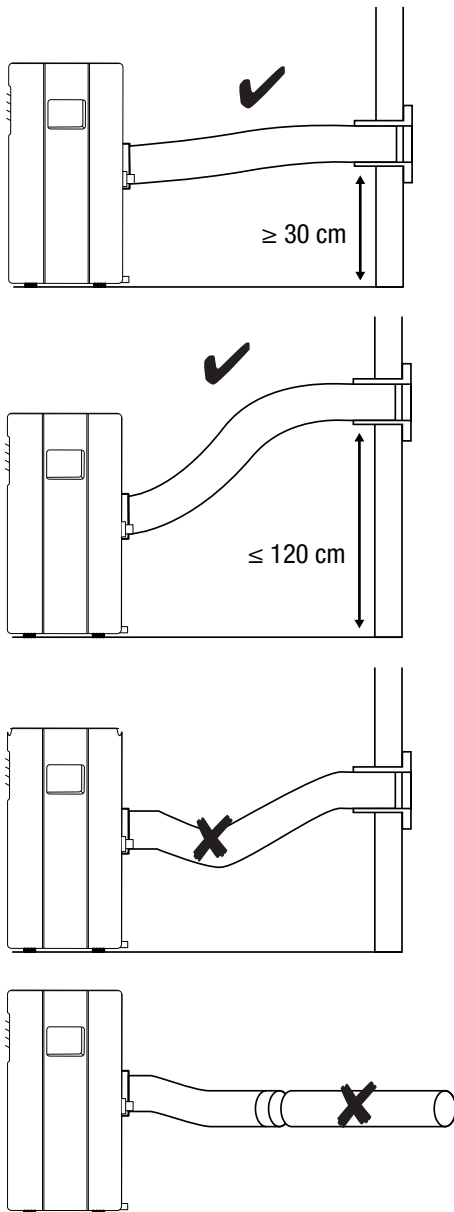

Opening the ventilation flaps

1. Prior to switching the device on, open the ventilation flaps at the air outlet.

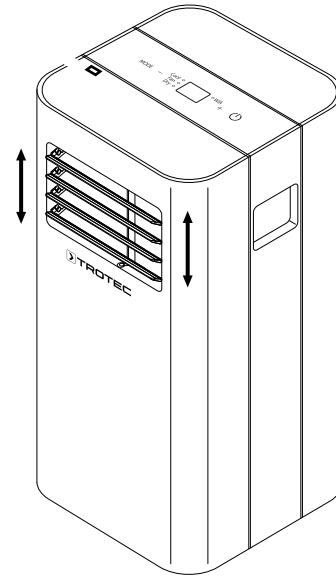

Connecting the power cable

- Connect the mains plug to a properly secured socket.

- Avoid kinks in the exhaust air hose. Kinks and bends would lead to an accumulation of emitted humid air causing the device to overheat and shut down.
- The dimensions of the exhaust air hose were especially made to fit the device. Do not replace or extend the hose. This could cause a malfunction of the device.

Operation

- Avoid open doors and windows.

Operating elements

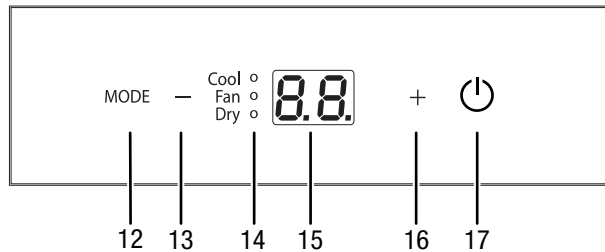

No.	Designation	Meaning
12	MODE button	Selecting the operating mode: <i>Cooling</i> <i>Ventilation</i> <i>Dehumidification</i>
13	Minus button	For reducing the target temperature (17 °C to 30 °C) for cooling
14	Operating mode LED	Indicates the selected operating mode: <i>Cool</i> = cooling <i>Fan</i> = ventilation <i>Dry</i> = dehumidification
15	Segment display	Indication of the target temperature in <i>Cooling mode</i> Indication of the error code, see chapter Errors and faults
16	Plus button	For increasing the target temperature (17 °C to 30 °C) for cooling
17	On/off button	For switching the device on or off



Warning of electrical voltage

Risk of electric shock!

The device is not protected against water.

There is a risk of electric shock!

Never use the device in areas where dripping, spraying or running water can enter the device! Never immerse the device in water!



Info

An acoustic signal is emitted each time a setting is activated.

Switching the device on

1. Allow the device to stand for 12 hours if it has been moved.
2. Once you have completely installed the device as described in the Start-up chapter, you can switch it on.
3. Press the Power button (17).
⇒ The device switches on.
4. Select the desired operating mode.

The device switches off automatically when the condensation tank is full. *P1* is displayed in the segment display (15).

Setting the operating mode

Cooling

In *Cooling* mode the room will be cooled down to the desired target temperature.

1. Press the *MODE* button (12) until the *Cool* LED (14) is illuminated.
⇒ *Cooling* mode is selected.
2. Select the desired target temperature by use of the Plus (16) or Minus (13) buttons. Temperatures between 17 °C and 30 °C can be selected.
⇒ The currently selected target temperature is shown on the segment display (15).
3. The fan stage can be adjusted via the remote control: Press the *FAN* button (26) to set the desired fan stage.
⇒ The fan stage is shown in the *FAN* indication (34).

Dehumidification

In *Dehumidification* mode the humidity level in the room is reduced.

The temperature cannot be adjusted and the fan runs at the lowest speed level.



Info

Remove the exhaust air hose during *Dehumidification*, otherwise the performance will be insufficient.

1. Press the *MODE* button (12) until the *Dry* LED (14) is illuminated.
⇒ *Dehumidification* mode is selected.



Info

If the device is operated in a very humid environment, the accumulating condensate must be discharged at regular intervals (see Condensate discharge).

Connecting the condensation drain hose

If you use the device for an extended period of time or you don't want to empty the tank all the time, you can connect a condensation drain hose to the hose connection.

- ✓ The device is switched off.
- ✓ The device is disconnected from the mains.
- 1. Check whether there is a drain at the installation site or provide a suitable collection container under the condensate outlet.
- 2. Unscrew the sealing cap counter-clockwise from the hose connection (9).
- 3. Remove the rubber stopper from the hose connection.

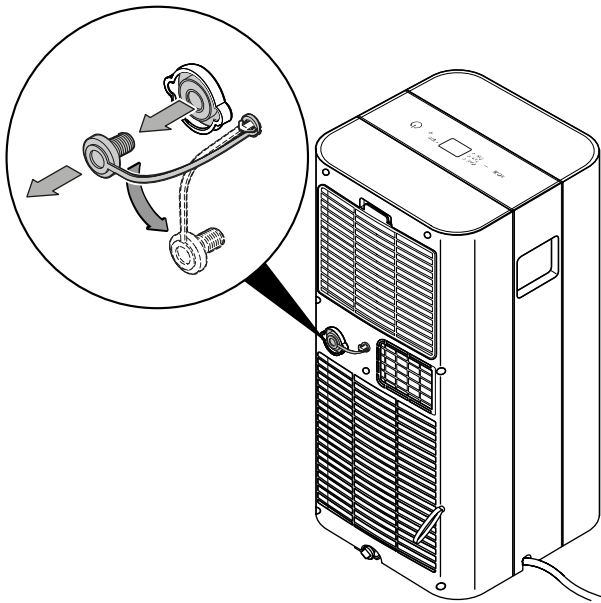

- 4. Keep sealing cap and rubber stopper for later use.
- 5. Connect the condensation drain hose to the hose connection (9).

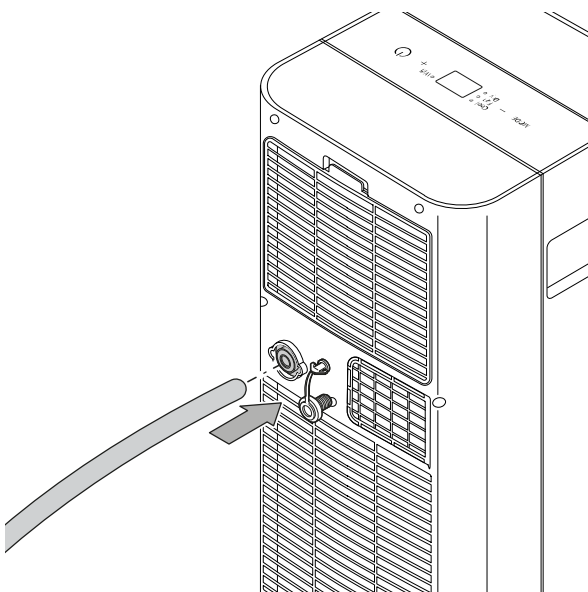

- 6. Guide the other hose end to a suitable drain or sufficiently dimensioned collection container. To ensure that the condensate can run off, the condensation drain hose must not be kinked, nor should it have to overcome an uphill incline towards the drain.

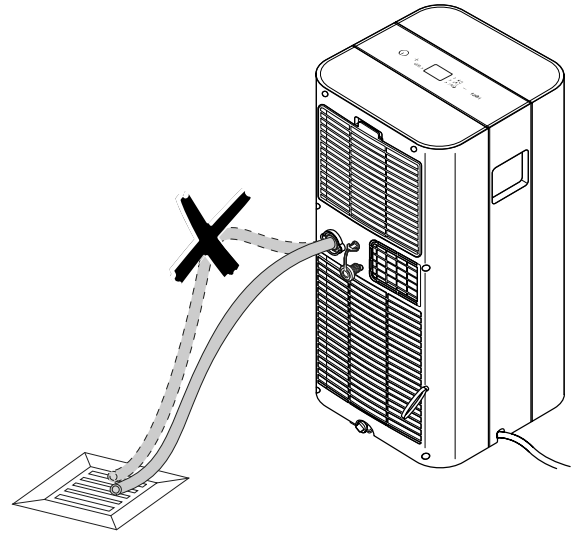

Ventilation

In *Ventilation* mode the room air is circulated, it will neither be cooled nor dehumidified.

The automatic stage depends on the current room temperature and the set target temperature. The fan speed increases with a high room temperature. The fan speed decreases in case of a low room temperature.



Info

Remove the exhaust air hose during *Ventilation*.

- 1. Press the *MODE* button (12) until the *Fan* LED (14) is illuminated.
 - ⇒ *Ventilation* mode is selected.
- 2. The fan stage can be adjusted via the remote control: Press the *FAN* button (26) to set the desired fan stage.
 - ⇒ The selected operating mode and fan stage are indicated on the display (19).

Changing the unit °C / °F

The temperature can be indicated in either °C or °F on the remote control's display (19) and on the segment display (15) of the device.

- 1. Simultaneously press and hold the Plus (16) and Minus (13) buttons for 3 seconds.
 - ⇒ The displayed temperature is converted to the other unit.

Alternatively, this adjustment can be made via the remote control.

- 1. Press the arrow button (27) for 3 seconds.
 - ⇒ The displayed temperature is converted to the other unit.

Remote control

All settings of the device can also be made using the remote control included in the scope of delivery.

Insert suitable batteries in the remote control (see chapter Technical annex).



Info

After a longer period of non-use, the remote control will switch to standby mode. Standby mode can be terminated by pressing the *ON/OFF* button (29) on the remote control. The device automatically uses the current settings entered via the remote control.

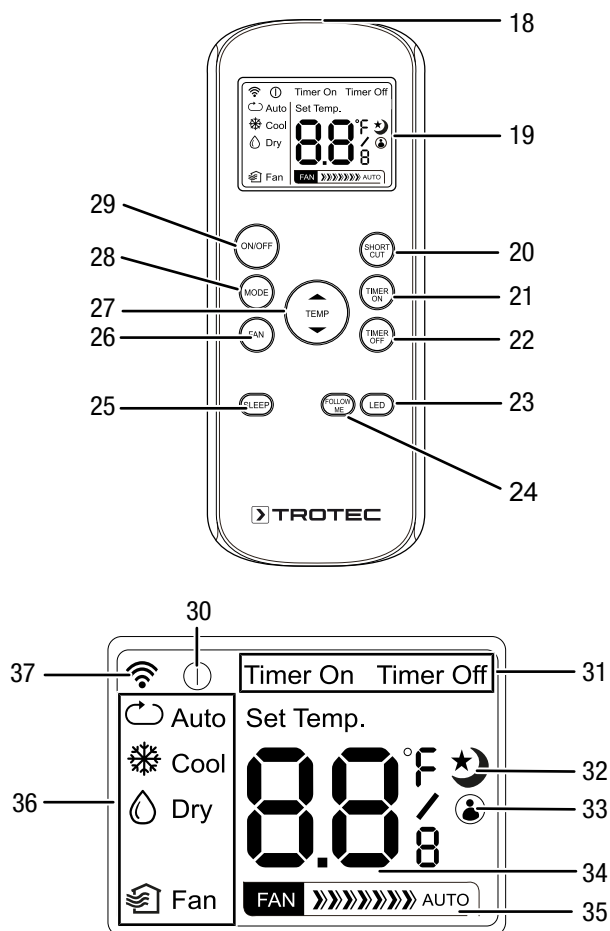

No.	Designation	Meaning
23	<i>LED</i> button	For switching the LEDs on the control panel on or off
24	<i>FOLLOW ME</i> button	For switching the Follow Me function on or off
25	<i>SLEEP</i> button	For switching night mode on or off
26	<i>FAN</i> button	Setting the fan stage: stage 1 = low fan speed stage 2 = high fan speed The automatic stage can be selected also.
27	Arrow button	Setting the target temperature for cooling Setting the number of hours for the timer (0.5 to 24 h) Changing the unit °C / °F
28	<i>MODE</i> button	Selecting the operating mode: <i>Auto</i> = automatic operation <i>Cool</i> = cooling <i>Dry</i> = dehumidification <i>Fan</i> = ventilation
29	<i>ON/OFF</i> button	Power button: For switching the device on or off
30	Standby indication	Displayed when the remote control is in standby mode
31	<i>Timer On/Off</i> indication	Displayed for automatic switch-on/-off with programmed timer
32	Night mode indication	Displayed when night mode is activated
33	<i>FOLLOW ME</i> indication	Displayed when the Follow Me function is activated
34	Segment display	Indication of the target temperature Indication of preferred settings °C / °F indication Indication of the set number of hours during timer programming
35	<i>FAN</i> indication	Indicates the fan stage
36	Operating mode indication	Indicates the selected operating mode
37	Transmitter indication	Displayed during communication between device and remote control

No.	Designation	Meaning
18	Signal receiver	Communication between device and remote control using infrared
19	Display	Indication of different device functions
20	<i>SHORT CUT</i> button	Saving preferred settings Returning to the previous setting
21	<i>TIMER ON</i> button	<i>Automatic switch-on</i> timer function in increments of 0.5 hours (0 to 10 h) or in increments of 1 hour (10 to 24 h)
22	<i>TIMER OFF</i> button	<i>Automatic switch-off</i> timer function in increments of 0.5 hours (0 to 10 h) or in increments of 1 hour (10 to 24 h)

Setting the timer

The timer has two modes of operation:

- automatic switch-on upon expiry of a preset number of hours
- automatic switch-off upon expiry of a preset number of hours

The timer can be programmed in increments of 0.5 hours (0 to 10 h) or in increments of 1 hour (10 to 24 h).

This setting can only be made using the remote control.

The function can be set in all operating modes. It can be activated both during operation and in standby mode.

Automatic switch-on and *Automatic switch-off* may be enabled at the same time. If so, *Timer On* and *Timer Off* will both be displayed (19) simultaneously.



Info

The set number of hours is only indicated on the remote control's display (19).

Notice

The device must not be left unattended in a freely accessible room with an activated timer.

Automatic switch-on

- ✓ The device is switched off.
- 1. Press the *TIMER ON* button (21) to activate the timer.
- 2. Hold or repeatedly press the *TIMER ON* button (21) to select the desired number of hours until automatic switch-on.
- 3. Wait for 3 seconds to confirm the setting.
 - ⇒ The number of hours until automatic switch-on is indicated on the display (19) for approximately 3 seconds.
 - ⇒ The *Timer On* setting will also be indicated on the display (19).
 - ⇒ A dot will be indicated in the bottom right corner of the segment display (15).
 - ⇒ After the predefined time, the device switches itself on.

Notes regarding automatic switch-on:

- If the device is disconnected from the power supply, all settings for automatic switch-on are deleted.
- Manually switching the device on disables the automatic switch-on function.
- If you select **0** hours, the timer will be off.

Automatic switch-off

- ✓ The device is switched on.
- 1. Press the *TIMER OFF* button (22) to activate the timer.
- 2. Hold or repeatedly press the *TIMER OFF* button (22) to select the desired number of hours until automatic switch-off.
- 3. Wait for 3 seconds to confirm the setting.
 - ⇒ The number of hours until automatic switch-off is indicated on the display (19) for approximately 3 seconds.
 - ⇒ The *Timer Off* setting will also be indicated on the display (19).
 - ⇒ A dot will be indicated in the bottom right corner of the segment display (15).
 - ⇒ After the predefined time, the device switches itself off.

Automatic operation

During automatic operation cooling and ventilation are regulated depending on the ambient and target temperature.

This setting can only be made using the remote control.

1. Use the *MODE* button (28) to select *Auto* mode.
 - ⇒ *Auto* mode is displayed in the operating mode indication (36).

Night mode

Night mode can be activated in *Cooling* mode and during *Automatic operation*.

This setting can only be made using the remote control.

Night mode comes with the following settings:

- After 30 minutes the preset temperature is increased by 1 °C. After 1 hour the preset temperature will again be increased by 1 °C. Then the temperature is kept constant for 7 hours.
Subsequently, the device switches back to the preset temperature from before night mode.
- Ventilation is preset to the automatic stage and cannot be adjusted.

To activate night mode, please proceed as follows:

1. Select *Cooling* mode or *Automatic operation*.
2. Press the *SLEEP* button (25).
 - ⇒ Both the night mode and the automatic stage will be indicated on the display (19).
3. In order to switch the night mode off, press the *SLEEP* button (25) once again.
 - ⇒ The night mode indication (32) disappears.
 - ⇒ The automatic stage remains unaffected.

Switching the LEDs on the control panel on or off

The control panel illumination at the devices can be switched on and off.

This setting can only be made using the remote control.

1. Press the *LED* button (23).
 - ⇒ The LEDs on the control panel will be switched off.
 - ⇒ The device continues to run with the selected settings.
2. Press the *LED* button (23) again.
 - ⇒ The LEDs on the control panel will be switched back on.

Saving preferred settings

You can save your preferred settings and return to the previous setting.

This setting can only be made using the remote control.

1. Press and hold the *SHORT CUT* button (20) for 3 seconds.
 - ⇒ The display (19) goes blank for 1 seconds.
 - ⇒ The current settings including operating mode, target temperature, fan stage and night mode (if activated) will be saved.
2. Press and hold the *SHORT CUT* button (20) for 1 seconds.
 - ⇒ The display (19) goes blank for 1 seconds.
 - ⇒ The device returns to the previous setting including operating mode, target temperature, fan stage and night mode (if activated).
3. In order to delete the settings, press the *SHORT CUT* button (20) again for 3 seconds.
 - ⇒ The display (19) goes blank for 1 seconds.
 - ⇒ The settings are now deleted.

Follow Me function

Using the Follow Me function, the remote control measures the temperature at your current location. The degree of cooling is controlled by the air conditioner based on the measured temperature.

The Follow Me function can be activated in *cooling* mode and during *automatic operation*.

1. Press the *FOLLOW ME* button (24).
 - ⇒ The *FOLLOW ME* indication (38) appears on the display (19).
 - ⇒ The remote control sends a temperature signal to the air conditioner every 3 minutes.
2. Press the *FOLLOW ME* button (24) again to disable the Follow Me function.

Memory function

After a power failure during operation the device will automatically be switched back on. The chosen operating mode settings will be saved, a possibly programmed timer will not.

All the chosen settings (incl. timer) remain saved on the remote control. As soon as the device receives an input from the remote control, the settings will be transmitted from the remote control to the device.

The compressor may start up with a delay of 3 minutes, as it is provided with an internal protection against direct restart.

Energy saving

Upon reaching the preselected target temperature the compressor will be switched off automatically in order to reduce the power consumption.

Once the preselected target temperature is exceeded, the compressor switches back on.

Automatic defrosting

At low ambient temperatures, ice may form at the evaporator. The device will then perform automatic defrosting.

The compressor switches off and the fan keeps running until defrosting is completed. The duration of defrosting can vary.

Do not switch off the device during automatic defrosting. Do not remove the mains plug from the mains socket.

Notice

The device must not be left unattended in a freely accessible room with an activated timer.

Shutdown



Warning of electrical voltage

Do not touch the mains plug with wet or damp hands.

- Switch off the device.
- Disconnect the device from the mains by removing the mains plug from the socket. When doing so, be sure to hold the plug, not the cable.
- Empty the condensation tray if necessary.
- If necessary, remove the condensation drain hose and any residual fluid from it.
- If required, clean the device according to the "Maintenance" chapter.
- Store the device according to the Transport and storage chapter.

Errors and faults

The device has been checked for proper functioning several times during production. If malfunctions occur nonetheless, check the device according to the following list.

Notice

Wait for at least 3 minutes after maintenance and repair work. Only then switch the device back on.

The device does not start:

- Check the power connection.
- Check the power cable and mains plug for damage. If you notice damages, do not try to take the device back into operation.
If the supply cord is damaged, it must be replaced by the manufacturer, its service agent or similarly qualified persons in order to avoid a hazard.
- Check the on-site fusing.
- Observe the operating temperature according to the chapter Technical annex.
- The condensation tank may be full. Empty the condensation tank, if need be. The error code *P1* must not be indicated on the segment display.
- If the device is not starting, have the electricians checked by a specialist company or by the manufacturer.

The device works with reduced or no cooling capacity:

- Check whether *cooling* mode is selected.
- Check the proper fit of the exhaust air hose. In case of kinks, bends or blockage in the hose, exhaust air cannot be discharged. Clear the way for the exhaust air.
- Check the position of the ventilation flaps. They must be opened to the maximum.
- Check the air filter(s) for dirt. If necessary, clean or replace the air filter(s).
- Check the minimum distance to walls or other objects. Position the device a little more in the room's centre if required.
- Check whether any windows and/or doors of the room are open. If so, close them. One window has to remain open for the exhaust air hose nonetheless.
- Check the temperature setting at the device. Reduce the set temperature if it is higher than the room temperature.

The device is loud or vibrates:

- Check whether the device is set up in a stable and upright position.

Condensate is leaking:

- Check the device for leaks.

The compressor does not start:

- Check whether the overheating protection of the compressor has tripped. Disconnect the device from the mains and let it cool down for approx. 10 minutes before reconnecting it.
- Check whether the ambient temperature equals the target temperature (in *cooling* mode). The compressor only switches on if the ambient temperature is higher than the target temperature.
- The compressor may start up with a delay of 3 minutes, as it is provided with an internal protection against direct restart.

The device gets very warm, is loud or is losing power:

- Check the air inlet and air filter for dirt. Remove external dirt.
- From the outside, check the device for dirt (see chapter Maintenance). If the inside of the device is dirty, have it cleaned by a specialist company for cooling and air-conditioning or by the manufacturer.

The device does not respond to the infrared remote control:

- Check whether the distance between remote control and device is too large and reduce it if necessary.
- Make sure there are no obstacles, such as furniture or walls, between the device and the remote control. Ensure visual contact between device and remote control.
- Check the charging status of the batteries and change them if required.
- If the batteries have just been changed, check them for correct polarity.
- Check whether the remote control is still in standby mode. Standby mode can be terminated by pressing the *ON/OFF* button (28) on the remote control.

The device still does not operate correctly after these checks:

Please contact the customer service. If necessary, bring the device to a specialist company for cooling and air-conditioning or to the manufacturer for repair.

Error codes

The following error messages can be displayed in the segment display (15):

Error code	Cause	Remedy
E1	Fault at temperature sensor	Disconnect the device briefly from the mains.
E2	Fault at humidity sensor	Should the error still be displayed after the restart, please contact the customer service.
E4	Fault at control panel	
P1	Condensation tank full	Empty the condensation tank. Should the error still be displayed, please contact the customer service.

Maintenance

Maintenance intervals

Maintenance and care interval	before every start-up	as needed	at least every 2 weeks	at least every 4 weeks	at least every 6 months	at least annually
Check air inlets and outlets for dirt and foreign objects and clean if necessary	X			X		
Clean the exterior		X				X
Visually check the inside of the device for dirt		X				X
Check the air filter for dirt and foreign objects and clean or replace if necessary	X		X			
Replace the air filter					X	
Check for damage	X					
Check the attachment screws		X				X
Test run						X
Empty the condensation tray and drain hose		X				

Maintenance and care log

Device type:

Device number:

Maintenance and care interval	1	2	3	4	5	6	7	8	9	10	11	12	13	14	15	16
Check air inlets and outlets for dirt and foreign objects and clean if necessary																
Check air inlets and outlets for dirt and foreign objects and clean if necessary																
Clean the exterior																
Visually check the inside of the device for dirt																
Replace the air filter																
Check the attachment screws																
Test run																
Empty the condensation tray and drain hose																
Comments																

1. Date: Signature:	2. Date: Signature:	3. Date: Signature:	4. Date: Signature:
5. Date: Signature:	6. Date: Signature:	7. Date: Signature:	8. Date: Signature:
9. Date: Signature:	10. Date: Signature:	11. Date: Signature:	12. Date: Signature:
13. Date: Signature:	14. Date: Signature:	15. Date: Signature:	16. Date: Signature:

Activities required before starting maintenance



Warning of electrical voltage

Do not touch the mains plug with wet or damp hands.

- Switch the device off.
- Disconnect the device from the mains by removing the mains plug from the socket. When doing so, be sure to hold the plug, not the cable.



Warning of electrical voltage

Tasks which require the device to be opened must only be carried out by authorised specialist companies or by the manufacturer.

Refrigerant circuit



Danger

Natural refrigerant propane (R290)!

H220 – Extremely flammable gas.

H280 – Contains gas under pressure; may explode if heated.

P210 – Keep away from heat, sparks, open flames and other ignition sources. No smoking.

P377 – Leaking gas fire: Do not extinguish, unless leak can be stopped safely.

P410+P403 – Protect from sunlight. Store in a well-ventilated place.

- The entire refrigerant circuit is a maintenance-free, hermetically sealed system and may only be maintained or repaired by specialist companies for cooling and air-conditioning or by the manufacturer.

Safety signs and labels on the device

Check the safety signs and labels attached to the device at regular intervals. Replace illegible safety signs!

Cleaning the housing

Clean the housing with a soft, damp and lint-free cloth. Make sure that no moisture enters the housing. Protect electrical components from moisture. Do not use any aggressive cleaning agents such as cleaning sprays, solvents, alcohol-based or abrasive cleaners to dampen the cloth.

Visual inspection of the inside of the device for dirt

1. Remove the air filter.
2. Use a torch to illuminate the openings of the device.
3. Check the inside of the device for dirt.
4. If you see a thick layer of dust, have the inside of the device cleaned by a specialist company for cooling and air-conditioning or by the manufacturer.
5. Put the air filter back in.

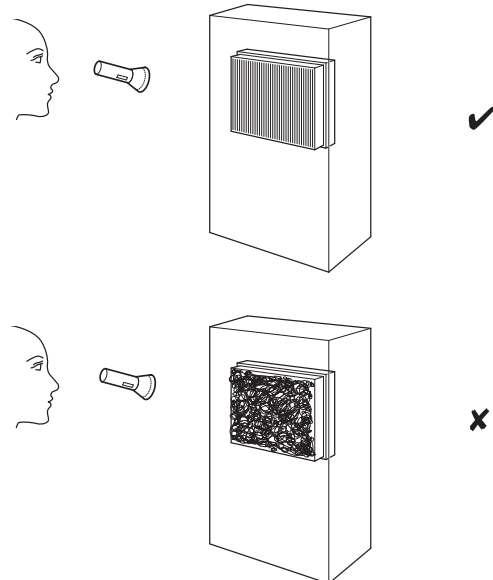

Cleaning the air filter

The air filter has to be cleaned as soon as it is dirty. This is brought to light e.g. by a reduced capacity (see chapter Errors and faults).



Warning

Ensure that the air filter is not worn or damaged. The corners and edges of the air filter must not be deformed or rounded. Before reinserting the air filter, make sure that it is undamaged and dry!

1. Remove the air filter from the device.

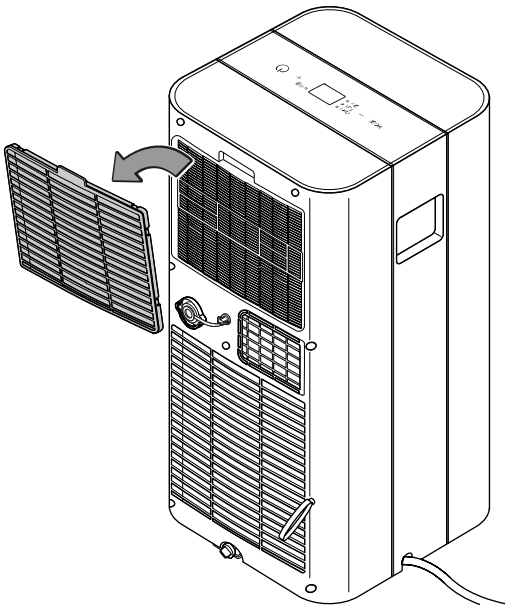

2. Clean the filter using a slightly damp, soft, lint-free cloth. If the air filter is heavily contaminated, clean it with warm water mixed with a neutral cleaning agent.
3. Allow the filter to dry completely. Do not insert a wet filter into the device!
4. Reinsert the air filter into the device.

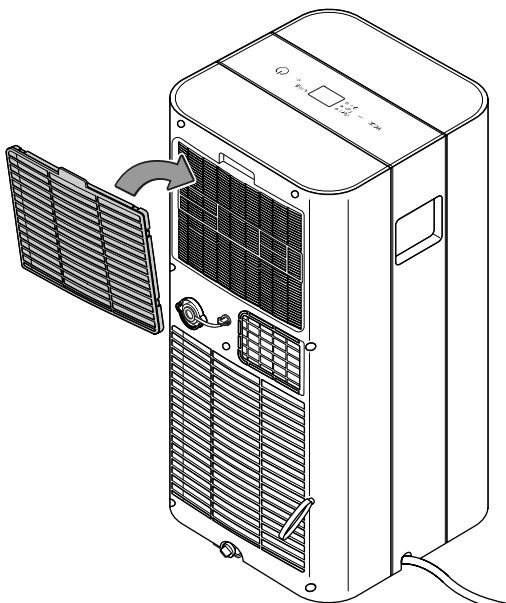

Condensate discharge (manual draining)

In *Cooling* and *Dehumidification* mode condensate is formed, which is mostly discharged via the exhaust air.

The remaining condensate is collected in a condensation tray within the housing. The condensate must be drained regularly. If too much condensate accumulates, the device switches off and indicates this via an acoustic signal and the *P1* indication on the segment display (15).

1. Check whether there is a drain at the installation site or provide a suitable collection container under the condensate outlet.

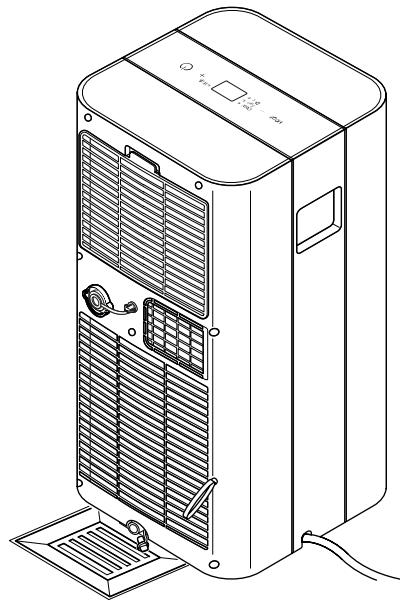

2. Remove the rubber stopper from the condensate outlet.

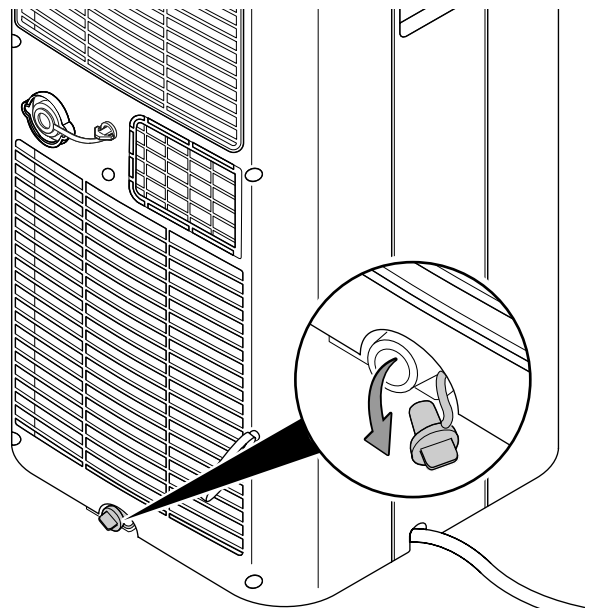

3. Drain the condensate.

4. Reattach the rubber stopper to the condensate outlet. Ensure the tight fit of the rubber stopper, for otherwise there might be uncontrolled water leakage.

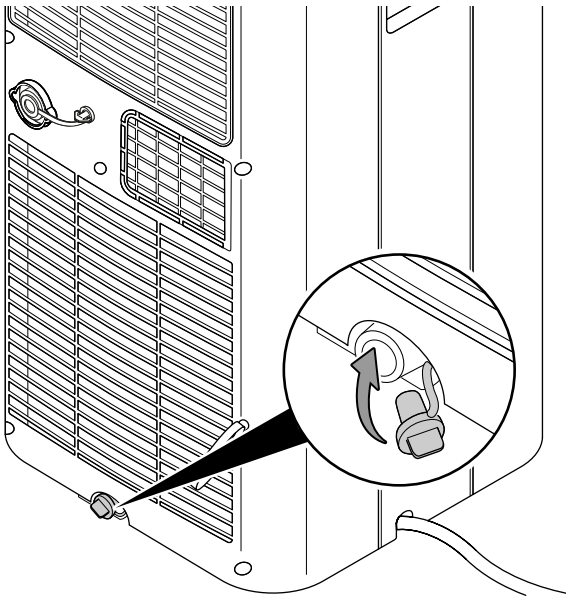

⇒ The *P1* error code on the segment display (15) will disappear as soon as the condensate has been drained.

Activities required after maintenance

If you want to continue using the device:

- Leave the device to rest for at least 12 hours, so the refrigerant can accumulate within the compressor. Wait 12 hours before switching the device back on! Acting contrary might lead to compressor damage and a malfunctioning device.
- Reconnect the device to the mains.

If you do not intend to use the device for a considerable time:

- Store the device according to the Transport and storage chapter.

Technical annex
Technical data

Model	PAC 2100 X	PAC 2600 X
Cooling capacity	2.0 kW	2.6 kW
Dehumidification performance	1.8 l/h	2.26 l/h
Operating temperature	17 °C to 35 °C	17 °C to 35 °C
Temperature setting range	17 °C to 30 °C	17 °C to 30 °C
Max. air volume flow	319 m ³ /h	295 m ³ /h
Fusing 	T 3.15 A / 250 V AC	T 3.15 A / 250 V AC
Type of protection	IPX0	IPX0
Mains connection	1/N/PE~ 220 V – 240 V / 50 Hz	1/N/PE~ 220 V – 240 V / 50 Hz
Nominal current	5.0 A	6.16 A
Power input (cooling operation)	0.96 kW	1.2 kW
Sound pressure level at a distance of 1 m	53 dB(A)	52 dB(A)
Refrigerant	R-290	R-290
Amount of refrigerant	0.13 kg	0.17 kg
GWP factor	3	3
CO ₂ equivalent	0.00039 t	0.00051 t
Suction side pressure	1.0 MPa	1.0 MPa
Pressure outlet side	2.6 MPa	2.6 MPa
Max. permissible pressure	2.6 MPa	4.8 MPa
Dimensions (length x width x height)	355 x 345 x 703 mm	355 x 345 x 703 mm
Minimum distance to walls and other objects:		
top (A):	30 cm	30 cm
rear (B):	30 cm	30 cm
sides (C):	30 cm	30 cm
front (D):	30 cm	30 cm
Weight	22.5 kg	25 kg
Remote control batteries	Type LR03 / AAA – 1.5 V (2 pcs.)	Type LR03 / AAA – 1.5 V (2 pcs.)

Circuit diagram

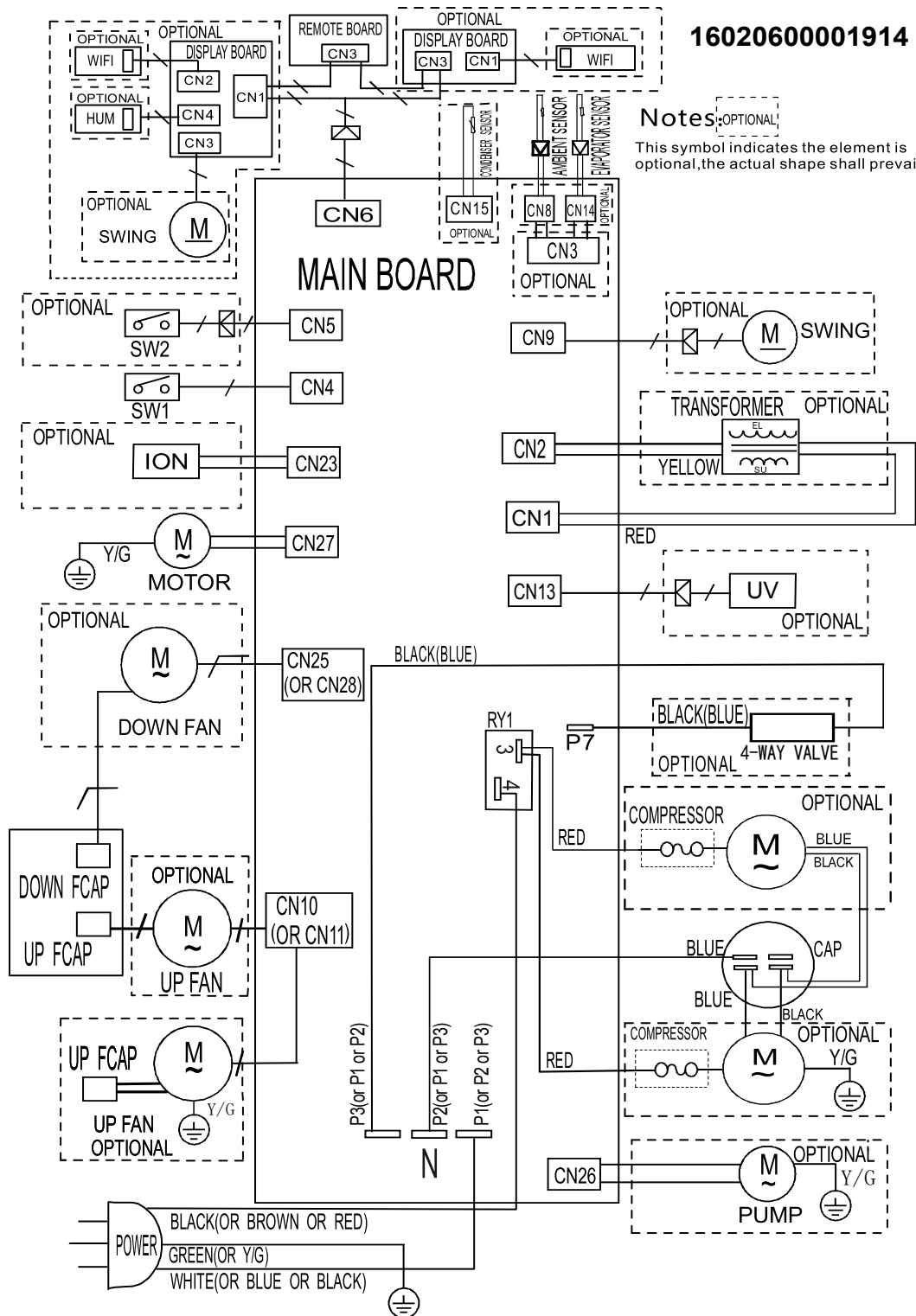

No.	Part Name	Quantity	No.	Part Name	Quantity
1	Front panel assembly	1	12.2	Shaded-pole Motor	1
4	Cover of electronic control box	1	12.3	Water wheel	2
5	Electronic control box subassembly	1	12.4	Water Level Switch	1
5.1	Fan Motor Capacitor	1	12.5	Power cord	1
5.2	Main control board subassembly	1	12.6	Drain Stopper	1
5.6	Electronic Control Box Subassembly	1	13	Cover of Drain connector(outdoor)	1
6	Capacitor box	1	14	Fixed Speed Rotary Compressor	1
7	Compressor Capacitor	1	15	Discharge pipe assembly	1
8	Air outlet volute shell assembly	1	16	Capillary assembly	1
8.1	Air exhaust volute shell subassembly	1	17	Evaporator Assembly	1
8.2	centrifuge fan	1	18	Condenser Assembly	1
8.3	Single Phase Asynchronous Motor	1	19	Suction pipe assembly	1
8.4	Cover subassembly of air exhause volute shell	1	20	Rear panel assembly	1
8.5	Air outlet volute shell	1	21	Connector, air exhaust duct	1
8.6	Air outlet volute shell	1	22	Exhaust Hose Subassembly	1
8.7	Sealing board	1	23	Drain Hose	1
8.8	Outdoor air inlet grille	1	24	Drain Hose Joint	1
8.9	Louver	1	26	Pipe Temperature Sensor	1
8.11	centrifuge fan	1	27	Room Temperature Sensor	1
9	inner side upper air duct subassembly	1	30	Drain Stopper	1
11	Supporting bar	2	32	Connector, Air Excaust Duct	1
12	Chassis assembly	1	33	Connector, Air Excaust Duct	1
12.1	Chassis subassembly	1	35	Indoor air inlet grille	1
12.1.1	Universal Wheel	4			

Overview of spare parts and spare parts list PAC 2600 X

Note: The position numbers of the spare parts differ from those describing the positions of other parts mentioned in this operating manual.

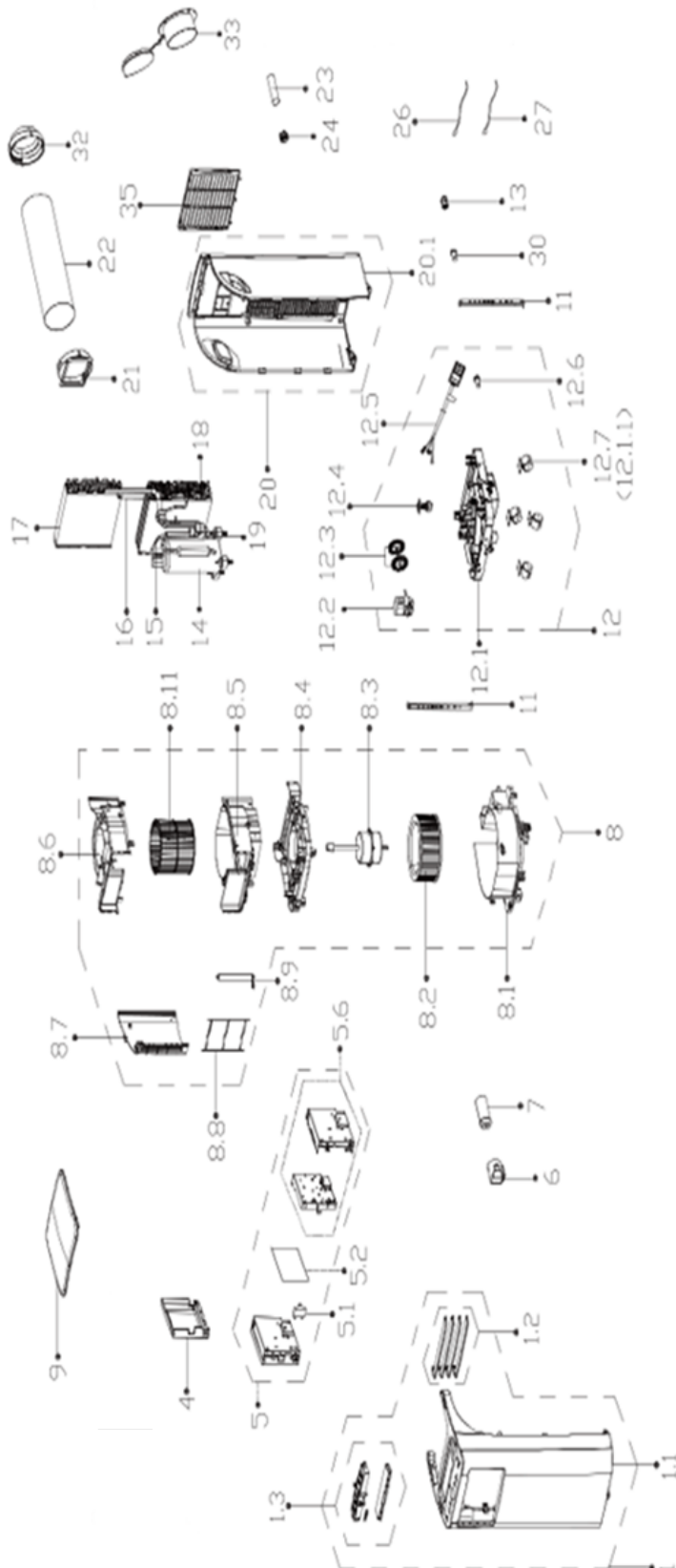

No.	Part Name	Quantity	No.	Part Name	Quantity
1	Front panel assembly	1	12.2	Shaded-pole Motor	1
4	Cover of electronic control box	1	12.3	Water wheel	2
5	Electronic control box subassembly	1	12.4	Water Level Switch	1
5.1	Fan Motor Capacitor	1	12.5	Power cord	1
5.2	Main control board subassembly	1	12.6	Drain Stopper	1
5.6	Electronic Control Box Subassembly	1	13	Cover of Drain connector(outdoor)	1
6	Capacitor box	1	14	Fixed Speed Rotary Compressor	1
7	Capacitor of compressor	1	15	Discharge pipe assembly	1
8	Air outlet volute shell assembly	1	16	Capillary assembly	1
8.1	Air exhaust volute shell subassembly	1	17	Evaporator Assembly	1
8.2	Centrifuge fan	1	18	Condenser Assembly	1
8.3	Single phase asynchronous motor	1	19	Suction pipe assembly	1
8.4	Cover subassembly of air exhause volute shell	1	20	Rear panel assembly	1
8.5	Air outlet volute shell	1	21	Connector, air exhaust duct	1
8.6	Air outlet volute shell	1	22	Exhaust Hose Subassembly	1
8.7	Sealing board	1	23	Drain Hose	1
8.8	Outdoor air inlet grille	1	24	Drain Hose Joint	1
8.9	Louver	1	26	Pipe Temperature Sensor	1
8.11	Centrifuge fan	1	27	Room Temperature Sensor	1
9	Upper panel	1	30	Drain Stopper	1
11	Supporting bar	2	32	Connector, Air Excaust Duct	1
12	Chassis assembly	1	33	Connector, Air Excaust Duct	1
12.1	Chassis subassembly	1	35	Indoor air inlet grille	1
12.1.1	Universal Wheel	4			

Disposal

Always dispose of packing materials in an environmentally friendly manner and in accordance with the applicable local disposal regulations.



The icon with the crossed-out wheeled bin indicates that this device and any associated components (e.g. remote controls) must not be disposed of with household waste at the end of their life, in accordance with the Waste Electrical and Electronic Equipment Directive (2012/19/EU) and national laws.

You will find collection points for free return of waste electrical and electronic equipment in your vicinity. The addresses can be obtained from your municipality or local administration. You can also find out about other return options that apply for many EU countries on the website <https://hub.trotec.com/?id=45090>. Otherwise, please contact an official recycling centre for electronic and electrical equipment authorised for your country.

The separate collection of waste electrical and electronic equipment aims to enable the re-use, recycling and other forms of recovery of waste equipment as well as to prevent negative effects for the environment and human health caused by the disposal of hazardous substances potentially contained in the equipment.



This icon with the crossed-out wheeled bin indicates that batteries or accumulators must not be disposed of with household waste at the end of their life. If the device contains batteries or accumulators that contain mercury, cadmium or lead, the respective chemical symbol (Hg, Cd or Pb) is shown below the icon of the crossed-out wheeled bin. To prevent environmental pollution, do not carelessly leave batteries or electrical and electronic equipment containing batteries in public areas. In the European Union, batteries and accumulators must be returned to a designated collection point in accordance with REGULATION (EU) 2023/1542 OF THE EUROPEAN PARLIAMENT AND OF THE COUNCIL of 12 July 2023 concerning batteries and waste batteries. Remove batteries/accumulators and dispose of them separately according to the relevant legal requirements.

Have the refrigerant (propane) disposed of appropriately and according to the national regulations by a company with the relevant certification (European Waste Catalogue 160504).

Only for United Kingdom

According to Waste Electrical and Electronic Equipment Regulations 2013 (SI 2013/3113) (as amended) and the Waste Batteries and Accumulators Regulations 2009 (SI 2009/890) (as amended), devices that are no longer usable must be collected separately and disposed of in an environmentally friendly manner.

Trotec GmbH

Grebbener Str. 7
52525 Heinsberg
Germany

☎ +49 2452 962-0

☎ +49 2452 962-200

✉ online@trotec.com

www.trotec.com