



Original instructions

AC 15000

| en |

Table of contents

Information on the use of these instructions	4
Signal words.....	4
Symbols.....	4
Safety	6
Intended use	8
Reasonably foreseeable misuse.....	8
Personnel qualification.....	8
Personal protective equipment.....	8
Safety signs and labels on the device	9
Residual risks	10
Behaviour in the event of an emergency	11
Information about the device	12
Device description.....	12
Device depiction.....	13
Transport and storage	15
Transport.....	15
Storage	16
Assembly and start-up	17
Scope of delivery	17
Unpacking the device.....	17
Start-up	17
Operation	22
Available accessories	34
Errors and faults	35
Maintenance	36
Maintenance intervals	36
Maintenance and care log.....	37
Safety instructions for maintenance	38
Safety signs and labels on the device	39
Cleaning the housing	39
Visual inspection of the inside of the device for dirt.....	39
Cleaning the air filter.....	40
Cleaning the heat exchanger of the outdoor unit.....	41
Checking and topping up the water / glycol mixture	42
Activities required after maintenance.....	43
Technical annex	44
Technical data	44
Disposal	59
EU Declaration of Conformity	60

Information on the use of these instructions

Signal words



Danger

This signal word indicates a hazard with a high risk level which, if not avoided, will result in serious injury or death.



Warning

This signal word indicates a hazard with an average risk level which, if not avoided, can result in serious injury or death.



Caution

This signal word indicates a hazard with a low risk level which, if not avoided, can result in minor or moderate injury.

Notice

This signal word indicates important information (e.g. material damage), but does not indicate hazards.

Symbols



Danger

This symbol indicates dangers to the life and health of persons due to flammable refrigerants.



Warning of sharp object

This symbol indicates dangers to the life and health of persons due to pointed objects.



Warning of electrical voltage

This symbol indicates dangers to the life and health of persons due to electrical voltage.



Info

Information marked with this symbol helps you to carry out your tasks quickly and safely.



Follow the manual

Information marked with this symbol indicates that the instructions must be observed.



Wear safety glasses

Information marked with this symbol indicates that you should wear eye protection.



Wear a protective mask

Information marked with this symbol indicates that you should wear a protective mask.



Wear protective gloves

Information marked with this symbol indicates that you should wear protective gloves.



Wear foot protection

Information marked with this symbol indicates that you should wear safety boots.

You can download the current version of these instructions via the following link:

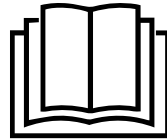

AC 15000



Safety

Read this manual carefully before starting or using the device. Always store the manual in the immediate vicinity of the device or its site of use.



Warning

Read all safety warnings and all instructions.

Failure to follow the warnings and instructions may result in electric shock, fire and/or serious injury.

Save all warnings and instructions for future reference.

This appliance can be used by children aged from 8 years and above and persons with reduced physical, sensory or mental capabilities or lack of experience and knowledge if they have been given supervision or instruction concerning use of the appliance in a safe way and understand the hazards involved.

Children shall not play with the appliance. Cleaning and user maintenance shall not be done by children without supervision.

- Do not use the device in potentially explosive rooms or areas and do not install it there.
- Do not use the device in an aggressive atmosphere.
- Place the device in an upright and stable position on a horizontal and stable surface.
- Never drink the water / glycol mixture! Dispose of the water / glycol mixture properly.
- Fill the tank with the water / glycol mixture only.
- Let the device dry out after a wet clean. Do not operate it when wet.
- Do not use the device with wet or damp hands.
- Do not expose the device to directly squirting water.
- Never insert any objects or limbs into the device.
- Do not cover the device during operation.
- Do not sit on the device.
- This appliance is not a toy. Keep away from children and animals.
- Check accessories and connection parts for possible damage prior to every use of the device. Do not use any defective devices or device parts.
- Ensure that all electric cables outside of the device are protected from damage (e.g. caused by animals). Never use the device if electric cables or the power connection are damaged!
- The mains connection must correspond to the specifications in the Technical annex.
- Insert the mains plug into a properly fused mains socket.
- Observe the technical data when selecting extensions to the power cable. Completely unroll the extension cable. Avoid electrical overload.
- Before carrying out maintenance, care or repair work on the device, remove the mains plug from the mains socket. Hold onto the mains plug while doing so.
- Switch the device off and disconnect the power cable from the mains socket when the device is not in use.
- Do not under any circumstances use the device if you detect damages on the mains plug or power cable.
If the supply cord is damaged, it must be replaced by a special cord or assembly available from the manufacturer or its service agent.
Defective power cables pose a serious health risk!
- When positioning the device, observe the minimum distances from walls and other objects as well as the storage and operating conditions specified in the Technical annex.

- Make sure that the air inlet and outlet are not obstructed.
- Do not remove any safety signs, stickers or labels from the device. Keep all safety signs, stickers and labels in legible condition.
- Use the transport handles of the outdoor unit and basic device only to wheel the devices. Never lift the devices at the transport handles, there is a risk of injury if the devices fall down.
- Check the outdoor unit and basic device for damage and corrosion at regular intervals.
- Discharge the collected condensate before transport and storage. Do not drink it. Health hazard!
- Only transport the device in an upright position.
- Only use original spare parts, for otherwise safe and functional operation cannot be ensured.
- Only install the device in compliance with the national installation regulations.
- Only install, operate and store the device AC 15000 in a room measuring more than 10 m².
- Store the device in a way that no mechanical damage can occur.
- The entire refrigerant circuit is a maintenance-free, hermetically sealed system and may only be maintained or repaired by specialist companies for cooling and air-conditioning or by the manufacturer.

Safety instructions for servicing the refrigerant circuit:

- Every person working with or at the refrigerant circuit must be able to provide a certificate of qualification issued by a body accredited by the industry, demonstrating their competence in the safe use of refrigerants based on a procedure well-known in the industry.
- Service work may only be carried out in accordance with the manufacturer's specifications. If maintenance and repair work require the support of additional persons, the person trained in handling flammable refrigerants shall continuously supervise the work carried out.
- Do not store the device together with ignition sources in rooms without ventilation.
- Do not use any means other than those recommended by the manufacturer for accelerating the defrosting process or cleaning the device.
- Do not drill into or burn.
- Please note that the refrigerant is odourless.
- Observe the national regulations for gas installations.
- Observe the maximum refrigerant capacity in the technical data.

Intended use

Only use the device for cooling or circulating indoor air whilst adhering to the technical data. Any use other than the intended use is regarded as misuse.

Reasonably foreseeable misuse

- Do not place the device on wet or flooded ground.
- Do not place any objects, e.g. clothing, on the device.
- Do not use the basic device outdoors.
- Never immerse the device in water.
- Do not make any unauthorised modifications, alterations or structural changes to the device.

Personnel qualification

The following requirements with regard to personnel qualifications must be met:

- Operators: Operators who use this device must have read and understood the manual.
- Specialist staff: Maintenance work may only be carried out by trained specialist staff.
- Refrigeration engineers: Work on the refrigeration cycle must only be carried out by refrigeration engineers.

Personal protective equipment



Wear safety glasses

For start-up, maintenance and troubleshooting always wear suitable safety glasses.



Wear a protective mask

For cleaning and maintenance tasks wear an appropriate protective mask.



Wear protective gloves

For start-up, maintenance and troubleshooting always wear suitable protective gloves.



Wear foot protection

For transportation, start-up, maintenance and troubleshooting always wear suitable foot protection.

Safety signs and labels on the device

Notice

Do not remove any safety signs, stickers or labels from the device. Keep all safety signs, stickers and labels in legible condition.



The following safety signs and labels are attached to the device:

WARNING • WARNUNG • ATTENTION

DE Das Gerät muss in einem Raum mit einer Grundfläche größer als 10m² aufgestellt, betrieben und gelagert werden.

EN Appliance shall be installed, operated and stored in a room with floor area larger than 10m².

FR L'appareil doit être installé, utilisé et entreposé dans une pièce avec une surface supérieure à 10m².



Follow the manual

This symbol indicates that the instructions must be observed.



Follow the repair manual

Disposal, maintenance and repair work of the refrigerant circuit may only be carried out in accordance with the manufacturer's specifications and by persons having a certificate of qualification. A corresponding repair manual is available from the manufacturer upon request.



Warning of a trip hazard

This symbol indicates a trip hazard.



Warning of sharp edges

This symbol indicates sharp edges on the device.



Warning of a tipping hazard

This symbol indicates a tipping hazard. Take down the hose packages before the device is unloaded or lifted with the forklift.



Warning of electrical voltage

This symbol indicates electrical voltage. Maintenance and repair work on live parts may only be carried out by an electrically skilled person.



Warning – Improper Lifting

Use the side-mounted transport handles only for pushing the device. Do not use the transport handles for lifting or as attachment/lifting points under any circumstances.

Residual risks



Danger

Refrigerant R454C!

H221 – Flammable gas.

H280 – Contains gas under pressure; may explode if heated.

P210 – Keep away from heat, sparks, open flames and other ignition sources. No smoking.

P377 – Leaking gas fire; Do not extinguish, unless leak can be stopped safely.

P381 – Eliminate all ignition sources if safe to do so.

P410 and P403 – Protect from sunlight. Store in a well-ventilated place.



Danger

Risk of injury from contact with glycol!

Contact with the escaping water / glycol mixture can cause severe eye irritation and internal injuries when swallowed (e.g. kidney damage).

Avoid contact with the water / glycol mixture.

Never drink the water / glycol mixture!

Always wear safety glasses, protective gloves and tight-fitting work clothing.

In case of contact with eyes: Rinse carefully with water for some minutes. Remove contact lenses, if applicable. Continue rinsing.

Remove any escaping liquid.

Observe the relevant safety data sheets.



Warning of electrical voltage

Work on the electrical components must only be carried out by an authorised specialist company!



Warning of electrical voltage

Before any work on the device, remove the mains plug from the mains socket!

Do not touch the mains plug with wet or damp hands.

Hold onto the mains plug while pulling the power cable out of the mains socket.



Warning

Dangers can occur at the device when it is used by untrained people in an unprofessional or improper way! Observe the personnel qualifications!



Warning

The device is not a toy and does not belong in the hands of children.



Warning

There is a danger of suffocation for children due to packaging material! Keep packaging films and parts away from children. There is a risk of death due to suffocation.

Notice

To avoid damages to the device, only transport and operate the device in an upright position! It must neither be tilted nor laid down!

Notice

Do not operate the device without an inserted air filter! Without the air filter, the inside of the device will be heavily contaminated. This could reduce the performance and result in damage to the device.

en

Behaviour in the event of an emergency

1. Switch the device off.
2. Disconnect the device from the mains by removing the mains plug from the socket.
When doing so, be sure to hold the plug, not the cable.
3. Do not reconnect a defective device to the mains.

Information about the device

Device description

The device's primary purpose is room cooling and spot cooling. Moreover, the device provides the possibility of circulating the room air. The device is operated via the control panel on the device. The device is an air conditioner with split cooling circuits. The refrigerant circuit of the basic device is self-contained. For the dissipation of warmth it is emitted via a heat exchanger to a second cooling circuit. A second circuit transports warmed water / glycol mixture to the outdoor unit to cool it down again. The refrigerant cools down the air coming from the room and in doing so absorbs the heat. The fan then supplies the cooled air into the room where the device is positioned. Accumulating condensate is discharged via a separate hose to the outdoor unit.

Device depiction

Basic device - front view

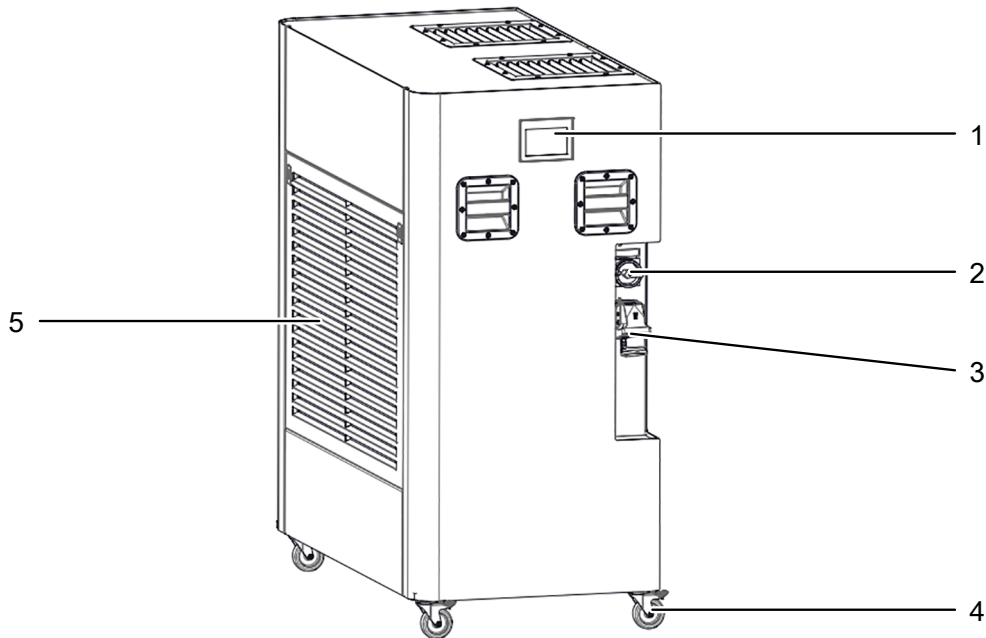

Basic device - rear view

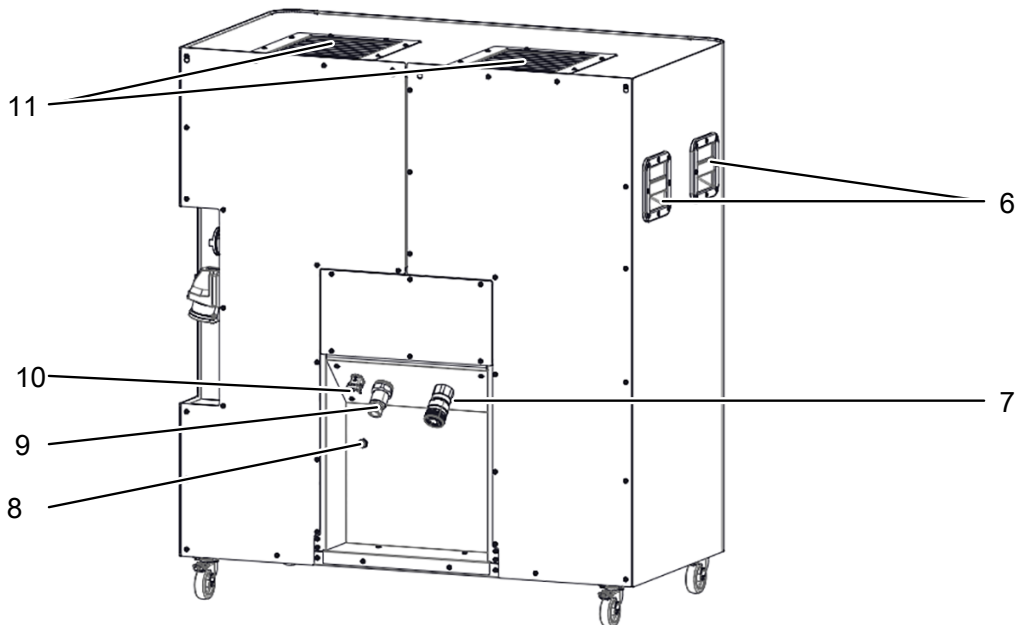

No.	Designation	No.	Designation
1	Control panel	7	Connection for line to basic device (IN)
2	Mains connection	8	Condensation drain hose connection
3	Main switch	9	Connection for line to basic device (OUT)
4	Wheels	10	Mains connection cable to outdoor unit
5	Air inlet with air filter	11	Air outlet
6	Transport handles		

**Outdoor unit -
front view**

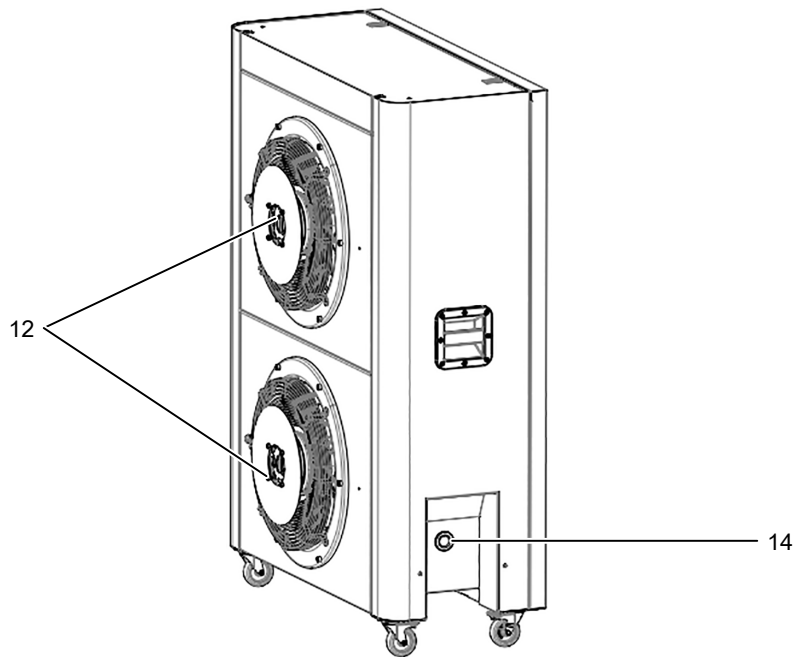

**Outdoor unit -
rear view**

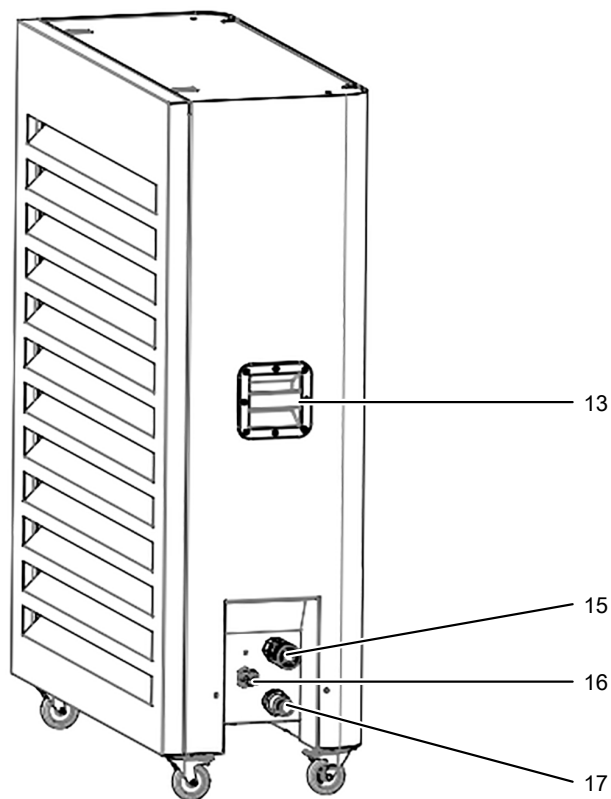

No.	Designation	No.	Designation
12	Fan	15	Cooling circuit connection to basic device (OUT)
13	Transport handle	16	Mains connection outdoor unit
14	Service opening for the pump	17	Cooling circuit connection to basic device (IN)

Transport and storage

Notice

If you store or transport the device improperly, the device may be damaged.
Note the information regarding transport and storage of the device.

Transport

Warning

Risk of injury by the device toppling over

You may suffer injuries if the device topples over.

- Do not lean against the device.
- Note the information regarding transport and storage of the device.

Warning

Risk of injury by toppling hose packages

You may suffer injuries if hose packages topple over.

- Take down the hose packages before the device is unloaded or lifted with the forklift.

Caution

Risk of injury by heavy device parts

The hose packages are heavy. Only carry and assemble the hose packages separately, since otherwise there is a risk of injury.

Notice

Use the transport handles attached to the sides only for wheeling the device.
Never use the transport handles for lifting or as a fixing / attachment point.



Wear foot protection

For transportation, start-up, maintenance and troubleshooting always wear suitable foot protection.

Please note that additional transport regulations might apply to devices containing flammable refrigerants. The equipment's arrangement and the maximum number of components to be transported together can be gathered from the applicable transport regulations.

Before transporting the device, observe the following:

- Take the device out of operation (see Operation chapter).
- Allow the water / glycol mixture to cool down.
- Release the brakes on the transport castors (6).

While transporting the device, observe the following:

- Do not use the power cable to drag the device.
- Transport the device in an upright position.
- The basic device is positioned on four movable transport castors and can be rolled by one person. The transport handles (2) attached to the side can be used to hold on to when rolling the device. Only roll the device on a level and smooth surface. If you want to lift and transport the device with a pallet jack or forklift, seek assistance from at least one other person.
- The outdoor unit can be wheeled by one person by means of the transport handle (15).

After transporting the device, proceed as follows:

- Set up the device in an upright position after transport.
- Apply the brakes on the transport castors (6) again.

Storage

Before storing the device, proceed as follows:

- Take the device out of operation (see Operation chapter).

When the device is not being used, observe the following storage conditions:

- Only store the device in a room measuring more than 10 m².
- Store the appliance in a room without continuously operating open flames (for example an operating gas appliance) or other potential ignition sources (for example an operating electric heater, hot surfaces);
- Store the device in a dry location and protected from frost and heat.
- Store the device in an upright position where it is protected from dust and direct sunlight.
- If required, use a cover to protect the device from invasive dust.
- The device is pressurized. Do not store the device over 70°.
- Place no further devices or objects on top of the device to prevent it from being damaged.

Assembly and start-up



Caution

Trip hazard due to hose packages

Install the hose packages so that no tripping hazards are created!

Scope of delivery

- 1 x Basic device
- 1 x Outdoor unit
- 1 x Hose set 10 m (incl. 1 x condensation hose, 2 x hose for the water / glycol circuit, 1 x electrical connection cable for the basic device to the outdoor unit)
- 1 x Manual

Unpacking the device

1. Open the package and remove the outdoor unit and the basic device.
2. Remove the packaging completely from the outdoor unit and the basic device.
3. Remove the hose set. Ensure that the basic device, outdoor unit, cables and hoses are not damaged.

Start-up



Info

Depending on the type of installation (stationary or mobile), the noise impact may vary. In the case of stationary installation (outdoor unit), suitable measures for vibration and noise decoupling must be provided for. In the case of mobile operation (basic device), the device must be installed so that persons are not bothered by noise unnecessarily.

When positioning the device, observe the minimum distance from walls or other objects as described in the Technical data chapter.

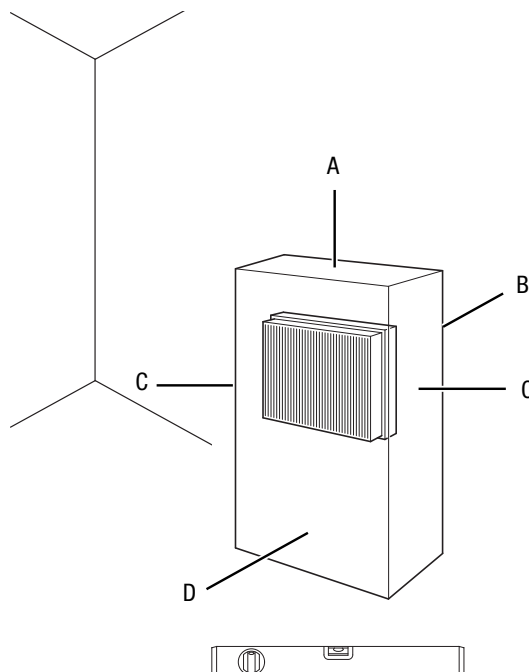

Installing the basic device

Before installing the device, observe the following:

- Only position the device in rooms where potentially leaking refrigerant cannot accumulate.
- Before restarting the device, check the condition of the power cable. If there are doubts as to the sound condition, contact the customer service.
- Place the device in an upright and stable position on a horizontal and stable surface.
- Check whether the brakes on the transport castors of the basic device (6) are engaged.
- Do not create tripping hazards when laying the power cable or other electric cables, especially when positioning the device in the middle of the room. Use cable bridges.
- Make sure that extension cables are completely unrolled.
- Ensure that the air inlet and outlet are not obstructed.
- Make sure that no curtains or other objects interfere with the air flow.

Installing the outdoor unit

Notice

Please note that the outdoor unit requires a minimum distance of 3 m to the front from the nearest wall or other objects.

Notice

During operation, the outdoor unit should be either lower or a maximum of 8 metres higher than the basic device. When refilling the water / glycol mixture, the outdoor unit must be placed either in a lower position or at the same level as the basic device.

Before installing the device, observe the following:

- Place the device in an upright and stable position on a horizontal and stable surface.

Inserting the air filter

Notice

Do not operate the device without an inserted air filter! Without the air filter, the inside of the device will be heavily contaminated. This could reduce the performance and result in damage to the device.

1. Press the two locking latches (18) downwards and hinge down the air inlet plate towards the front.
 - ⇒ The air inlet plate is held in position by two rebound straps.
2. Check whether the air filter (19) has already been inserted.
3. If the air filter (19) has not been inserted yet, place the air filter (19) in the designated recess.
4. Fold the air inlet plate up again.
 - ⇒ The locking latches (18) engage automatically and lock the air inlet plate.

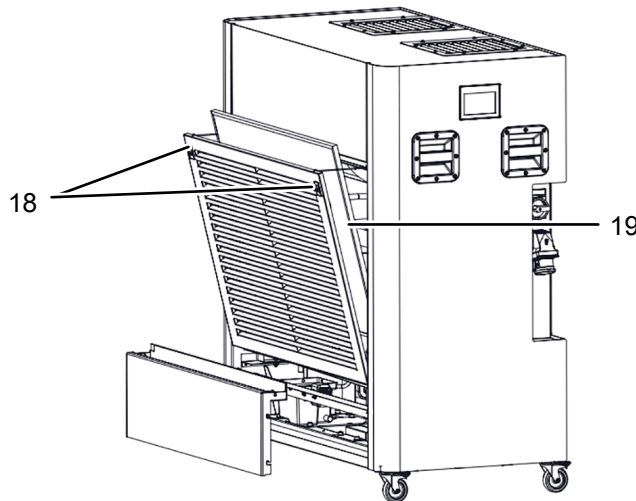

Removing the service flap

1. Press the two locking latches (18) downwards and hinge down the air inlet plate towards the front.
 - ⇒ The air inlet plate is held in position by two rebound straps.
2. Loosen the rebound straps at the air inlet plate and draw the air inlet plate upwards out of the fixtures.
3. Press the two lock buttons (21) inwards and lift the service flap (20) out.

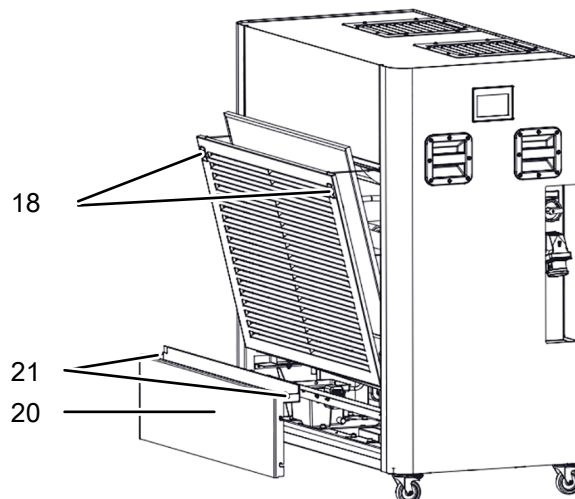

Connecting basic device and outdoor unit

⚠ Caution

Couplings/actuation point of the quick-release locks for the air conditioning unit can reach increased temperatures during operation.

- When decommissioning and disassembling the basic device and outdoor unit, do not touch the couplings before a cool-down period of 15 minutes has elapsed.

Notice

If the basic device and outdoor unit are installed on a sensitive surface, protect it with appropriate covers during installation.



Wear safety glasses

When carrying out the commissioning process, wear suitable eye protection to prevent eye injuries.



Wear protective gloves

When carrying out the commissioning process, wear suitable protective gloves to prevent hand injuries.



Info

Both the basic device and the outdoor unit are equipped with flat-face couplings. This allows for leakage-free coupling and decoupling.



Info

The hose set is 10 metres long. You can use a maximum of 3 hose sets and thus extend the length to 30 metres. The electrical connection cable for the basic device and outdoor unit is also 10 metres long.

Connections on the outdoor unit

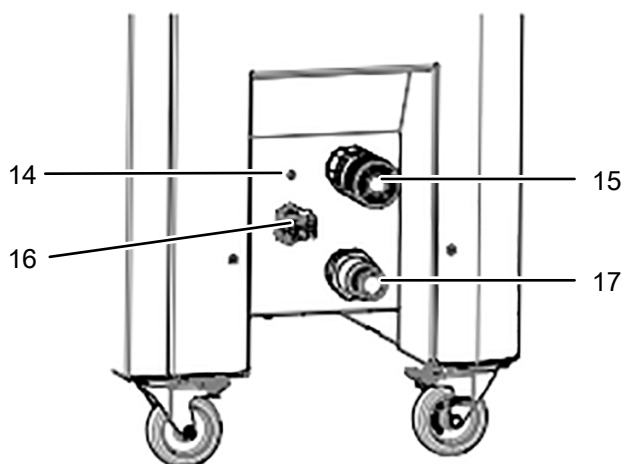

Connections on the basic device

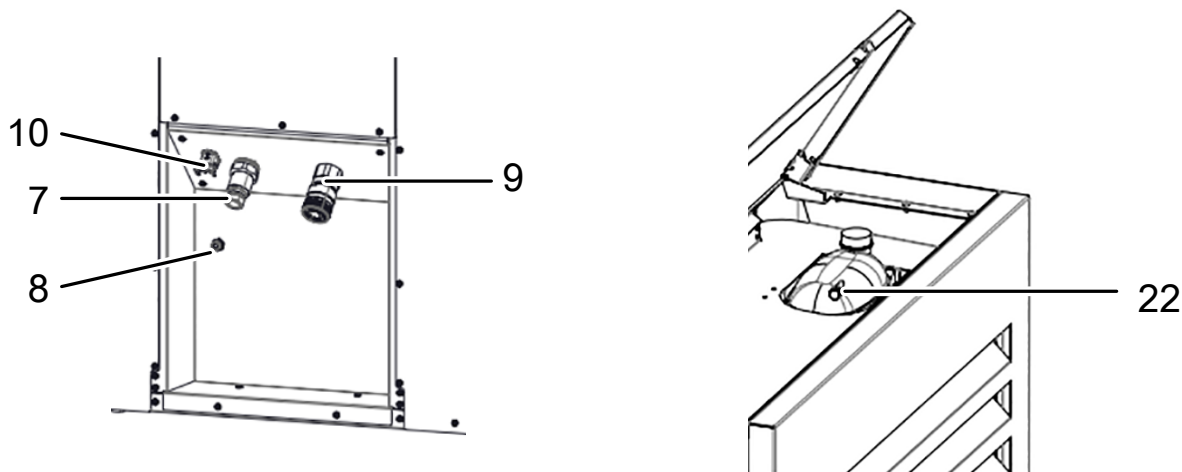

1. Insert the condensation drain hoses supplied into the connection provided on the outdoor unit (14) and the connection on the basic device (8).
2. Guide the other hose ends to an individual drain or sufficiently dimensioned collection container.
 - ⇒ Make sure that the hose is not kinked and that it does not face an incline on the way to the drain, as otherwise the condensate cannot drain off.
3. Connect the outdoor unit and the basic device by plugging the connection cable into the connections (10 and 16).
4. Connect the outdoor unit and the basic device by connecting the hoses from the supplied hose set to the IN and OUT connections (connections 7 and 17 as well as connections 9 and 15).
5. Remove the lid of the tank and check whether the tank (22) is sufficiently filled with liquid.
 - ⇒ The fill level indicator (round small plate) must be slightly covered with refrigerant in cold condition.
6. Check the glycol content with an antifreeze tester as specified in the technical data. If necessary, refill the tank with the water/glycol mixture (see Checking and refilling the water/glycol mixture, Maintenance chapter).
7. After the installation, allow the device to rest for 2 hours before switching it on.

Connecting the power cable



⚠ Warning of electrical voltage

Do not touch the mains plug with wet or damp hands.
 Hold onto the mains plug while plugging the power cable into the mains socket.
 Do not operate the device while the housing is removed!

1. Plug the power cable into the mains connection (2) of the basic device.
2. Insert the mains plug into a properly fused mains socket.

Operation

Notice

If the device has been transported, allow it to stand for 30 minutes before using it again so that the lubricating oil can flow back into the compressor. Acting contrary might lead to compressor damage and a malfunctioning device.



Info

Avoid open doors and windows so that the cooling function of the basic device is not impaired.

Switching the device on

Once you have completely installed the device as described in the Start-up chapter, you can switch it on.

Please proceed as follows to switch the device on:

1. Set the main switch (4) to position I.



⇒ The control panel lights up and the device initialises automatically while displaying the following:

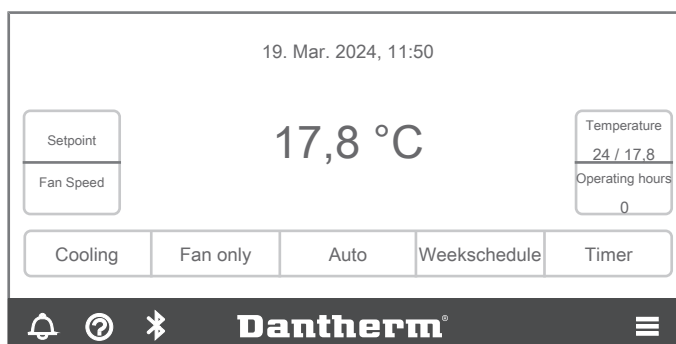

⇒ The main screen appears after 30 seconds.



Basic settings

- The temperature displayed in the centre of the main screen is the actual value (ambient value). The temperature, the setpoint and the current actual value are displayed on the right side of the main screen.
- Press the  icon on the main screen to display all current and previous settings and warning messages. New messages are displayed directly next to the  icon with a yellow dot.
- Press the  icon on the main screen to display the contact data of the manufacturer, which you can use to contact the customer service.
- Some inputs must be activated by pressing the *Save* or *Back* button. When using the *Back* button, the settings are only saved if the *Save* button is not available. The display will be dimmed if it is not actuated for a certain time. This function can be deactivated in the *Preferences* menu.
- Settings that have been made but not confirmed with *Save* or *Back* are not saved.

Setting the language, date and time

Please proceed as follows to set the language, day and time:

1. Press the  icon on the main screen.
⇒ The display changes to the following submenu.

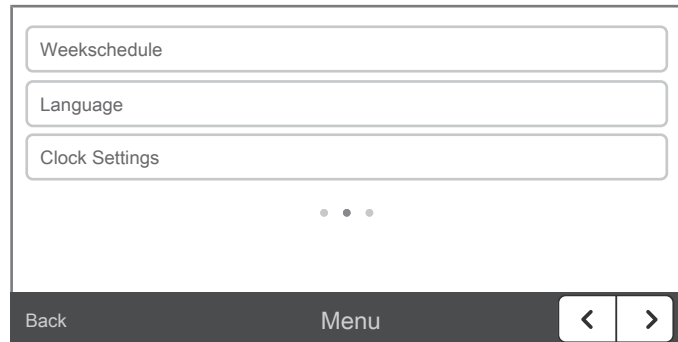

2. Press the *Language* button.
⇒ The display changes to the *Language* menu.
⇒ A language is already preselected.
3. Press the button for the desired language to select it.
⇒ You can select the languages German, English, French, Spanish or Italian.
⇒ The *Save* button appears.



4. Press the *Save* button to save the setting.

⇒ The display changes to the following submenu.

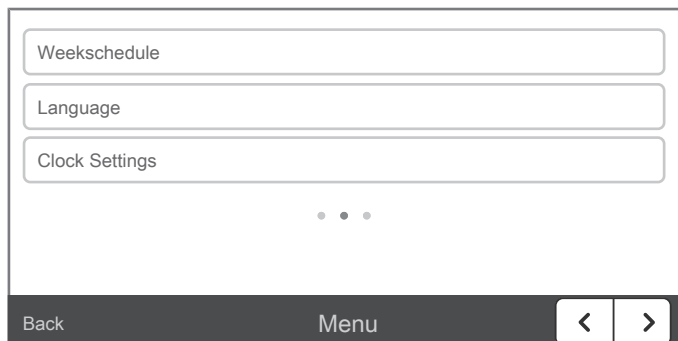

5. Press the *Clock settings* button.

⇒ The display changes to the *Clock settings* menu.

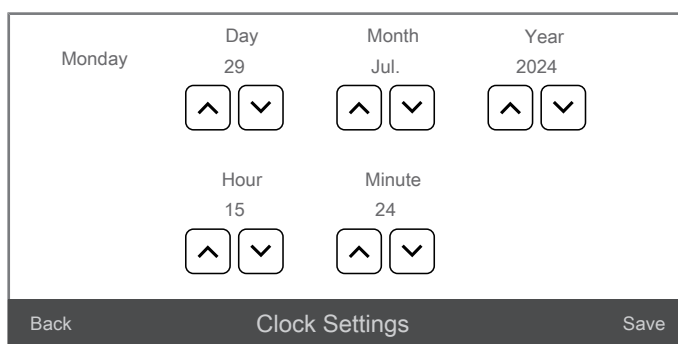

6. Press the  icon (*decrease value*) or the  icon (*increase value*) to set the day, month, year, hour and minute.

7. Press the *Save* button.

⇒ The basic settings have now been made.

8. Press the *Back* button to return to the main screen.

Temperature setting

1. Press the *Setpoint* button.

⇒ The selected button is highlighted in grey.



2. Press the - or + button to adjust the desired temperature setpoint.

⇒ After a short time, the actual value is shown again in the centre of the display. The setpoint and actual value are still displayed on the right-hand side in the Temperature field.

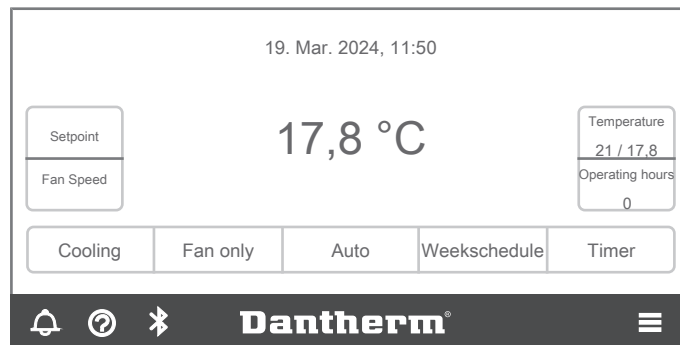

Setting the fan speed

1. Press the *Fan Speed* button on the main screen.

⇒ The selected button is highlighted in grey.

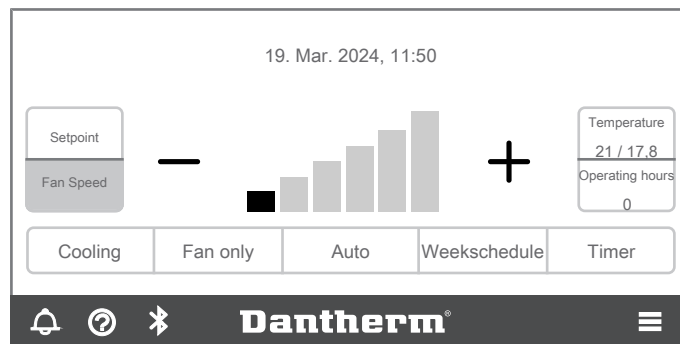

2. Press the - or + button to set the desired fan speed.

⇒ The activated fan level can be read from the black bars. One bar stands for one fan stage each.

Speed 1 corresponds to 1050 m ³ /h	Speed 4 corresponds to 2750 m ³ /h
Speed 2 corresponds to 2250 m ³ /h	Speed 5 corresponds to 3000 m ³ /h
Speed 3 corresponds to 2500 m ³ /h	Speed 6 corresponds to 3650 m ³ /h

Setting the operating mode

The device comes with three different operating modes: cooling, ventilation and automatic mode.

Please proceed as follows to set the operating mode:

1. Press the *Cooling* button on the main screen.

- ⇒ The selected button is highlighted in grey.
- ⇒ The icon for *Cooling* mode appears at the top right of the display.

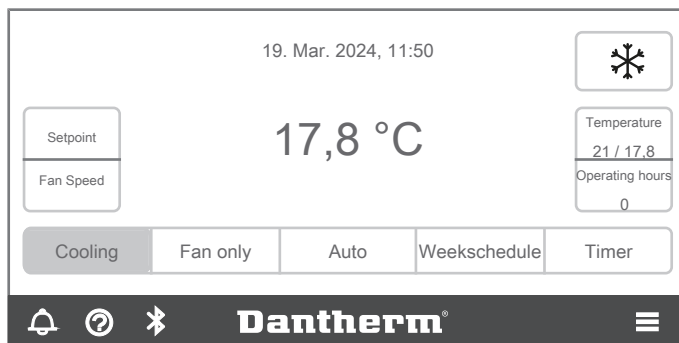

- ⇒ The air is cooled to the temperature set in the *Setpoint* field. The previously set fan speed is also activated. The device will switch to standby mode.

2. Press the *Fan only* button on the main screen.

- ⇒ The selected button is highlighted in grey.
- ⇒ The icon for *Fan only* mode appears at the top right of the display.

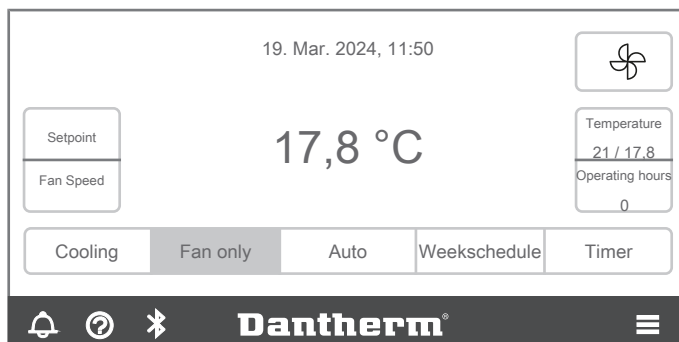

- ⇒ The air is not cooled, but circulated at the selected fan speed. The water circuit to the outdoor unit is switched off in this case.

3. Press the *Auto* button.

- ⇒ The selected button is highlighted in grey.
- ⇒ The icon for automatic mode only mode appears at the top right of the display.

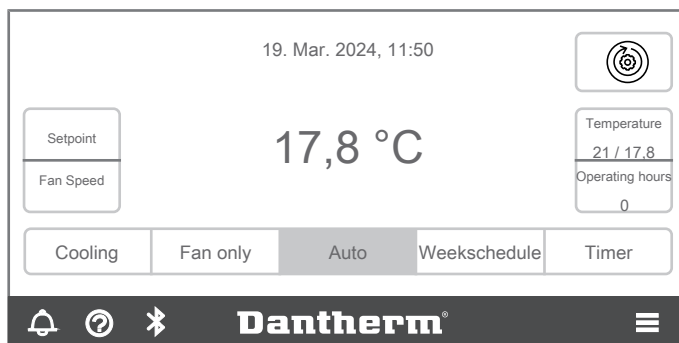

- ⇒ The air is cooled to the temperature set in the *Setpoint* field. The cooling capacity and fan performance are set automatically depending on the actual temperature.

Setting a weekly schedule

1. Press the ☰ icon on the main screen.

⇒ The display changes to the following submenu.

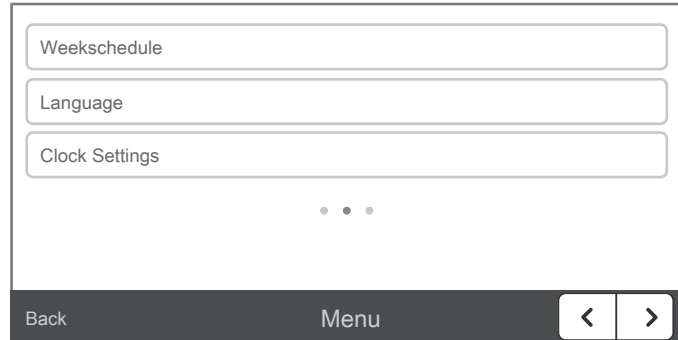

2. Press the *Weekschedule* button.

⇒ The display changes to the *Weekschedule* submenu.

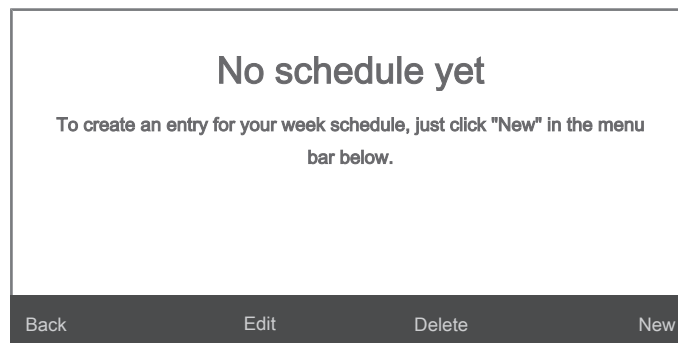

3. Press the *New* button to create a new weekly schedule.

⇒ The display changes to the *Switching Time* submenu.



4. Press the *Weekschedule* button.

⇒ The display changes to the *Day* menu.

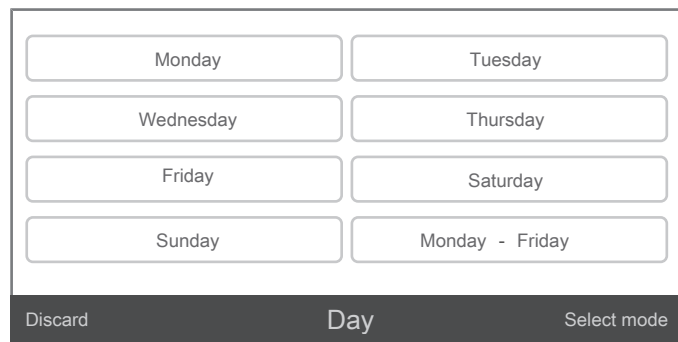

5. Press the desired day of the week to activate it.

⇒ The button is highlighted in grey.

6. Press the *Select mode* button to confirm the entry.

⇒ The display changes to the *Switching Time* menu again.



The screenshot shows the 'Switching Time' menu. It features four input fields: 'Weekschedule' set to 'Monday', 'Fan level' set to 'Level 1', 'Setpoint' set to '21 °C', and 'Time' set to '12:00'. At the bottom, there is a dark bar with three buttons: 'Cancel', 'Switching Time', and 'Save'.

7. Press the *Fan level* button to set the desired level.

⇒ The display changes to the *Fan Level* menu.

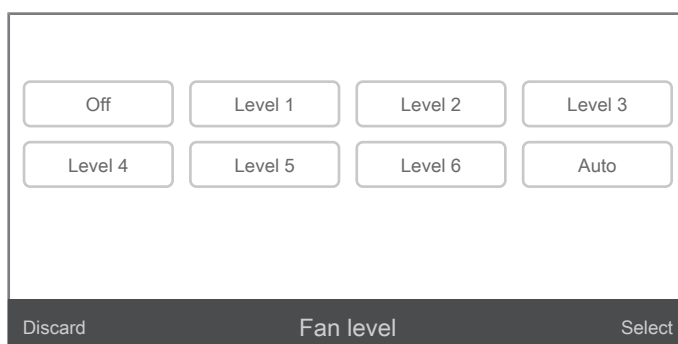

The screenshot shows the 'Fan level' menu. It contains eight buttons arranged in two rows: 'Off', 'Level 1', 'Level 2', 'Level 3' in the first row, and 'Level 4', 'Level 5', 'Level 6', 'Auto' in the second row. The 'Level 1' button is highlighted in grey. At the bottom, there is a dark bar with three buttons: 'Discard', 'Fan level', and 'Select'.

⇒ Press the *Level 1 – Level 6* button (activation of a fan level), the *Auto* button (activation of automatic mode) or the *Off* button (ventilation is deactivated).

⇒ The selected button is highlighted in grey.

8. Press the *Select* button to confirm the entry.

⇒ The display changes to the *Switching Time* menu again.



This screenshot is identical to the one in step 6, showing the 'Switching Time' menu with 'Weekschedule' (Monday), 'Fan level' (Level 1), 'Setpoint' (21 °C), and 'Time' (12:00). The bottom bar contains 'Cancel', 'Switching Time', and 'Save' buttons.

9. Press the *Setpoint* button.

⇒ The display changes to the *Setpoint* menu.

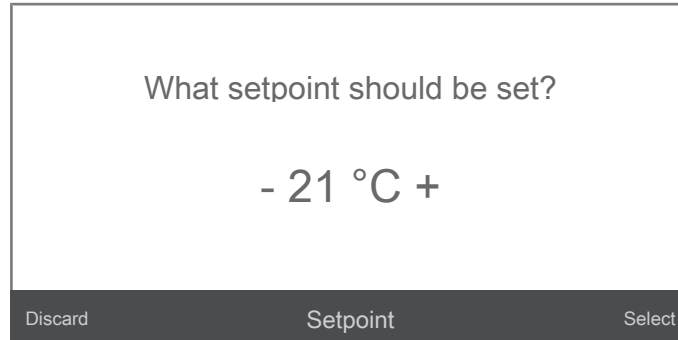

10. Press the - or + button to adjust the desired temperature setpoint.

11. Press the *Select* button to save the entry.

⇒ The display changes to the *Switching Time* menu again.



12. Press the *Time* button.

⇒ The display changes to the *Time* menu.

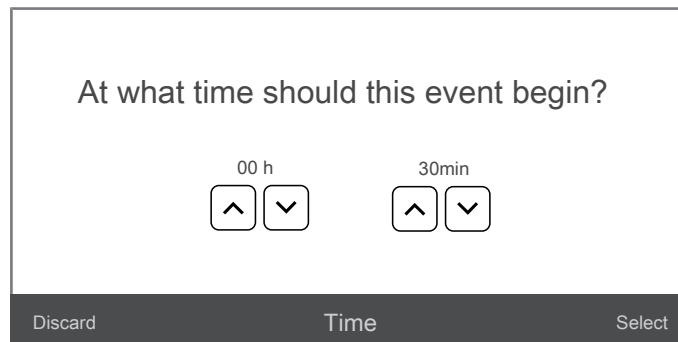

13. Press the icon (*decrease value*) or the icon (*increase value*) to set the hours, minutes and seconds.

14. Press the *Select* button to confirm the entry.

⇒ Ventilation mode with the set fan speed and automatic mode start at the set time.

⇒ The display changes to the *Switching Time* menu again.

15. Press the *Save* button.

16. Press the *Back* button until you have returned to the main screen.

Activating the locking function

The locking function prevents the buttons on the control panel from being used. Proceed as follows to set your own PIN:

1. Press the ☰ icon on the main screen.

⇒ The display changes to the following submenu.

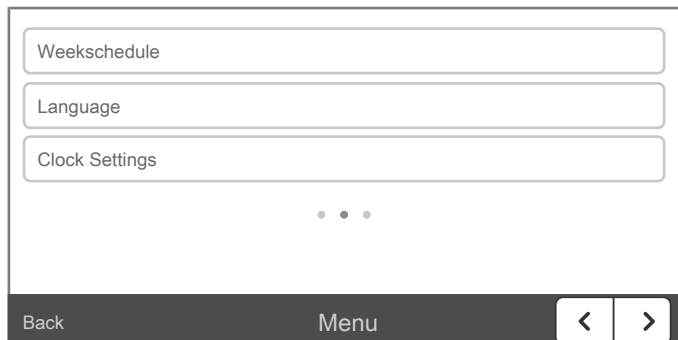

2. Press the < > icon (next/back).

3. Press the *Lock settings* button.

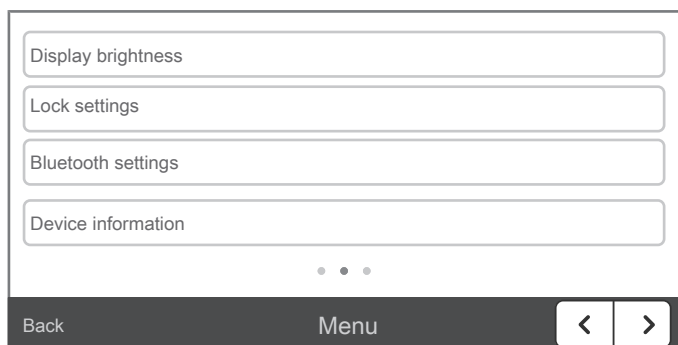

⇒ The display changes to the *Lock settings* menu.

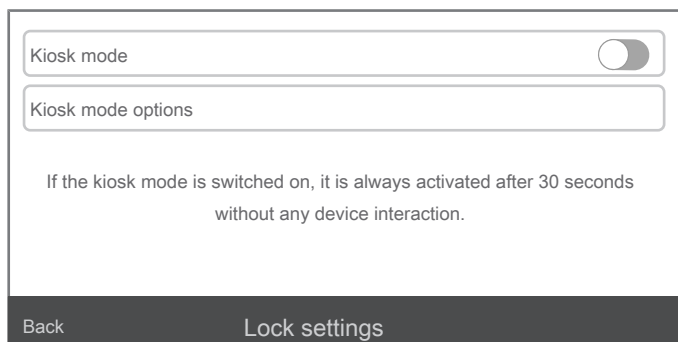

4. Press the *Kiosk mode* button.

⇒ The display changes to the submenu for creating the PIN.

5. Then press the empty button and create a 5-digit PIN in the subsequent menu.

6. Press the *OK* button and then *OK* again.

⇒ The screen lock is activated and the device can no longer be operated.

⇒ The 🗝 icon appears at the bottom right of the main screen.

Activating the locking function for certain functions

Please proceed as follows if you want to activate the PIN for certain functions only:

1. Press the *Kiosk mode options* button on the *Lock settings* screen.
 - ⇒ The display for entering the PIN appears.
2. Enter your PIN.
 - ⇒ The display changes to the *Kiosk mode options* menu.

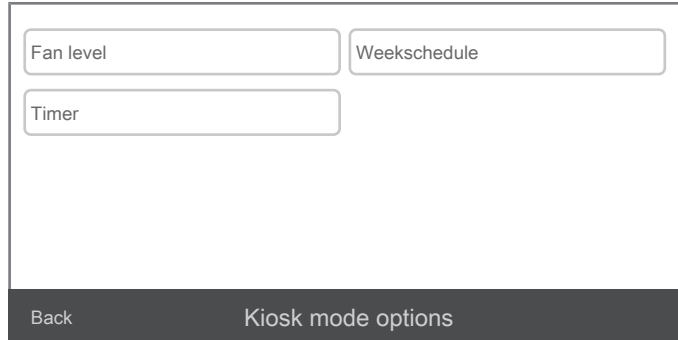

3. Press the desired button to deactivate the function or setting.
 - ⇒ The selected button is highlighted in grey.

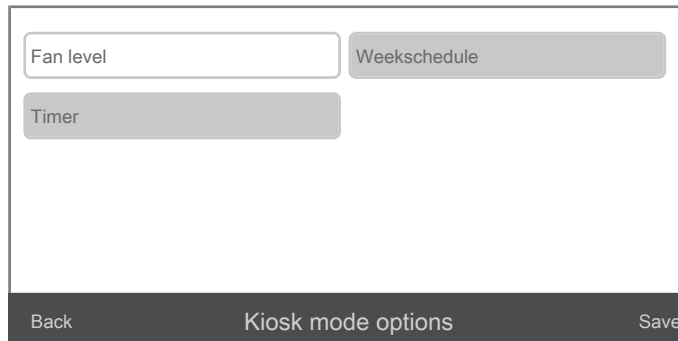

4. Press the *Save* button to activate the locking function for the selected function or setting.
 - ⇒ The locking function remains activated even if the device is switched off and on again.



Info

You can disable the locking function for a function by pressing the activated button and then pressing the *Save* button.

Restoring the default settings after a power failure

When the power is switched on again after a power failure, the device is in standby mode after switch-on and the default settings are used. Please proceed as follows to reactivate the settings used before the power failure:

1. Press the ☰ icon on the main screen.

⇒ The display changes to the following submenu.

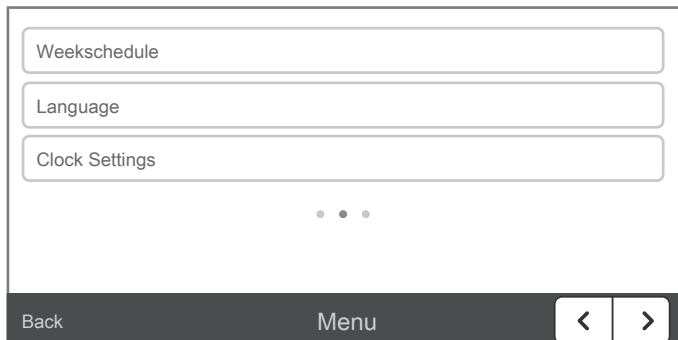

2. Press the < > icon (next) twice.

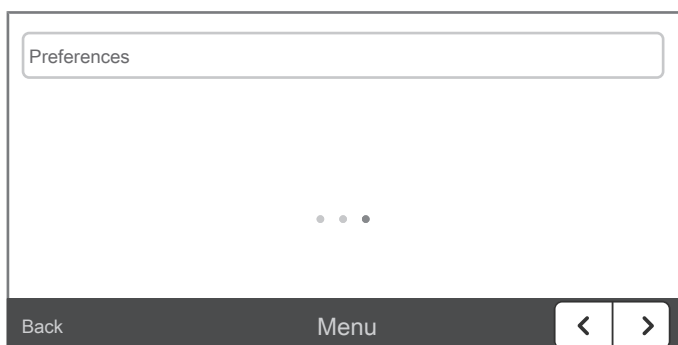

3. Press the *Preferences* button.

⇒ The display changes to the *Preferences* menu.

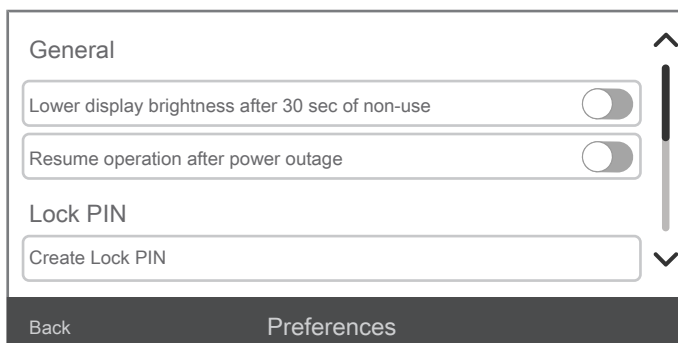

4. Press the *Resume operation after power outage* button.

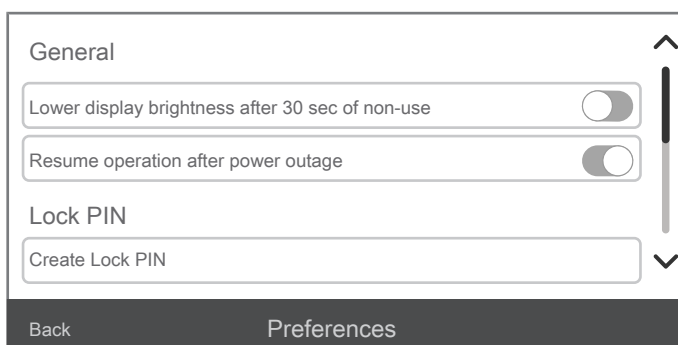

5. Press the *Back* button until you have returned to the main screen.

Automatic defrosting

At low ambient temperatures, ice may form at the vaporizer during air conditioning.

The device will perform automatic defrosting. The icon is shown at the top right of the control panel display (1) and the *Cooling* button is highlighted in grey. The device is now in defrosting mode. In this process, hot refrigerant is led into the iced evaporator for its surfaces to defrost. Automatic defrosting cannot be activated or deactivated manually.

The duration of defrosting can vary. The automatic defrost system integrated in the device automatically switches on the defrost cycle at regular intervals.

Do not switch off the device during automatic defrosting. Do not remove the mains plug from the mains socket.

After automatic defrosting the device keeps running for approx. 90 seconds for the purpose of air circulation – regardless of the ambient temperature and the desired room temperature. Afterwards the device resumes operation with the set values.

Notice

Do not scrape off any ice. At low room temperatures, usually below 15 °C, ice can form inside the basic device, for example on the vaporizer, which is located behind the air filter. In this case, also wait for the automatic defrosting process to be completed. If defrosting could not be completed (residual ice formation), please contact customer service.

Shutdown

Warning of electrical voltage

Do not touch the mains plug with wet or damp hands.

Caution

Couplings/actuation point of the quick-release locks for the air conditioning unit can reach increased temperatures during operation.

- When decommissioning and disassembling the basic device and outdoor unit, do not touch the couplings before a cool-down period of 15 minutes has elapsed.
- Remove the condensate from the basic device. To do so, set a setpoint for the temperature that is higher than the actual room temperature (see Operation chapter) and allow the device to run for 3 minutes with this setting. The condensate is channelled to the outdoor unit and evaporates.
- Switch off the device by setting the main switch (4) to position **0**.
- Disconnect the device from the mains by removing the mains plug from the socket. When doing so, be sure to hold the plug, not the cable.
- If required, clean the device according to the "Maintenance" chapter.
- Store the device according to the Transport and storage chapter.

Available accessories



Designation	Article number
Hose set 10 m extension	
AC 15000 outdoor unit	
Glycol	
Spot cooling	
Duct cooling	

Errors and faults

The device has been checked for proper functioning several times during production. If malfunctions occur nonetheless, check the device according to the following list.



Wear safety glasses

For start-up, maintenance and troubleshooting always wear suitable safety glasses.



Wear protective gloves

For start-up, maintenance and troubleshooting always wear suitable protective gloves.

The device does not start:

- Check the power connection.
- Check the power cable and mains plug for damage. If you notice damages, do not try to take the device back into operation. If the supply cord is damaged, it must be replaced by the manufacturer, its service agent or similarly qualified persons in order to avoid a hazard.
- Check the on-site fusing.
- Observe the operating temperature according to the chapter Technical annex.
- If the device is not starting, have the electrics checked by a specialist company or by the manufacturer.

The device works with reduced or no cooling capacity:

- Check whether *Cooling* mode or automatic mode is selected.
- Check the air filter for dirt. If necessary, clean or replace the air filter.
- Check the minimum distance to walls or other objects. Position the device a little more in the room's centre if required.
- Check the temperature setting at the device. Reduce the set temperature if it is higher than the room temperature.

The device is loud or vibrates:

- Check whether the device is set up in a stable and upright position.

Condensate is leaking from the basic device:

- Check the device for leaks.
- Check whether the condensation hose has been plugged in properly.

The compressor does not start:

- Check whether the overheating protection of the compressor has tripped. Disconnect the device from the mains and let it cool down for approx. 10 minutes before reconnecting it.
- The compressor may start up with a delay of 3 minutes, as it is provided with an internal protection against direct restart.

The device gets very warm, is loud or is losing power:

- Check the air inlet and air filter for dirt. Remove external dirt.
- From the outside, check the device for dirt (see chapter Maintenance). If the inside of the device is dirty, have it cleaned by a specialist company for cooling and air-conditioning or by the manufacturer.

The device still does not operate correctly after these checks:

- Please contact the customer service. If necessary, bring the device to a specialist company for cooling and air-conditioning or to the manufacturer for repair.

Maintenance

Maintenance intervals

Maintenance and care interval	before every start-up	as needed	at least every 2 weeks	at least every 4 weeks	at least every 6 months	at least annually
Check air inlet and outlet for dirt and foreign objects and clean if necessary	X					
Clean the exterior		X				X
Visually check the inside of the device for dirt		X		X		
Check the air filter for dirt and foreign objects and clean or replace if necessary	X		X			
Replace the air filter		X			X	
Check for damage	X					
Check the attachment screws		X			X	
Test run					X	
Checking the freedom of movement/functionality of the float switch			X		X	
Cleaning the condensation tray				X		
Cleaning the filter of the condensation tank				X		
Replacing the filter of the condensation tank		X				X
Cleaning the heat exchanger of the outdoor unit		X				X
Checking the refrigerant	X					



Maintenance and care log

Device type:

Device number:

Maintenance and care interval	1	2	3	4	5	6	7	8	9	10	11	12	13	14	15	16
Check air inlets and outlets for dirt and foreign objects and clean if necessary																
Check the air filter for dirt and foreign objects and clean or replace if necessary																
Clean the exterior																
Visually check the inside of the device for dirt																
Replace the air filter																
Check the attachment screws																
Test run																
Checking the freedom of movement/functionality of the float switch																
Cleaning condensation tray																
Cleaning the filter of the condensation tank																
Replacing the filter of the condensation tank																
Cleaning the heat exchanger of the outdoor unit																
Checking the coolant																

1. Date: Signature:	2. Date: Signature:	3. Date: Signature:	4. Date: Signature:
5. Date: Signature:	6. Date: Signature:	7. Date: Signature:	8. Date: Signature:
9. Date: Signature:	10. Date: Signature:	11. Date: Signature:	12. Date: Signature:
13. Date: Signature:	14. Date: Signature:	15. Date: Signature:	16. Date: Signature:

Safety instructions for maintenance



Wear safety glasses

For start-up, maintenance and troubleshooting always wear suitable safety glasses.



Wear a protective mask

For cleaning and maintenance tasks wear an appropriate protective mask.



Wear protective gloves

For start-up, maintenance and troubleshooting always wear suitable protective gloves.



⚠ Danger

Refrigerant R454C!

H221 – Flammable gas.

H280 – Contains gas under pressure; may explode if heated.

P210 – Keep away from heat, sparks, open flames and other ignition sources. No smoking.

P377 – Leaking gas fire; Do not extinguish, unless leak can be stopped safely.

P381 – Eliminate all ignition sources if safe to do so.

P410 and P403 – Protect from sunlight. Store in a well-ventilated place.



⚠ Warning of electrical voltage

Do not touch the mains plug with wet or damp hands.

- Switch the device off.
- Disconnect the device from the mains by removing the mains plug from the socket. When doing so, be sure to hold the plug, not the cable.



⚠ Warning of electrical voltage

Tasks which require the device to be opened must only be carried out by authorised specialist companies or by the manufacturer.

Non-professionals are not authorised to carry out maintenance and repair tasks!

- The entire refrigerant circuit is a maintenance-free, hermetically sealed system and may only be maintained or repaired by specialist companies for cooling and air-conditioning or by the manufacturer.



⚠ Caution

Risk of cuts due to sharp corners and edges

Sharp edges and corners in the device interior may cause cuts when maintenance tasks are carried out.

- Wear protective gloves.



Notice

Do not tilt the device, since this may damage the device.

Safety signs and labels on the device

Check the safety signs and labels attached to the device at regular intervals. Replace illegible safety signs!

Cleaning the housing

Clean the housing with a soft, damp and lint-free cloth. Make sure that no moisture enters the housing. Protect electrical components from moisture. Do not use any aggressive cleaning agents such as cleaning sprays, solvents, alcohol-based or abrasive cleaners to dampen the cloth.

Visual inspection of the inside of the device for dirt

1. Remove the air filter.
2. Use a torch to illuminate the openings of the device.
3. Check the inside of the device for dirt.
4. If you see a thick layer of dust, have the inside of the device cleaned by a specialist company for cooling and air-conditioning or by the manufacturer.
5. Put the air filter back in.

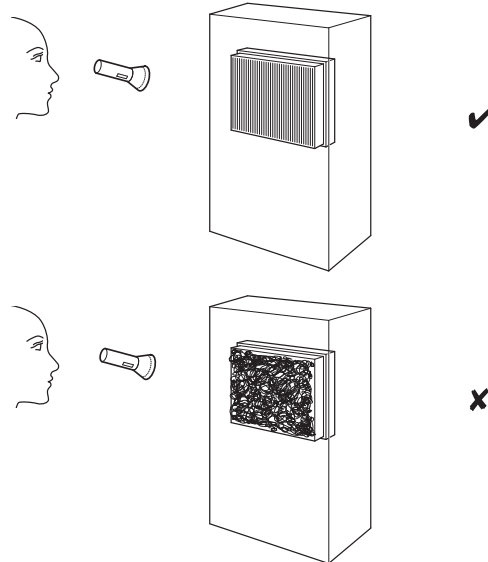

Cleaning the air filter

Notice

Make sure that the air filter is not worn or damaged. The corners and edges of the air filter must not be deformed or rounded. Before reinserting the air filter, make sure that it is undamaged and dry!



Warning

Risk of infection due to contamination in the device

Contamination in the device's condensation area can for instance cause infections by humidity or legionella.

- Wear a respiratory mask when you open the device and carry out work on the device interior.

1. Press the two locking latches (18) downwards and hinge down the air inlet plate towards the front.
⇒ The air inlet plate is held in position by two rebound straps.
2. Remove the air filter (19) from the air inlet plate by lifting the air filter out.

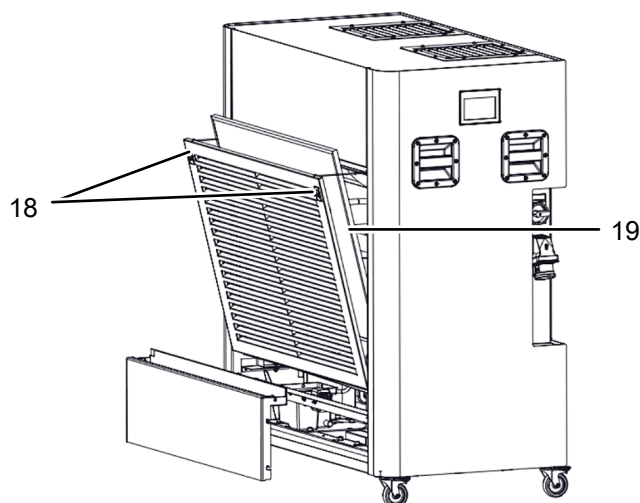

3. Dispose of the air filter (19) according to the national regulations.
4. Insert a new air filter into the filter insert.
5. Push the air inlet plate up again.
⇒ The locking latches (18) engage automatically and lock the air inlet plate.

Cleaning the heat exchanger of the outdoor unit

Warning

Risk of injury due to rotating parts

Rotating fans may cause injuries.

- Keep your hands away from the fans.

Proceed as follows to clean the heat exchanger:

1. Open up the cover (23).
2. Remove the cover plate (24).
3. Disassemble the fan plates (25).
4. Loosen the two screws at the upper rear panel (26) and lift out the upper rear panel.
5. Draw the lower rear panel (27) towards you and lift it out.
6. Clean the components with a damp cloth.
7. Mount the rear panels, fan plates and cover plate again, carrying out the steps from the disassembly process in reverse order.

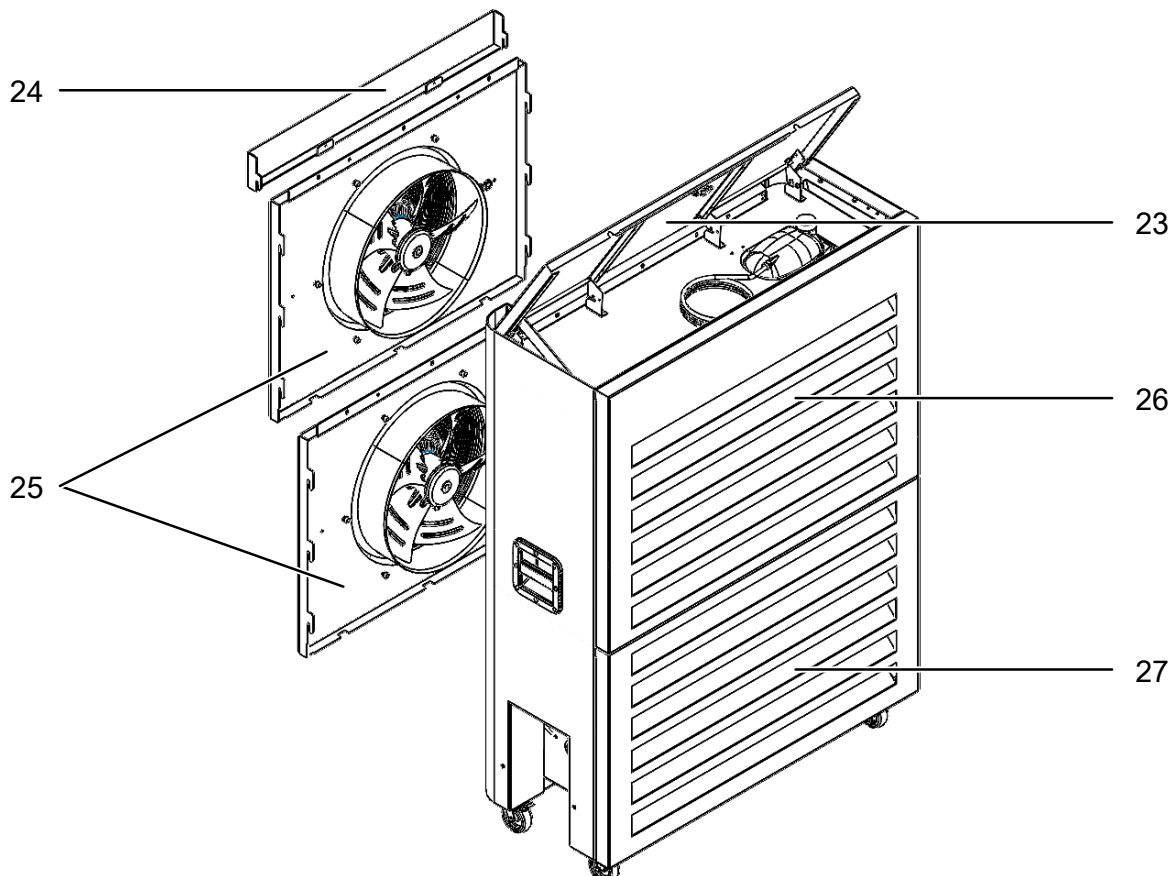

Checking and topping up the water / glycol mixture



Danger

Risk of injury from contact with glycol!

Contact with the escaping water / glycol mixture can cause severe eye irritation and internal injuries when swallowed (e.g. kidney damage).

Avoid contact with the water / glycol mixture.

Never drink the water / glycol mixture!

Always wear safety glasses, protective gloves and tight-fitting work clothing.

In case of contact with eyes: Rinse carefully with water for some minutes. Remove contact lenses, if applicable. Continue rinsing.

Remove any escaping liquid.

Observe the relevant safety data sheets.



Warning

Risk of injury due to hot liquid and vapour

When the liquid is heated or evaporates, hot liquid may leak and vapour may emit, which may cause severe injuries.

- Never remove the lid of the tank while the device is switched on or the liquid in the tank is heated.
- When filling the tank, always wear a protective mask, protective gloves and eye protection.

Notice

The water / glycol circuit is filled with a fluid consisting of 35 % Long Life IAT (Inorganic Acid Technology) ethylene glycol (ethanediol 3,5,5-trimethylhexanoate) and 65 % water. The mixing ratio of 35 % ethanediol 3,5,5-trimethylhexanoate to 65 % water must not be changed when adding additional liquid!

Proceed as follows to fill the water / glycol circuit with liquid:

- ✓ The device is switched off and the plug is disconnected from the mains socket.
 - ✓ The contained water / glycol mixture has cooled down.
1. Check whether the outdoor unit is lower or at most the same height as the basic device. If this is the case, continue with step 3.
 2. Disconnect the outdoor unit from the basic device, place both units on one level and connect them with the hose set (see chapter "Assembly and start-up").
 3. Remove the screw cap from the tank (9).
 4. Check the glycol content with an antifreeze tester according to the technical data. The mixing ratio must be 35 % Long Life IAT (Inorganic Acid Technology) ethylene glycol (ethanediol 3,5,5-trimethylhexanoate) and 65 % water.
 5. Top up the water / glycol mixture with the correct mixing ratio until the filling level is 40 mm below the top edge of the tank.
 6. Place the screw cap back on the tank (9) and tighten it.
 7. Plug the mains plug into the mains socket. Switch on the basic device and activate the cooling mode. Set a setpoint that is lower than the current room temperature (see Operation chapter).

8. The device is fitted with an automatic venting system that collects any remaining air inside the system and channels it into the tank. A gurgling sound is caused during this process. Allow the device to run until you can no longer hear any gurgling sounds.
9. Switch the basic device off and remove the mains plug from the mains socket.
10. Check the liquid level in the tank.
 - ⇒ If the filling level is a maximum of 40 mm below the top edge of the tank, the system is filled correctly, otherwise repeat the steps from step 3 onwards.
11. If the basic device or outdoor unit have been moved for filling, disconnect the units and return them to their original installation location. Reconnect the units with the hose set (see chapter "Assembly and start-up").

Activities required after maintenance

If you want to continue using the device:

- If the basic device has been transported, allow it to stand for 30 minutes before using it again so that the lubricating oil can be returned to the compressor. Acting contrary might lead to compressor damage and a malfunctioning basic device.
- Reconnect the device to the mains.

If you do not intend to use the device for a considerable time:

- Store the device according to the Transport and storage chapter.

Technical annex

Technical data

Model	AC 15000
Article number AC 15000 complete unit basic device outdoor unit hose set	
Cooling capacity (at 25 °C)	15 kW 51,240 BTU/h
Max. cooling capacity	18.3 kW 62,442 BTU/h
Operating range outdoor unit basic device	5 °C to 50 °C 5 °C to 50 °C
Max. air volume flow	3450 m ³ /h
Min. air volume flow	2000 m ³ /h
Fusing 	16 A
Power supply	400 V / 50 Hz
WLAN transmission frequency	2.4 GHz
Maximum transmission capacity	< 20 dBm
Type of protection outdoor unit basic device	IP 24 IP 22
Max. power input (cooling operation)	79.60 kW
Sound pressure level at a distance of 1 m(stage 6)	69 dB(A)
Heat transfer fluid in the second cooling circuit (with a hose set (10 m)) Glycol specification	25 l (65 % water / 35 % glycol) Long Life IAT (Inorganic Acid Technology) ethylene glycol
Refrigerant (basic device)	R454C
Amount of refrigerant	2400 g
GWP factor	148
CO ₂ equivalent	0.355 t
Suction side pressure	2.8 MPa
Discharge side pressure	2.8 MPa
Max. permissible pressure	2.8 MPa
Dimensions of the basic device (length x width x height)	1175 x 601 x 1315 mm
Dimensions of the outdoor unit (length x width x height)	1019 x 509 x 1420 mm
Minimum distance to walls and other objects (basic device):	A (top): 30 cm B (rear): 30 cm C (side): 30 cm D (front): 30 cm

Model	AC 15000
Minimum distance to walls and other objects (outdoor unit):	<p>A (top): 30 cm</p> <p>B (rear): 30 cm</p> <p>C (side): 30 cm</p> <p>D (front): 300 cm</p>
Weight basic device	200 kg
Weight outdoor unit	135 kg
Weight of hose set	26 kg
Weight per hose	13 kg

Circuit diagrams

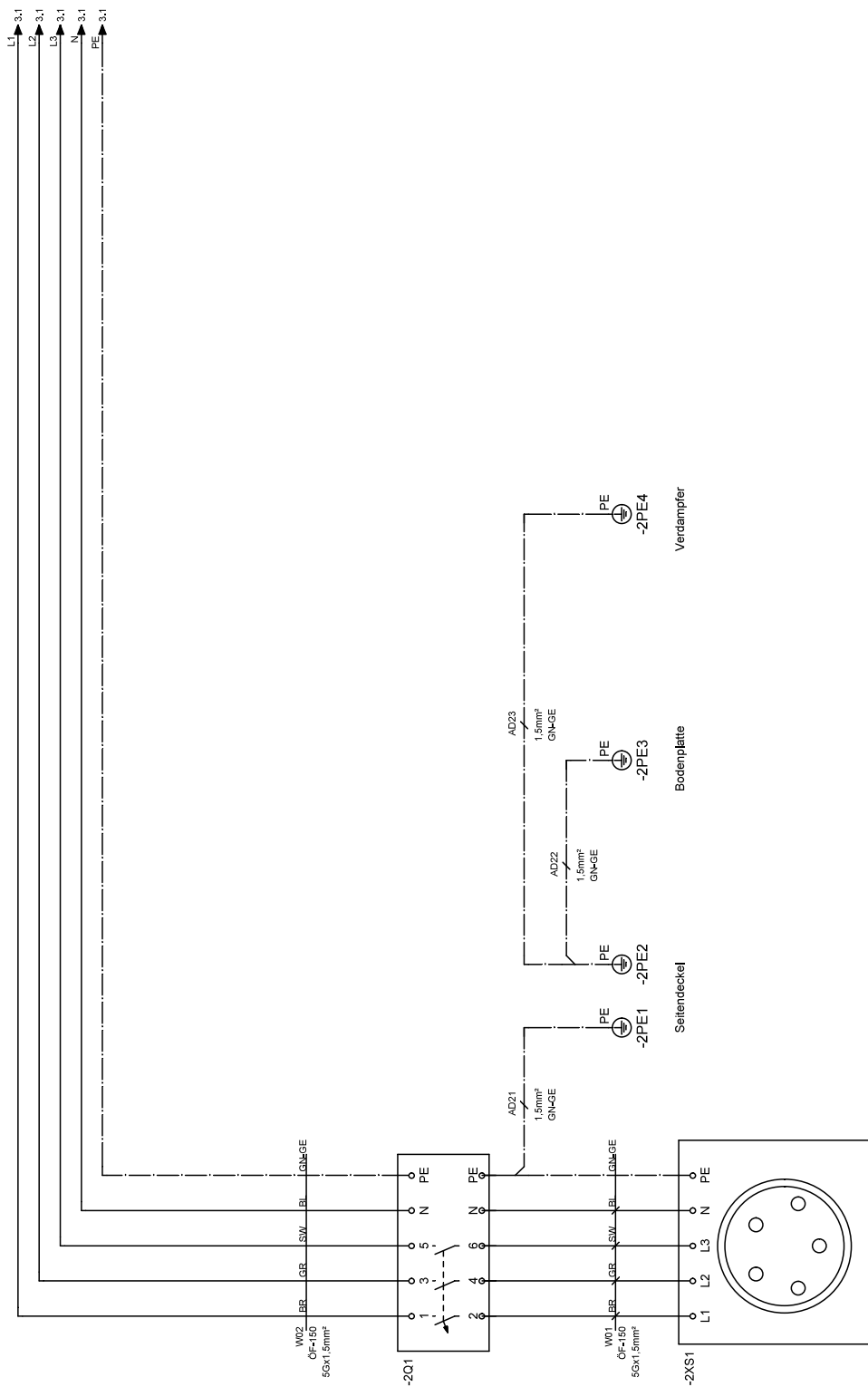

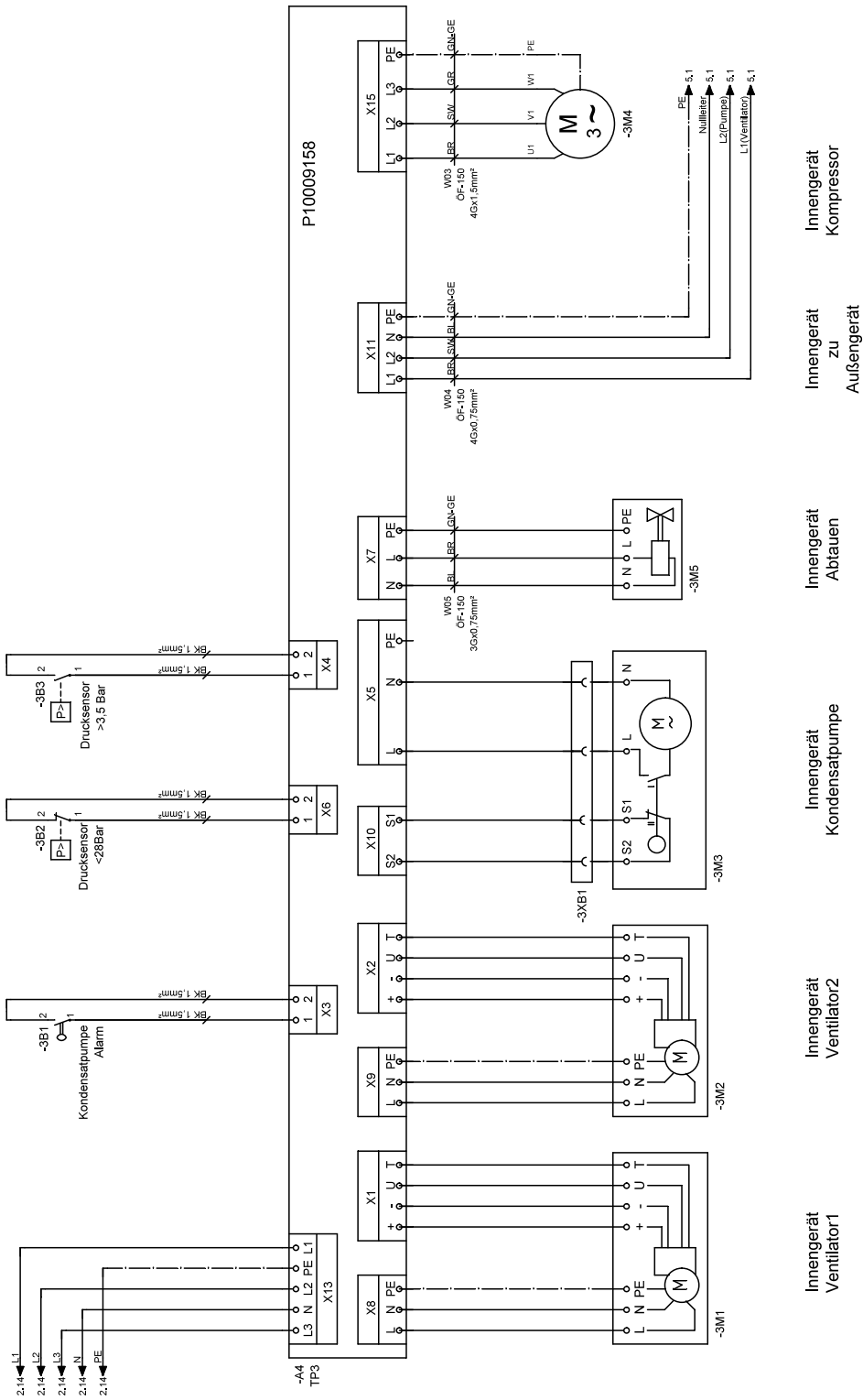

Innengerät zu Außengerät
Innengerät Kompressor

Innengerät Ablaufen

Innengerät Kondensatpumpe

Innengerät Ventilator2

Innengerät Ventilator1

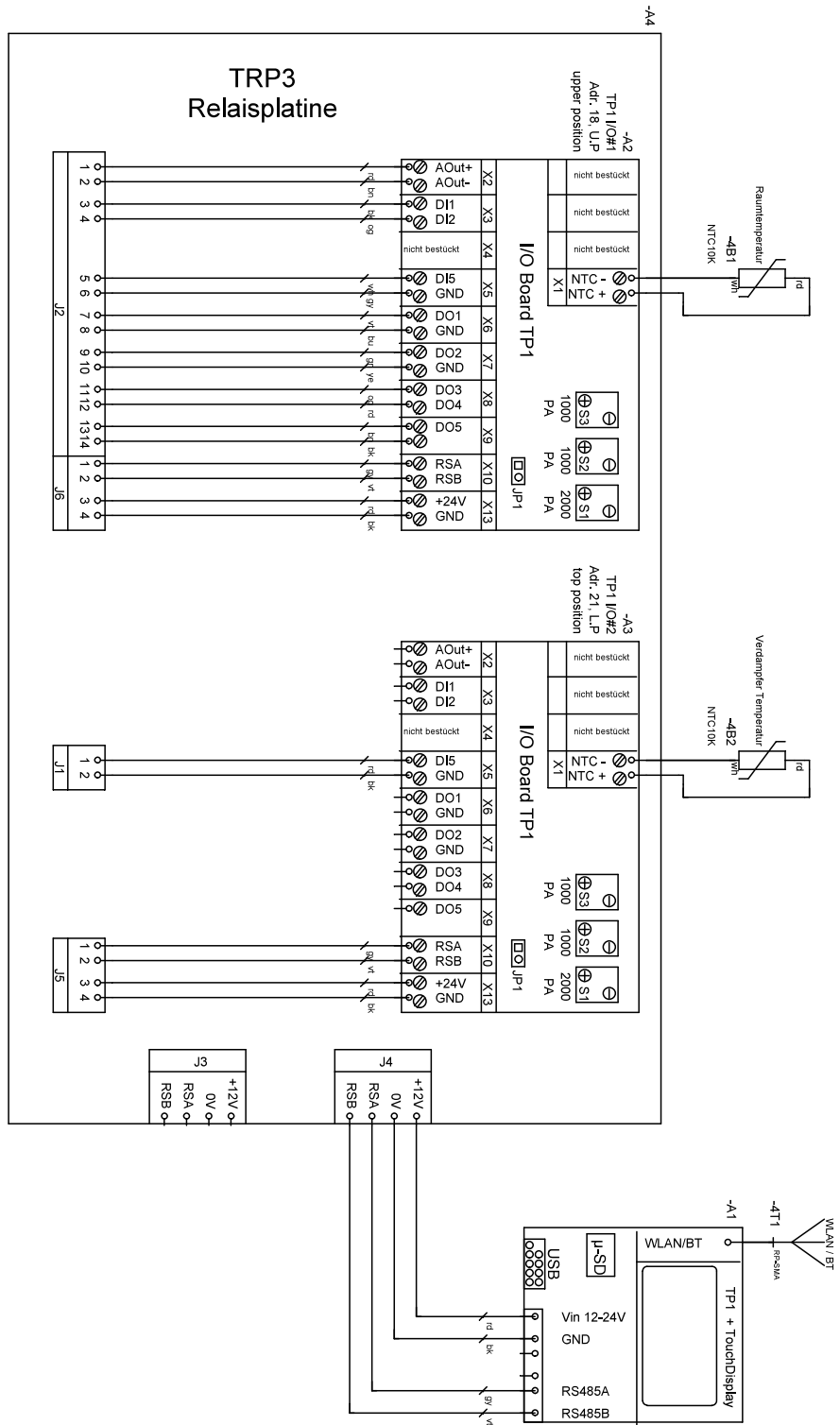

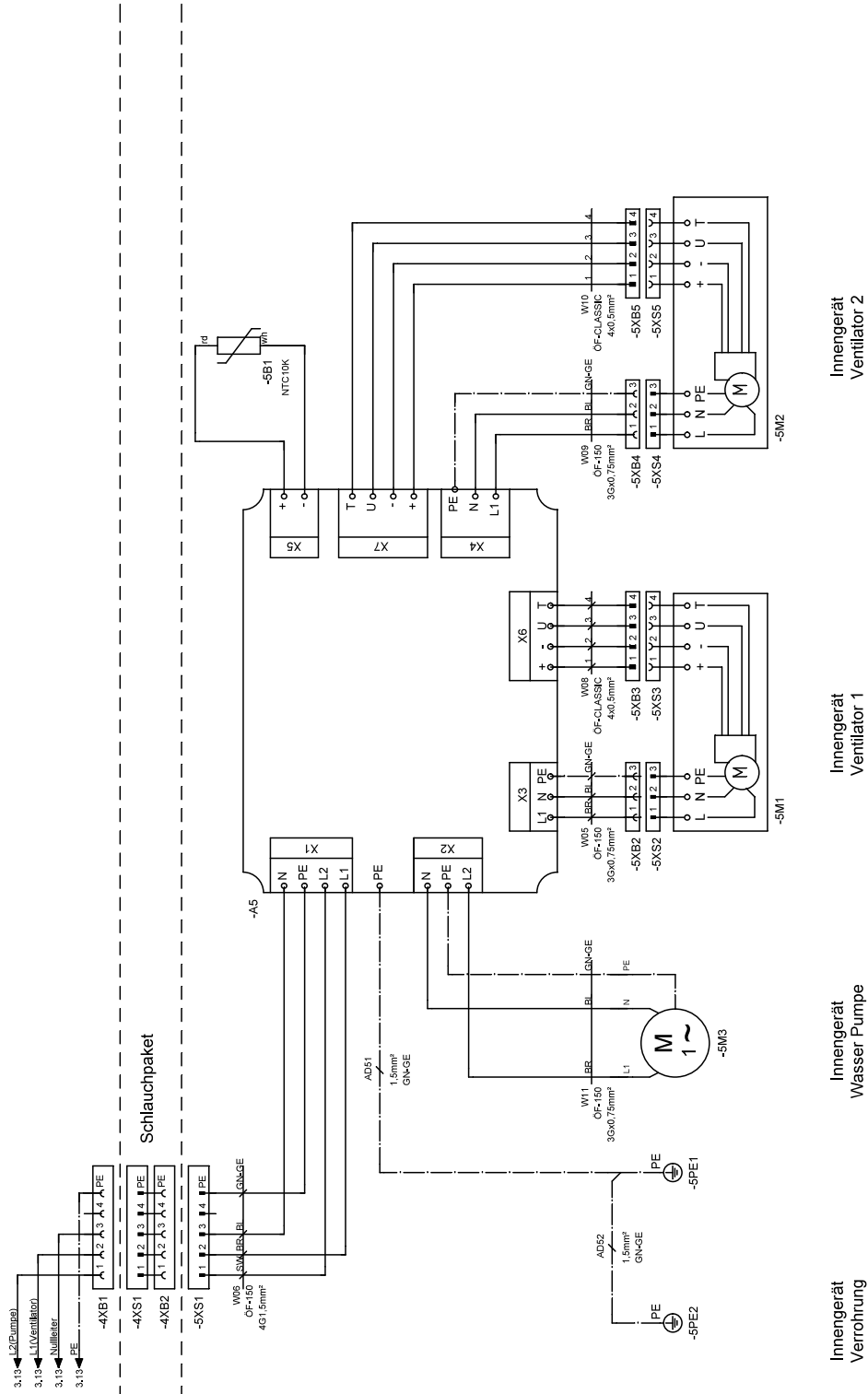

Flow diagram

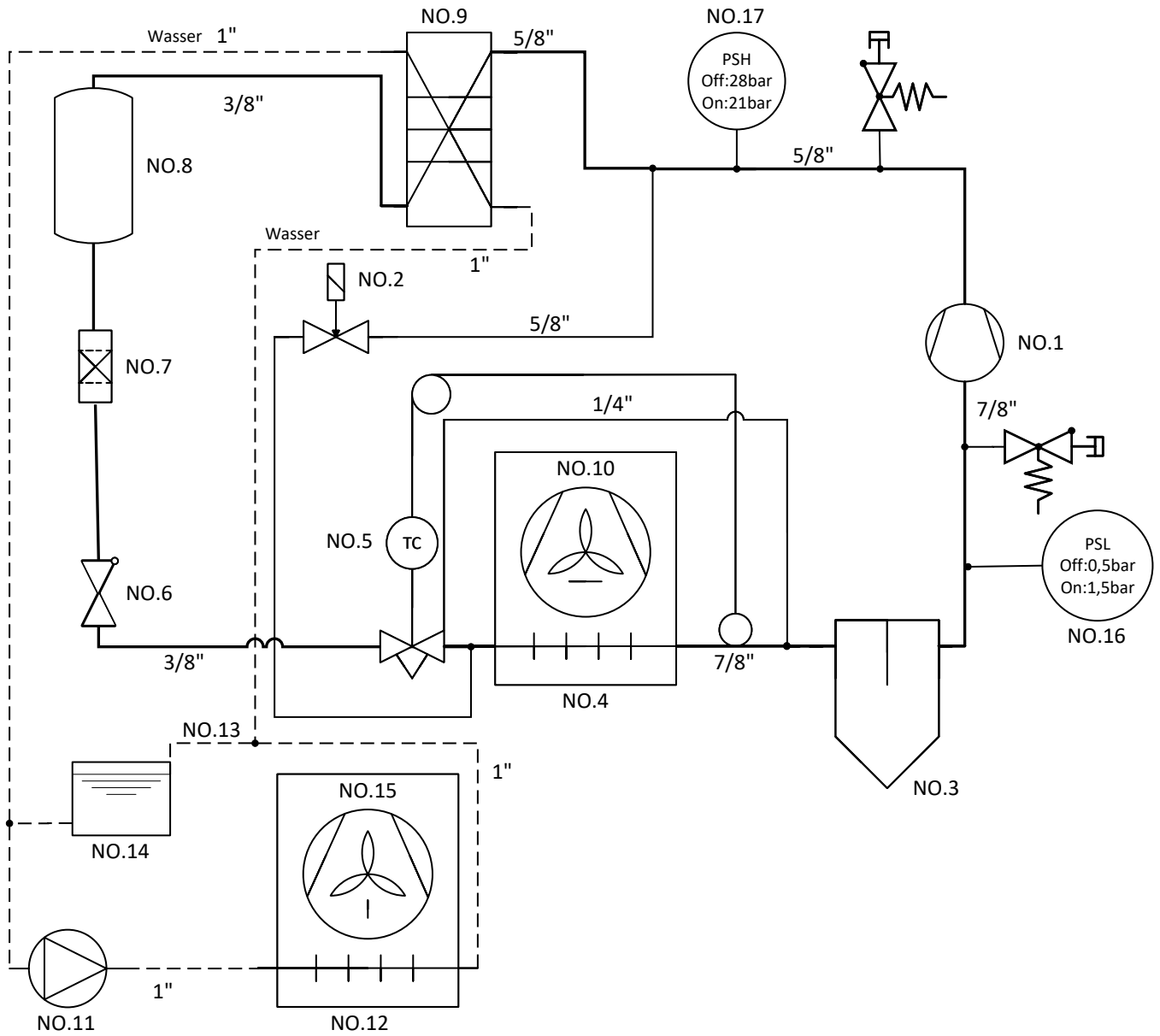

Overview and list of spare parts basic device

Note: The position numbers of the spare parts differ from those describing the positions of other parts mentioned in this operating manual.

en

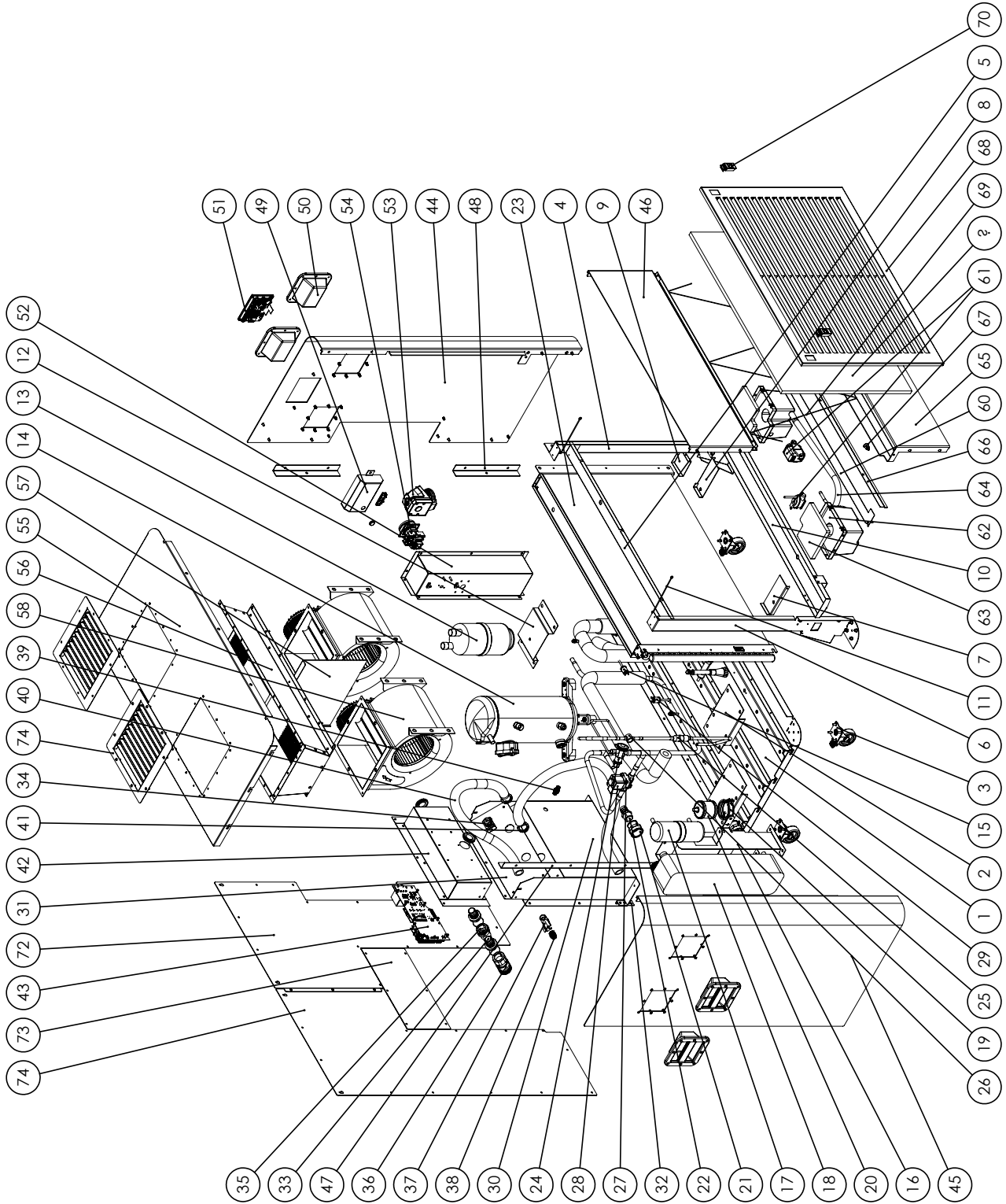

No.	Quantity	Designation	Article number
1	1	Bottom	P10009041
2	3	Support	P10009042
3	1	Wheel	P10001530
4	1	Heat exchanger holding fixture	P10009044
5	1	Heat exchanger holding fixture	P10009046
6	1	Heat exchanger holding fixture	P10009045
7	1	Corner piece, left-hand	P10009047
8	1	Corner piece, right-hand	P10009048
9	1	Condensation tray	P10009049
10	1	Condensation tray	P10009181
11	2	Retaining strap	P10009066
12	1	Retainer	P10009043
13	1	Suction collector	P10009008
14	1	Compressor	P10009002
15	1	Pressure switch	P10008732
16	1	Holding fixture	P10009053
17	1	Receiver	P10009007
18	1	Heat exchanger	P10009011
19	1	Pipe clamp	P10009067
20	1	Filter drier	P10009005
21	2	Reducing socket	P10009151
22	2	Hose connector	P10009152
23	1	Evaporator AC 15000	P10009010
24	1	Expansion valve	P10009009
25	1	Check valve	P10009006
26	1	Inspection glass	P10009144
27	1	Magnet valve	P10009003
28	1	Solenoid coil	P10009004
29	1	Pressure switch	P10008731
30	1	Connection plate	P10009037
31	1	Amplification	P10009052
32	2	Amplification	P10009051
33	2	Hose connection	P10009539
34	1	Mount	P10009542
35	1	Quick coupling	P10009017
36	1	Quick coupling	P10009016
37	1	Coupling housing	P10009543
38	1	Insert	P10009467
39	1	Bulkhead connector	T10004014
40	1	Hose	P10009146
41	2	Nut	P10009101
42	1	Electrical box	P10009060
43	1	AC 15000	B1896
44	1	Outer wall, right-hand	P10009036

No.	Quantity	Designation	Article number
45	1	Outer wall, left-hand	P10009035
46	1	Middle section	P10009033
47	1	Mounting bracket	P10009031
48	2	Mounting bracket	P10009030
49	1	Cover	P10009061
50	4	Handle	P10008843
51	1	Control unit TP1 AC	B1688
52	1	Terminal box	P10009029
53	1	Plug	P10008166
54	1	Main switch	P10001553
55	1	Cover	P10009059
56	1	Distribution box	P10009423
57	1	Guide plate	P10009424
58	2	Fan	P10009415
59	1	Condensate angle	P10009376
60	1	Condensate pump	P10009145
61	2	Condensation tray	P10008756
62	2	Filter	P10009131
63	1	Hose	P10006829
64	1	Inspection flap	P10009032
65	1	Clamping lug	P10009034
66	2	Lock pin	P10009063
67	1	Air grille	P10009050
68	1	Filter retainer	P10009476
69	2	Latch	P10002011
70	1	Air filter	P10009130
71	1	Cover, left-hand	P10009038
72	1	Cover of electrical box	P10009040
73	1	Cover, right-hand	P10009039
74	2	Air outlet	B1816

Overview and list of spare parts outdoor unit

Note: The position numbers of the spare parts differ from those describing the positions of other parts mentioned in this operating manual.

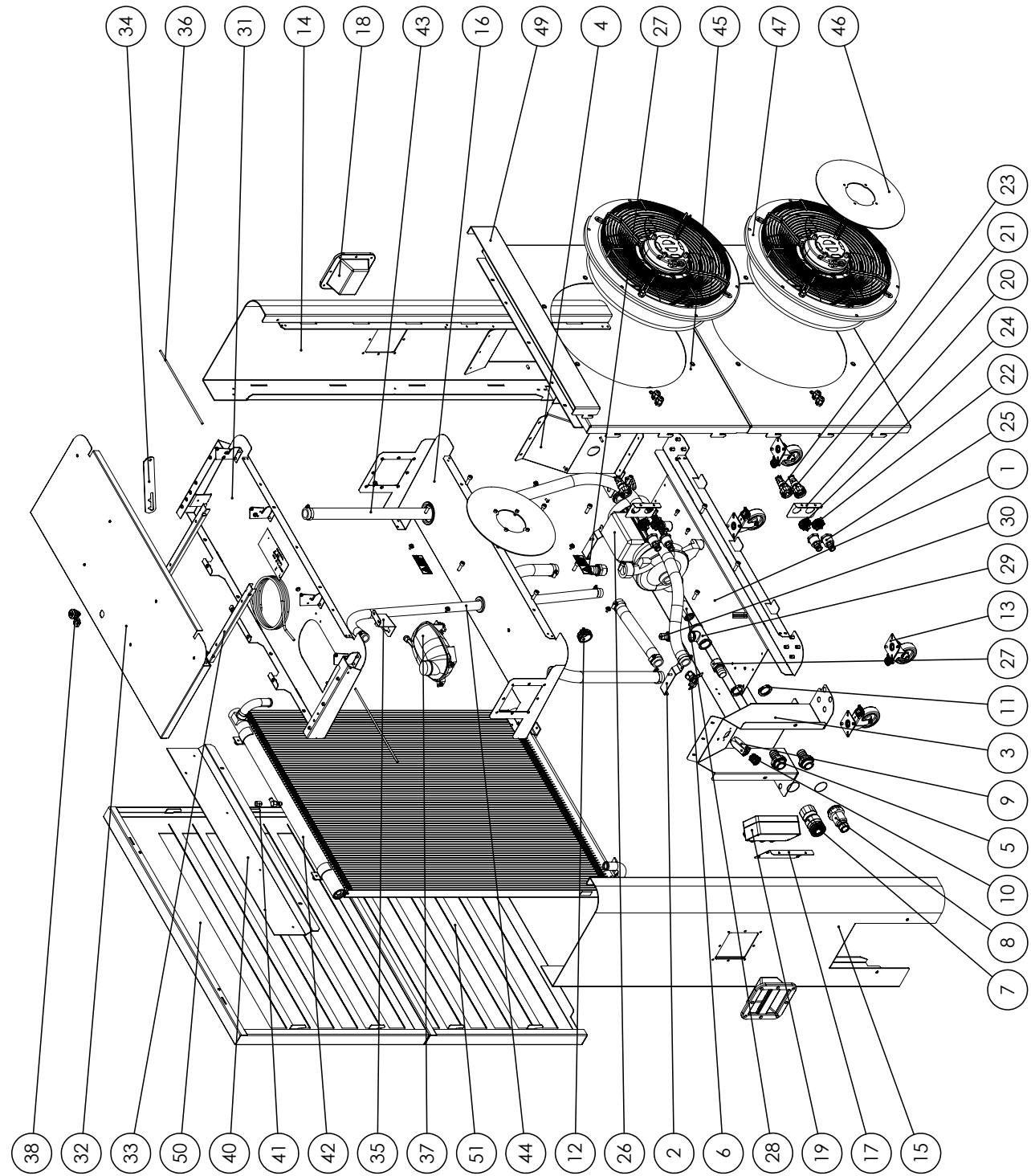

No.	Quantity	Designation	Article number
1	1	Bottom	P10009089
2	2	Heat exchanger holding fixture	P10009091
3	1	Connection plate	P10009080
4	1	Mounting bracket	P10009081
5	2	Hose connection	P10009539
6	1	Mount	P10009542
7	1	Quick coupling	P10009016
8	1	Quick coupling	T10009017
9	1	Nozzle housing	P10009065
10	1	Insert	P10009544
11	2	Nut	P10009101
12	2	Pipe clamp	P10009154
13	1	Wheel	P10001530
14	1	Side frame, right-hand	P10009077
15	1	Side frame, left-hand	P10009078
16	1	Intermediate plate	P10009083
17	1	Electrical sheet	P10009545
18	2	Handle	P10008843
19	1	Electrical components outside	B1795
20	2	Holding fixture	P10009109
21	2	Circular connector	P10009402
22	2	Circular connector	P10009401
23	2	Circular connector	P10000510
24	2	Built-in socket	P10000512
25	4	Screw cap	P10008788
26	1	Pump	P10009022
27	2	Hose connector	P10009102
28	1	Long nipple	P10009106
29	1	T-piece	P10009484
30	1	Hose connector	P10009485
31	1	Intermediate plate	P10009087
32	1	Cover	P10009082
33	2	Locking mechanism	P10009564
34	1	Rail grid	P10009563
35	1	Tank holding fixture	P10009093
36	2	Axis roof	P10009486
37	1	Compensation tank	P10009148
38	1	Lock	P10008826
39	1	Cover plate rear	P10009085
40	1	Reduction IGIGM12M5	P10009549
41	1	Heat exchanger	P10009020
42	1	Hose	P10009146
43	1	Hose	P10009487
44	2	Fan holder	P10009076



No.	Quantity	Designation	Article number
45	1	Fan protection cover	P10009094
46	1	Fan protection cover II	Alternative to P10009094
47	2	Fan	P10009013
48	1	Front panel	P10009079
49	1	Rear panel top	P10009489
50	1	Rear panel bottom	P10009490

Overview and list of spare parts display unit

Note: The position numbers of the spare parts differ from those describing the positions of other parts mentioned in this operating manual.

Note: The buffer battery may only be replaced by a qualified electrician. Contact the relevant personnel or the manufacturer in this case.

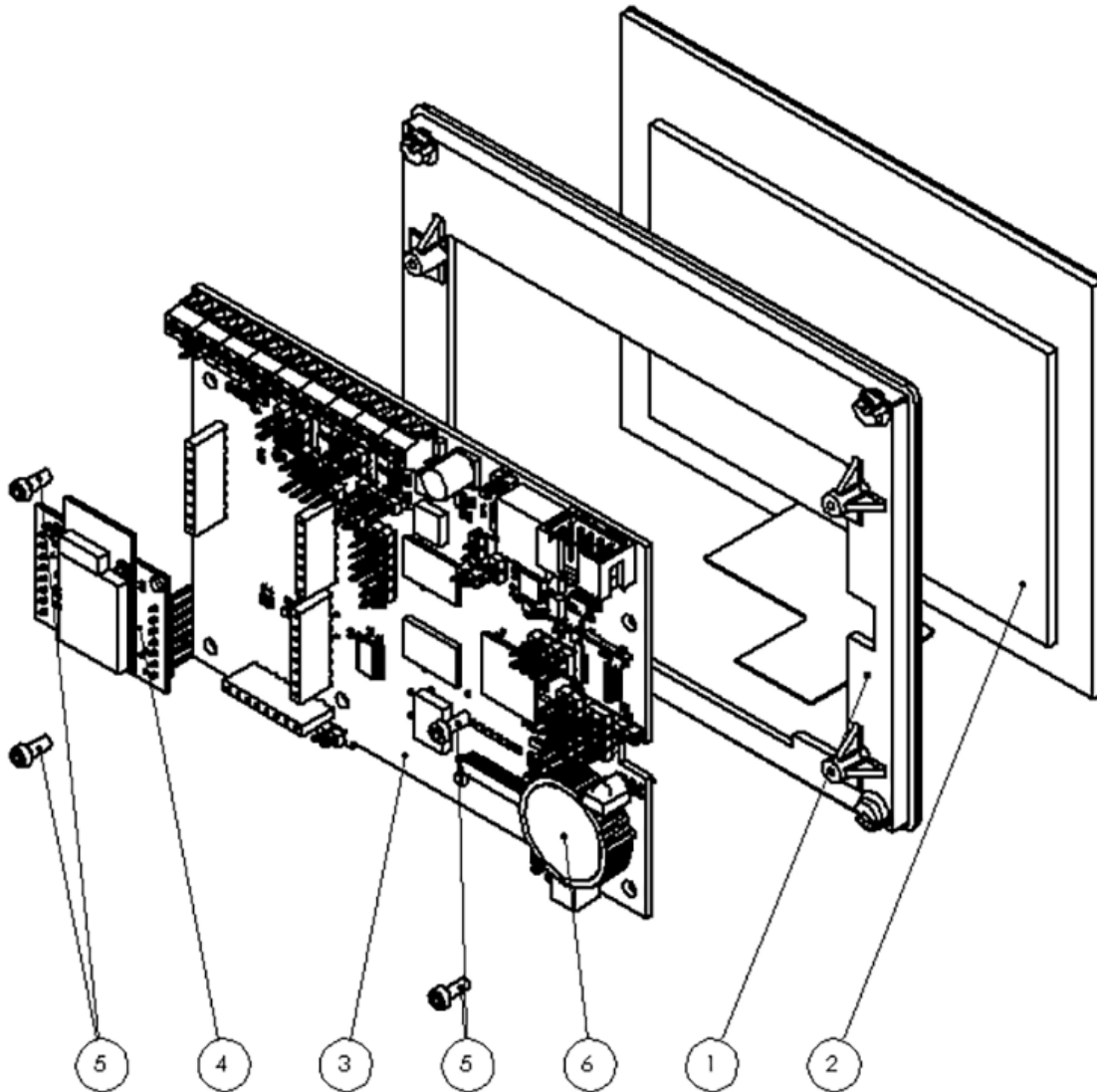

No.	Quantity	Designation	Article number
1	1	Display frame, embedded (T0007716)	P10008757
2	1	Display (TFT DVT-043T-JT-R9T-P7)	P10007764
3	1	Printed circuit board (e-mainboard)	P10002358
4	1	Printed circuit board (radio module PCB ESP32-Mod)	P10007825
5	4	Screw (Liko Torx Plasfast 2.5x6 galvanised)	P10007290
6	1	Battery (CR2032)	-

Disposal

Always dispose of packing materials in an environmentally friendly manner and in accordance with the applicable local disposal regulations.



The icon with the crossed-out wheeled bin indicates that this device and any associated components must not be disposed of with household waste at the end of their life, in accordance with the Waste Electrical and Electronic Equipment Directive (2012/19/EU) and national laws.

You will find collection points for free return of waste electrical and electronic equipment in your vicinity. The addresses can be obtained from your municipality or local administration. Otherwise, please contact an official recycling centre for electronic and electrical equipment authorised for your country.

The separate collection of waste electrical and electronic equipment aims to enable the re-use, recycling and other forms of recovery of waste equipment as well as to prevent negative effects for the environment and human health caused by the disposal of hazardous substances potentially contained in the equipment.

The device is operated with fluorinated greenhouse gas, which can be dangerous for the environment and contribute to global warming when emitted to the atmosphere.

Further information is provided on the nameplate.

Dispose of the refrigerant appropriately and according to the national regulations.

Dispose of the water / glycol mixture in the device properly according to the national regulations.

Only for United Kingdom

According to Waste Electrical and Electronic Equipment Regulations 2013 (SI 2013/3113) (as amended) devices that are no longer usable must be collected separately and disposed of in an environmentally friendly manner.

ORIGINAL EU Declaration of Conformity for a machine in accordance with 2006/42/EC, Annex II, Part 1, Section A		
1.	Machine:	Split-air-conditioning unit
2.	Manufacturer:	Trotec GmbH Grebbener Str. 7 52525 Heinsberg Germany online@trotec.com www.trotec.com
3.	./.	
4.	This declaration of conformity is issued under the sole responsibility of the manufacturer.	
5.	Object of the declaration:	Dantherm AC 15000 Year of manufacture as of: 2026
6.	The object of the declaration described in point 5 is in conformity with the following Union harmonisation legislation:	<ul style="list-style-type: none"> • 2006/42/EG • 2014/53/EU • 2011/65/EU • 2014/68/EU
7.	Applied harmonised standards:	<ul style="list-style-type: none"> • EN ISO 12100:2010 (OJ C 110 - 08/04/2011) • EN IEC 63000:2018 (OJ L 155 - 18/05/2020) • EN ISO 13857:2019 (OJ L 72 - 03/03/2021) • EN 60335-1:2012 (OJ L 115 - 13/04/2022) EN 60335-1:2012/AC:2014 EN 60335-1:2012/A11:2014 EN 60335-1:2012/A13:2017 EN 60335-1:2012/A15:2021
		<ul style="list-style-type: none"> • EN 60335-2-40:2003 (OJ C 348 - 28/11/2013) EN 60335-2-40:2003/A11:2004 EN 60335-2-40:2003/A12:2005 EN 60335-2-40:2003/A1:2006 EN 60335-2-40:2003/A13:2012/AC:2013 EN 60335-2-40:2003/A13:2012 EN 60335-2-40:2003/A2:2009 EN 60335-2-40:2003/AC:2006 EN 60335-2-40:2003/AC:2010 • EN 300 328 V2.2.2 (OJ L 34 - 06/02/2020)
	Common specifications applied: ./.	
	Other applied standards and specifications: ./.	
8.	./.	
9.	The machine is subject to the conformity assessment procedure on the basis of an internal production control.	
10.	Other information:	Authorised representative compiling the technical documentation: Trotec GmbH Grebbener Str. 7 52525 Heinsberg Germany

Heinsberg, 21 January 2026



Joachim Ludwig (Managing Director)

Dantherm Group

Grebener Straße 7
52525 Heinsberg
Germany
☎ +49 2452 962-0
online@trotec.com
www.trotec.com

Dantherm can accept no responsibility for possible errors and changes (en)
Der tages forbehold for trykfejl og ændringer (da)
Irrtümer und Änderungen vorbehalten (de)
Dantherm n'assume aucune responsabilité pour erreurs et modifications éventuelles (fr)

