

TTK 100 S

EN

OPERATING MANUAL
DEHUMIDIFIER



TROTEC

Table of contents

Notes regarding the operating manual..... 2

Safety 2

Information about the device..... 4

Transport and storage..... 5

Assembly and installation..... 6

Operation 7

Errors and faults..... 10

Maintenance 11

Technical annex..... 15

Disposal 15

Notes regarding the operating manual

Symbols



Warning of electrical voltage

This symbol indicates dangers to the life and health of persons due to electrical voltage.



Warning

This signal word indicates a hazard with an average risk level which, if not avoided, can result in serious injury or death.



Caution

This signal word indicates a hazard with a low risk level which, if not avoided, can result in minor or moderate injury.

Note

This signal word indicates important information (e.g. material damage), but does not indicate hazards.



Info

Information marked with this symbol helps you to carry out your tasks quickly and safely.



Follow the manual

Information marked with this symbol indicates that the operating manual must be observed.

You can download the current version of the operating manual and the EU declaration of conformity via the following link:

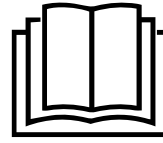

TTK 100 S



<https://hub.trotec.com/?id=41396>

Safety

Read this manual carefully before starting or using the device. Always store the manual in the immediate vicinity of the device or its site of use!



Warning

Read all safety warnings and all instructions.

Failure to follow the warnings and instructions may result in electric shock, fire and / or serious injury.

Save all warnings and instructions for future reference.

This appliance can be used by children aged from 8 years and above and persons with reduced physical, sensory or mental capabilities or lack of experience and knowledge if they have been given supervision or instruction concerning use of the appliance in a safe way and understand the hazards involved.

Children shall not play with the appliance. Cleaning and user maintenance shall not be made by children without supervision.

- Do not use the device in potentially explosive rooms.
- Do not use the device in aggressive atmosphere.
- Set the device up in an upright and stable position.
- Let the device dry out after a wet clean. Do not operate it when wet.
- Do not use the device with wet or damp hands.
- Do not expose the device to directly squirting water.
- Never insert any objects or limbs into the device.
- Do not cover or transport the device during operation.
- Do not sit on the device.
- This appliance is not a toy! Keep away from children and animals. Do not leave the device unattended during operation.
- Check accessories and connection parts for possible damage prior to every use of the device. Do not use any defective devices or device parts.

- Ensure that all electric cables outside of the device are protected from damage (e.g. caused by animals). Never use the device if electric cables or the power connection are damaged!
- The electrical connection must correspond to the specifications in chapter Technical data.
- Insert the mains plug into a properly secured mains socket.
- Observe the device's power input, cable length and intended use when selecting extensions to the power cable. Completely unroll extension cables. Avoid electrical overload.
- Before carrying out maintenance, care or repair work on the device, remove the mains plug from the mains socket. Hold onto the mains plug while doing so.
- Switch the device off and disconnect the power cable from the mains socket when the device is not in use.
- Do not under any circumstances use the device if you detect damages on the mains plug or power cable. If the supply cord is damaged, it must be replaced by the manufacturer, its service agent or similarly qualified persons in order to avoid a hazard.
Defective power cables pose a serious health risk!
- When positioning the device, observe the minimum distances from walls and other objects as well as the storage and operating conditions specified in the Technical data chapter.
- Make sure that the air inlet and outlet are not obstructed.
- Make sure that the suction side is kept free of dirt and loose objects.
- Do not remove any safety signs, stickers or labels from the device. Keep all safety signs, stickers and labels in legible condition.
- Only transport the device in an upright position with an emptied condensation tank or drain hose.
- Discharge the collected condensate before transport and storage. Do not drink it. Health hazard!

Intended use

Only use the device for drying and dehumidifying room air, while adhering to and following the technical data.

Intended use comprises:

- dehumidifying and drying:
 - living rooms, bedrooms, bathrooms and basements
 - laundries, holiday homes, camper vans, boats
- maintaining the dryness of:
 - storage spaces, archives, laboratories, garages
 - bathrooms, wash rooms, changing rooms etc.

Improper use

The device is not intended for industrial use.

- Do not place the device on wet or flooded ground.
- Do not place any objects, e.g. clothing, on the device.
- Do not use the device outdoors.
- Any unauthorised modifications, alterations or structural changes to the device are forbidden.
- Any operation other than as described in this manual is prohibited. Non-observance renders all claims for liability and guarantee null and void.

Personnel qualifications

People who use this device must:

- be aware of the dangers that occur when working with electric devices in damp areas.
- have read and understood the operating manual, especially the Safety chapter.

Maintenance tasks which require the housing to be opened must only be carried out by specialist companies for cooling and air-conditioning or by Trotec.

Residual risks



Warning of electrical voltage

Work on the electrical components must only be carried out by an authorised specialist company!



Warning of electrical voltage

Before any work on the device, remove the mains plug from the mains socket!
Hold onto the mains plug while pulling the power cable out of the mains socket.



Warning

Dangers can occur at the device when it is used by untrained people in an unprofessional or improper way! Observe the personnel qualifications!



Warning

The device is not a toy and does not belong in the hands of children.



Warning

Risk of suffocation!
Do not leave the packaging lying around. Children may use it as a dangerous toy.

Note

Do not operate the device without an inserted air filter! Without the air filter, the inside of the device will be heavily contaminated. This could reduce the performance and result in damage to the device.

Behaviour in the event of an emergency

1. Switch off the device.
2. In an emergency, disconnect the device from the mains feed-in: Hold onto the mains plug while pulling the power cable out of the mains socket.
3. Do not reconnect a defective device to the mains.

Information about the device

Description of the device

The device uses the principle of condensation to automatically dehumidify rooms.

The fan sucks damp room air through the air inlet, the air filter, the evaporator and to the condenser located behind it. The air is cooled at the cold evaporator until it is below the dew point. Water vapour contained in the room air precipitates on the evaporator fins as condensation or rime. The dehumidified, cooled air is slightly warmed at the condenser and blown out again. The drier air thus conditioned mixes with the air in the room. The humidity in the room where the device is positioned is reduced as air constantly circulates through the device.

Depending on the air temperature and the relative humidity, the condensed water either drops continuously or only during the defrost phase through the integrated drain nozzle into the condensation tank below. It is fitted with a float to measure the filling level.

The device has a control panel for operating and controlling the functions.

Once the maximum filling level of the condensation tank is reached or in case the condensation tank is not installed correctly, the condensation tank indicator light (see chapter Operating elements) on the control panel is illuminated. The device switches off. The condensation tank indicator light only goes out again once the emptied condensation tank is reinserted.

Optionally, the condensed water can be drained by attaching a hose at the condensation connection.

The device can reduce the relative humidity of a room to approx. 30 %.

In addition, the device may also be used as a kind of clothes dryer to dry wet laundry in living or working spaces.

Because of the heat radiation generated during operation, the room temperature may rise slightly.

Device depiction

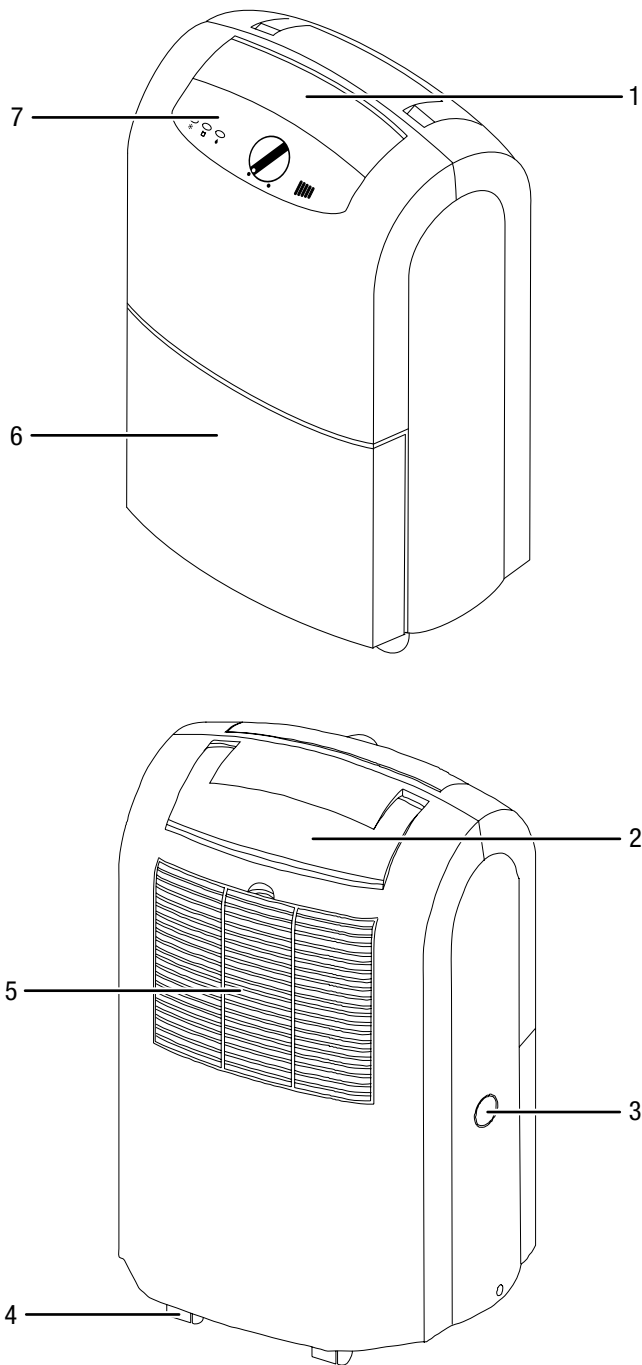

No.	Designation
1	Air outlet
2	Transport handle
3	Condensation drain hose connection
4	Wheels
5	Air inlet with air filter
6	Condensation tank
7	Control panel

Transport and storage

Note

If you store or transport the device improperly, the device may be damaged.

Note the information regarding transport and storage of the device.

Transport

To make the device easier to transport, it is fitted with wheels.

To make the device easier to transport, it is fitted with a carry handle.

Before transporting the device, observe the following:

- Switch off the device.
- Hold onto the mains plug while pulling the power cable out of the mains socket.
- Do not use the power cable to drag the device.
- Drain the remaining condensate from the device and the condensation drain hose (see chapter Maintenance).
- Only wheel the device on a level and smooth surface.

After transporting the device, observe the following:

- Set up the device in an upright position after transport.
- Leave the device to rest for 12 to 24 hours, so the refrigerant can accumulate within the compressor. Wait 12 to 24 hours before switching the device back on! Acting contrary might lead to compressor damage and a malfunctioning device. If so, any warranty claims will be voided.

Storage

Before storing the device, proceed as follows:

- Drain the remaining condensate from the device and the condensation drain hose (see chapter Maintenance).
- Hold onto the mains plug while pulling the power cable out of the mains socket.
- Drain any possibly remaining condensate.

When the device is not being used, observe the following storage conditions:

- dry and protected from frost and heat
- in an upright position where it is protected from dust and direct sunlight
- with a cover to protect it from invasive dust, if necessary
- Place no further devices or objects on top of the device to prevent it from being damaged.

Assembly and installation

Scope of delivery

- 1 x Device
- 1 x Air filter
- 1 x Manual

Unpacking the device

1. Open the cardboard box and take the device out.
2. Completely remove the packaging.
3. Fully unwind the power cable. Make sure that the power cable is not damaged and that you do not damage it during unwinding.

Start-up

When positioning the device, observe the minimum distance from walls or other objects as described in the Technical data chapter.

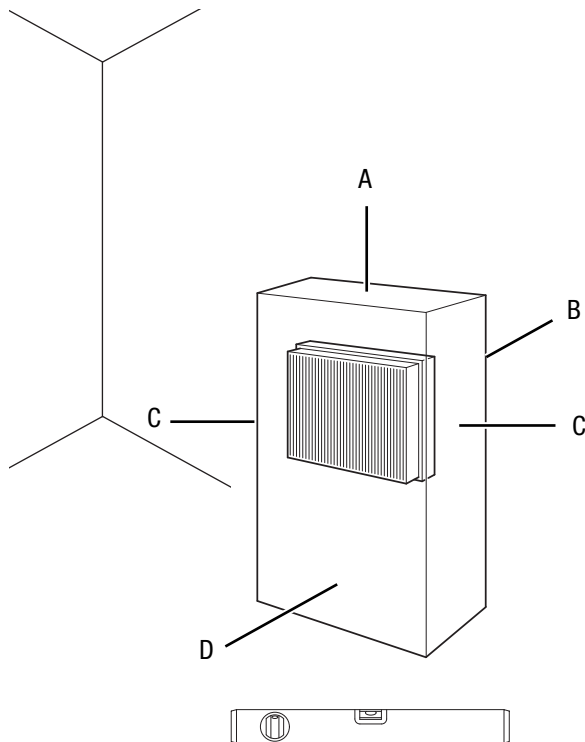

- Make sure that no curtains or other objects interfere with the air flow.
- When positioning the device, particularly in wet areas, secure it locally with an RCD (residual current device) which complies with the respective regulations.

Inserting the air filter

Note

Do not operate the device without an inserted air filter! Without the air filter, the inside of the device will be heavily contaminated. This could reduce the performance and result in damage to the device.

- Make sure that the air filter is installed before switching the device on.

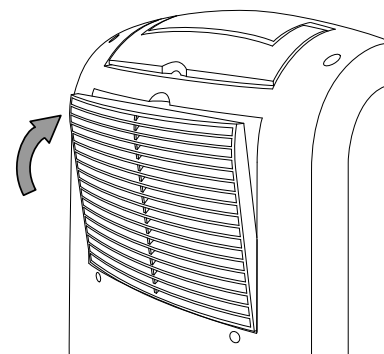
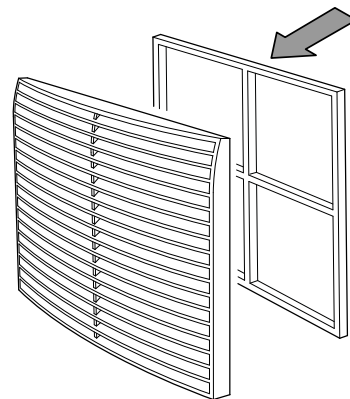
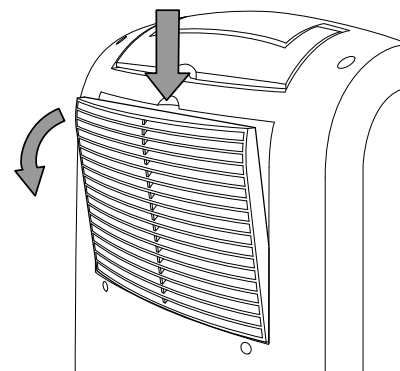

- Before restarting the device, check the condition of the power cable. If there are doubts as to the sound condition, contact the customer service.
- Set the device up in an upright and stable position.
- Do not create tripping hazards when laying the power cable or other electric cables, especially when positioning the device in the middle of the room. Use cable bridges.
- Make sure that extension cables are completely unrolled.
- When positioning the device, keep a sufficient distance to heat sources.

Opening the ventilation flaps

1. Prior to switching the device on, open the ventilation flaps at the air outlet.

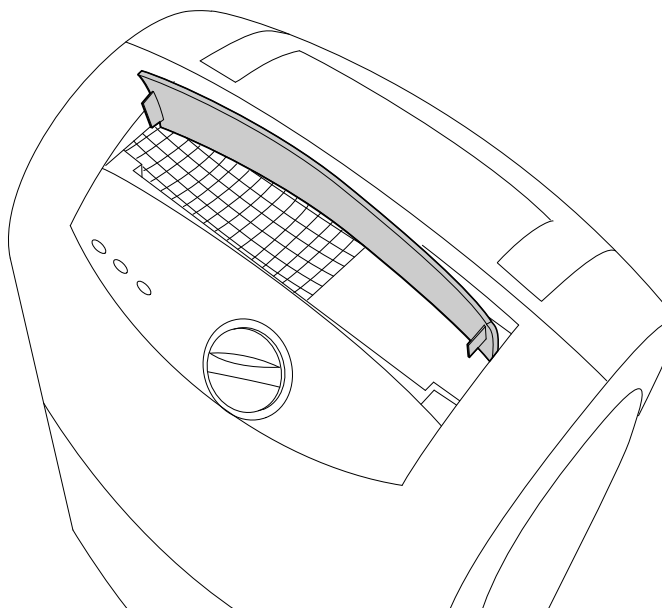
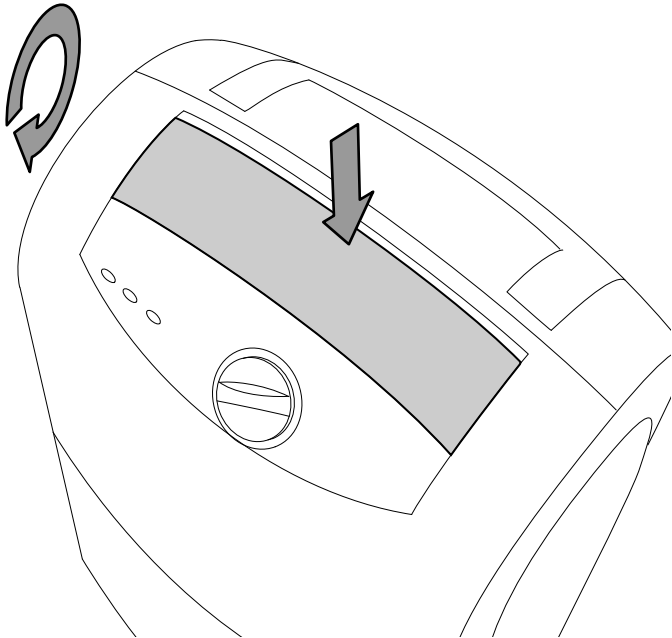

Operation

- Avoid open doors and windows.
- After being switched on, the device operates fully automatically.
- The fan permanently runs in dehumidification mode until the set nominal value is reached.

Operating elements

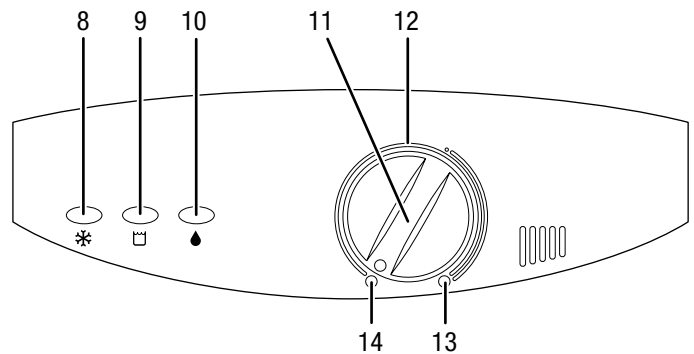

No.	Designation	Meaning
8	<i>Automatic defrost</i> LED	Illuminated in yellow when automatic defrosting is in progress.
9	<i>TANK FULL</i> LED	Illuminated in red when the condensation tank is full or not installed correctly.
10	<i>Operation</i> indicator LED	Illuminated in green when the device is switched on.
11	<i>On / off / target humidity level</i> rotary switch	For switching the device on or off For setting the relative humidity level (30 to 80 % RH)
12	12 o'clock position	Dehumidification mode (hygrostat-controlled)
13	Turned completely to the right	Continuous operation mode
14	Turned completely to the left	Device switched off

Inserting the condensation tank

- Ensure that the float inside the condensation tank is inserted correctly.
- Ensure that the condensation tank is empty and inserted correctly.

Connecting the power cable

- Insert the mains plug into a properly secured mains socket.

Switching the device on

Once you have completely installed the device as described in the Start-up chapter, you can switch it on.

1. When you use the device for the first time, turn the *on / off / target humidity level* rotary switch (11) clockwise to continuous operation all the way to the stop (13).
⇒ The *operation* indicator LED (10) is illuminated in green.
2. Let the device run in continuous operation mode for approx. one hour.
3. Adjust the humidity level by setting the *on / off / target humidity level* rotary switch (11) to a position between the stop positions on the left- (14) and right-hand side (13).
4. To maintain the current room humidity level, slowly turn the *on / off / target humidity level* rotary switch (11) to the left until the compressor switches off.

Setting the operating mode

Setting the desired relative room humidity

1. Adjust the humidity level by setting the *on / off / target humidity level* rotary switch (11) to a position between the stop positions on the left- (14) and right-hand side (13).
2. To maintain the current room humidity level, slowly turn the *on / off / target humidity level* rotary switch (11) to the left until the compressor switches off.

Dehumidification

The device keeps running until reaching the desired relative room humidity. Once the desired relative room humidity is exceeded, the compressor and ventilation switch back on.

Continuous operation

The device dehumidifies the air constantly and regardless of the current humidity level.

Operation with hose attached to the condensation connection

For continuous operation or unattended dehumidification, please connect a suitable condensation drain hose to the device.

- ✓ A suitable hose (diameter = 1/2 inch) is ready for use.
- ✓ The device is switched off.

1. Use a suitable tool (e.g. a slotted screwdriver) to remove the cover from the connection.

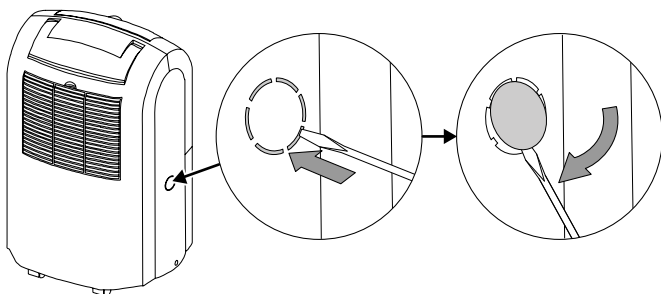

2. Remove the condensation tank.

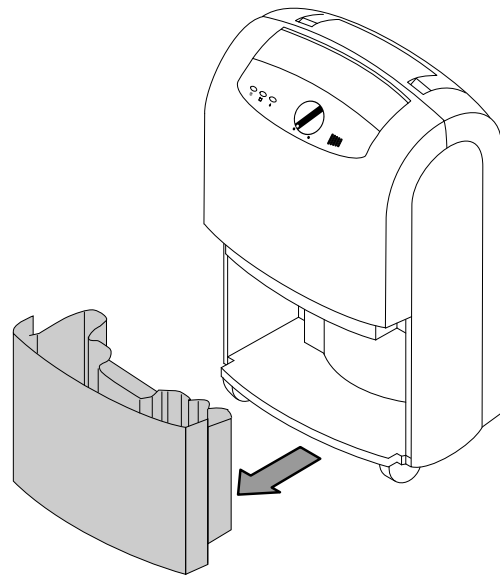

3. Push one end of the hose onto the hose connection.

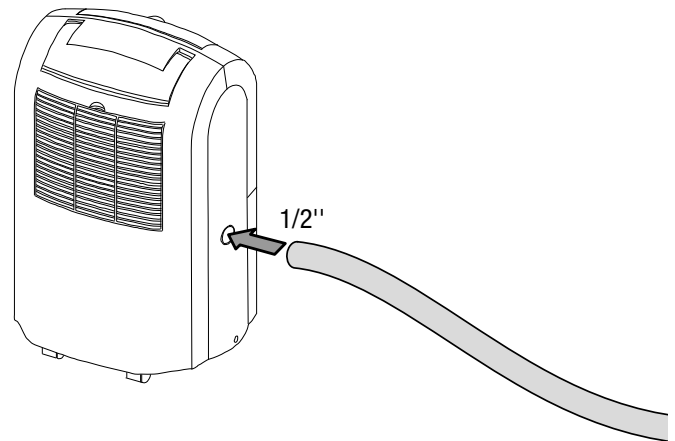

4. Check whether the hose is properly positioned on the connection. If necessary, adjust the position through the condensation tank opening.

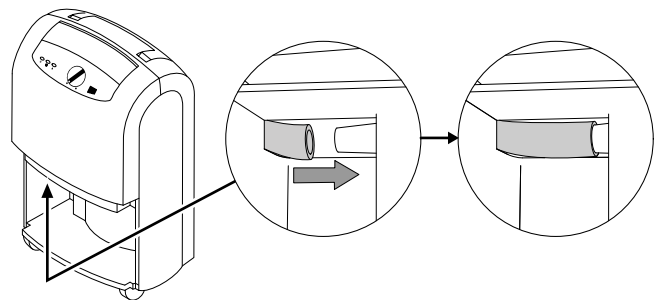

5. Put the condensation tank back in.

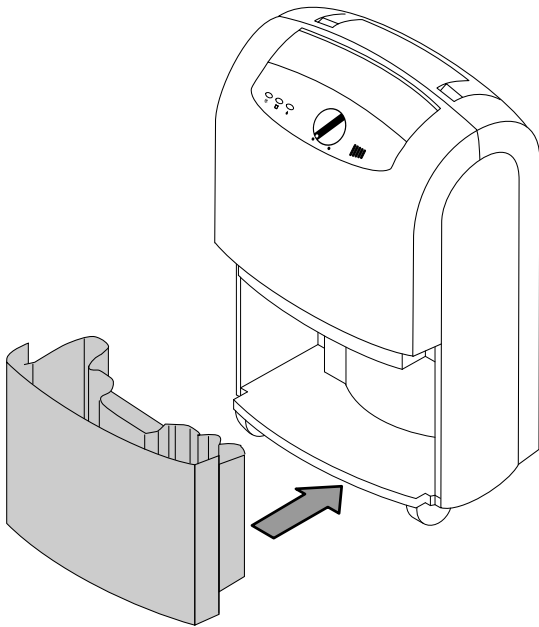

6. Guide the other hose end to a suitable drain or sufficiently dimensioned collection container. Please note that the hose must not be kinked.

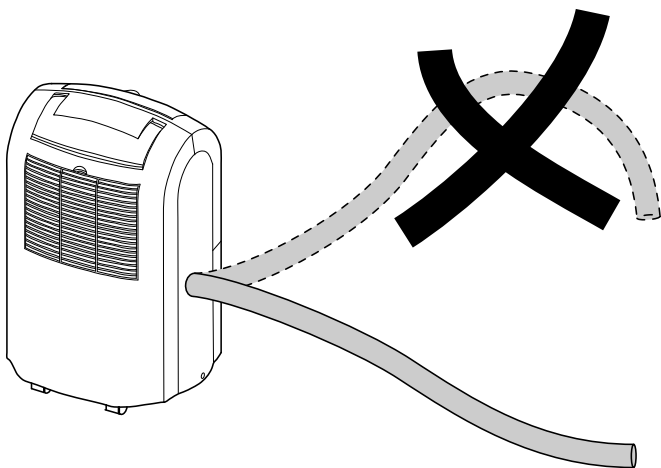

Remove the hose if you want to collect the condensate in the condensation tank again. Allow the hose to dry prior to storage. The hose can be connected in any operating mode for continuous operation.

Automatic defrost

At low ambient temperatures, ice may form at the evaporator during dehumidification. The device then carries out an automatic defrost by means of the hot gas feed. Here, a hot cooling agent is led into the iced evaporator for its surfaces to defrost.

The hot gas automatic defrost system integrated in the device automatically switches on the defrost cycle at regular intervals. The *automatic defrost* LED (8) is illuminated throughout the defrost process.

The duration of the defrost process can vary. Do not switch off the device during automatic defrost. Do not remove the mains plug from the mains socket.

Drying laundry

In addition, the device may also be used as a kind of clothes dryer to dry wet laundry in living or working spaces.

When positioning the device or a clothes horse, please observe the minimum distances specified in the technical data.

For drying laundry the following values should be selected:

- cupboard dry = 46 % relative humidity
- iron dry = 58 % relative humidity
- slightly dried = 65 % relative humidity

If necessary, use a measuring device to determine the humidity level.

Shutdown



Warning of electrical voltage

Do not touch the mains plug with wet or damp hands.

- Switch off the device.
- Hold onto the mains plug while pulling the power cable out of the mains socket.
- If necessary, remove the condensation drain hose and any residual fluid from it.
- Empty the condensation tank, if need be.
- Clean the device according to the Maintenance chapter.
- Store the device according to the Storage chapter.

Errors and faults

The device has been checked for proper functioning several times during production. If malfunctions occur nonetheless, check the device according to the following list.

The device does not start:

- Check the power connection.
- Check the power cable and mains plug for damage.
- Check the on-site fusing.
- Check the condensation tank for correct seating.
- Check the room temperature. Observe the device's permissible operating range according to the technical data.
- Wait for 10 minutes before restarting the device. If the device is not starting, have the electricians checked by a specialist company or by Trotec.

The device is running, but there is no formation of condensate:

- Check the float in the condensation tank for dirt. If necessary, clean the condensation tank. The float must be able to move freely.
- Check the room temperature. Observe the device's permissible operating range according to the technical data.
- Ensure that the relative room humidity complies with the technical data.
- Check the air filter for dirt. If necessary, clean or replace the air filter.
- From the outside, check the condenser for dirt (see chapter Maintenance). If the condenser is dirty, have it cleaned by a specialist company or by Trotec.
- The device might carry out an automatic defrost. During automatic defrost, the device does not dehumidify.

The device is loud or vibrates:

- Check whether the device is set up in a stable and upright position.

Condensate is leaking:

- Check the device for leaks.

The compressor does not start:

- Check the room temperature. Observe the device's permissible operating range according to the technical data.
- Ensure that the relative room humidity complies with the technical data.
- Check whether the overheating protection of the compressor has tripped. Disconnect the device from the mains and let it cool down for approx. 10 minutes before reconnecting it.
- The device might carry out an automatic defrost. During automatic defrost, the device does not dehumidify.

The device gets very warm, is loud or loses power:

- Check the air inlets and air filters for dirt. Remove external dirt.
- From the outside, check the device for dirt (see chapter Maintenance). If the inside of the device is dirty, have it cleaned by a specialist company for cooling and air-conditioning or by Trotec.

Note

Wait for at least 3 minutes after maintenance and repair work. Only then switch the device back on.

Your device still does not operate correctly after these checks?

Please contact the customer service. If necessary, bring the device to a specialist company for cooling and air-conditioning or to Trotec for repair.

Maintenance

Maintenance intervals

Maintenance and care interval	before every start-up	as needed	at least every 2 weeks	at least every 4 weeks	at least every 6 months	at least annually
Check the air inlets and outlets for dirt and foreign objects and clean if necessary	X			X		
Clean the exterior		X				X
Visually check the inside of the device for dirt		X				X
Check the air filter for dirt and foreign objects and clean or replace if necessary	X		X			
Replace the air filter					X	
Check for damage	X					
Check the attachment screws		X				X
Test run						X
Empty the condensation tank and/or drain hose		X				

Maintenance and care log

Device type:

Device number:

Maintenance and care interval	1	2	3	4	5	6	7	8	9	10	11	12	13	14	15	16
Check air inlets and outlets for dirt and foreign objects and clean if necessary																
Clean the exterior																
Visually check the inside of the device for dirt																
Check the air filter for dirt and foreign objects and clean or replace if necessary																
Replace the air filter																
Check for damage																
Check the attachment screws																
Test run																
Empty the condensation tank and/or drain hose																
Comments																

1. Date: Signature:	2. Date: Signature:	3. Date: Signature:	4. Date: Signature:
5. Date: Signature:	6. Date: Signature:	7. Date: Signature:	8. Date: Signature:
9. Date: Signature:	10. Date: Signature:	11. Date: Signature:	12. Date: Signature:
13. Date: Signature:	14. Date: Signature:	15. Date: Signature:	16. Date: Signature:

Activities required before starting maintenance



Warning of electrical voltage

Do not touch the mains plug with wet or damp hands.

- Switch the device off.
- Hold onto the mains plug while pulling the power cable out of the mains socket.



Warning of electrical voltage

Tasks which require the housing to be opened must only be carried out by authorised specialist companies or by Trotec.

Refrigerant circuit

- The entire refrigerant circuit is a maintenance-free, hermetically sealed system and may only be maintained or repaired by specialist companies for cooling and air-conditioning or by Trotec.

Cleaning the housing

Clean the housing with a soft, damp and lint-free cloth. Ensure that no moisture enters the housing. Protect electrical components from moisture. Do not use any aggressive cleaning agents such as cleaning sprays, solvents, alcohol-based or abrasive cleaners to dampen the cloth.

Visual inspection of the inside of the device for dirt

1. Remove the air filter.
2. Use a torch to illuminate the openings of the device.
3. Check the inside of the device for dirt.
4. If you see a thick layer of dust, have the inside of the device cleaned by a specialist company for cooling and air-conditioning or by Trotec.
5. Put the air filter back in.

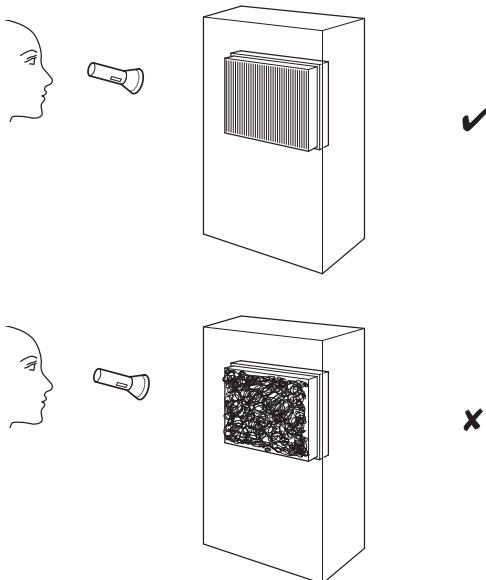

Cleaning the air filter

Note

Ensure that the air filter is not worn or damaged. The corners and edges of the air filter must not be deformed or rounded. Before reinserting the air filter, make sure that it is undamaged and dry!

The air filter has to be cleaned as soon as it is dirty. This is brought to light e.g. by a reduced capacity (see chapter Errors and faults).

1. Open the flap at the air inlet.

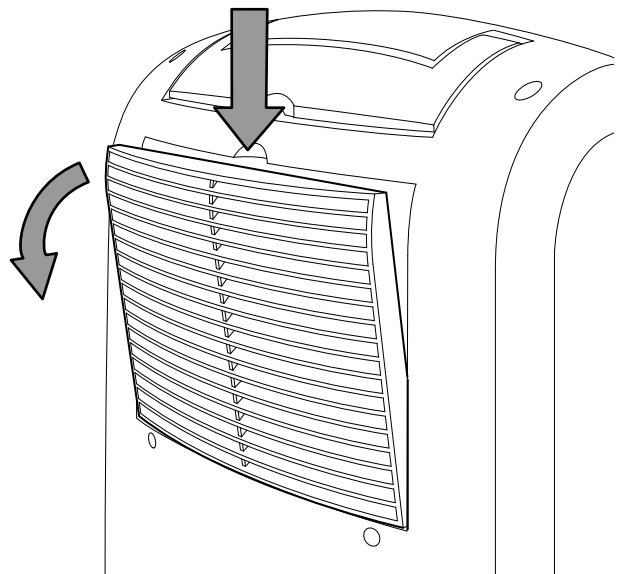

2. Remove the air filter.

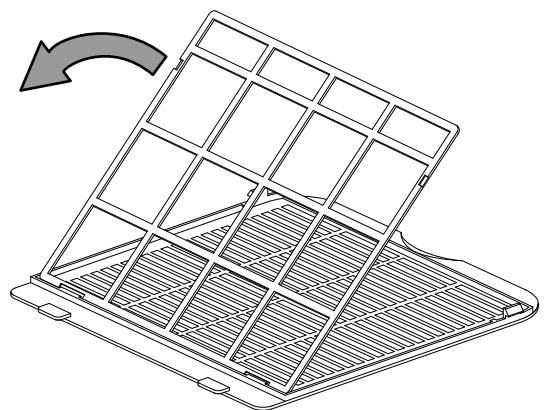

3. Clean the filter using a slightly damp, soft, lint-free cloth. If the filter is heavily contaminated, clean it with warm water mixed with a neutral cleaning agent.

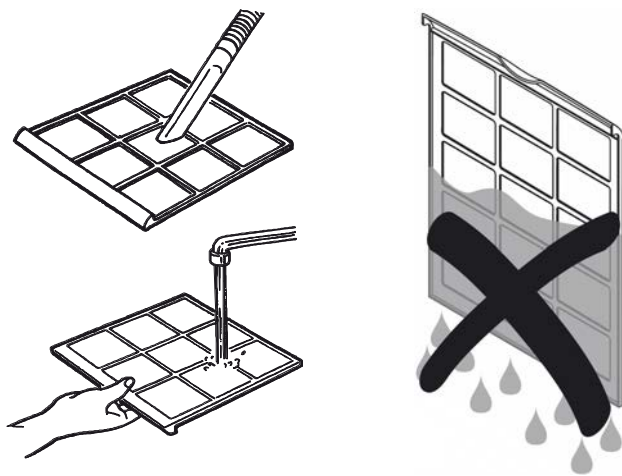

6. Reinsert the flap into the device.

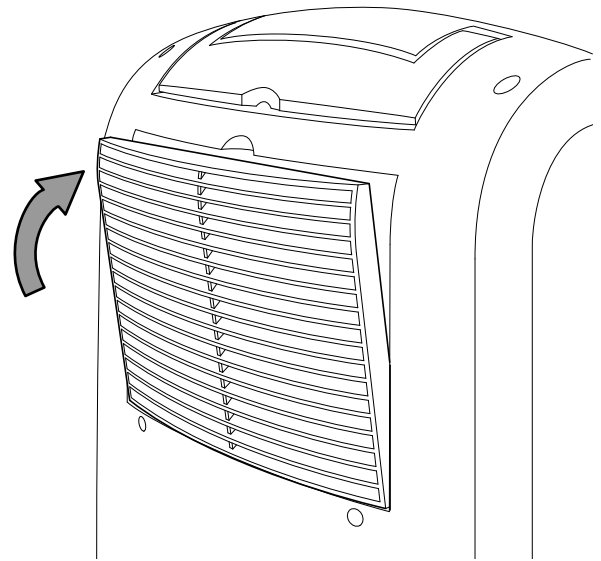

4. Allow the filter to dry completely. Do not insert a wet filter into the device!
5. Put the air filter back in.

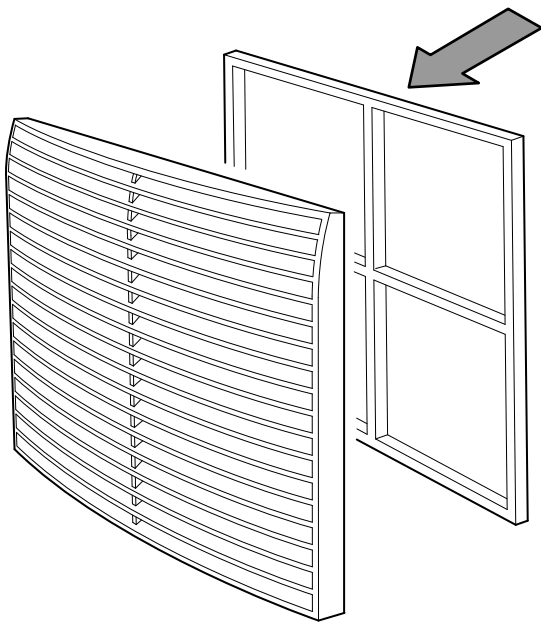

Emptying the condensation tank

If the condensation tank is full or not installed correctly, the *TANK FULL* LED (9) will be illuminated. The compressor and fan will switch off.

1. Take the condensation tank out of the device.

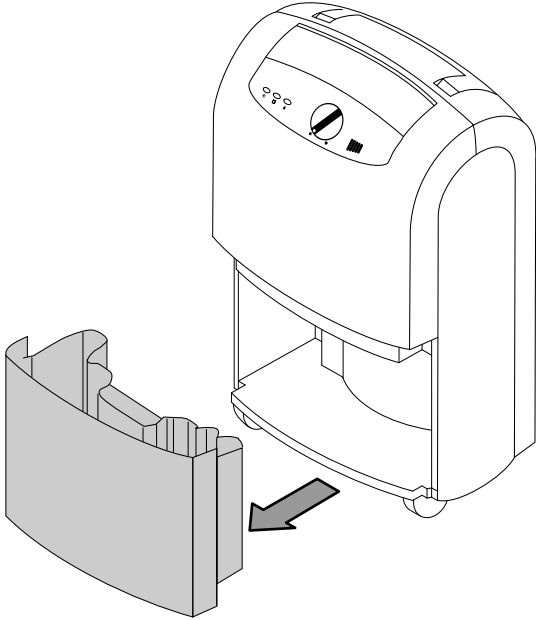

2. Empty the condensation tank into a drain or sink.

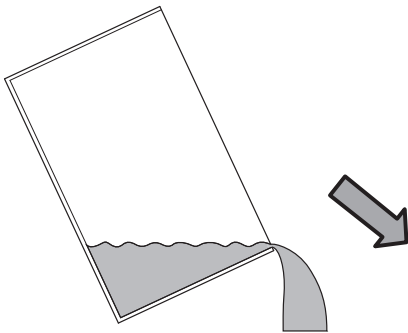

3. Rinse the condensation tank with clear water. Regularly clean the condensation tank using a mild cleaning agent (no detergent!).

4. Refit the condensation tank into the device. Make sure not to damage the float when inserting or removing the condensation tank. In doing so, make sure that the float is positioned correctly. In doing so, make sure that the condensation tank is inserted correctly, since otherwise the device cannot be switched back on.

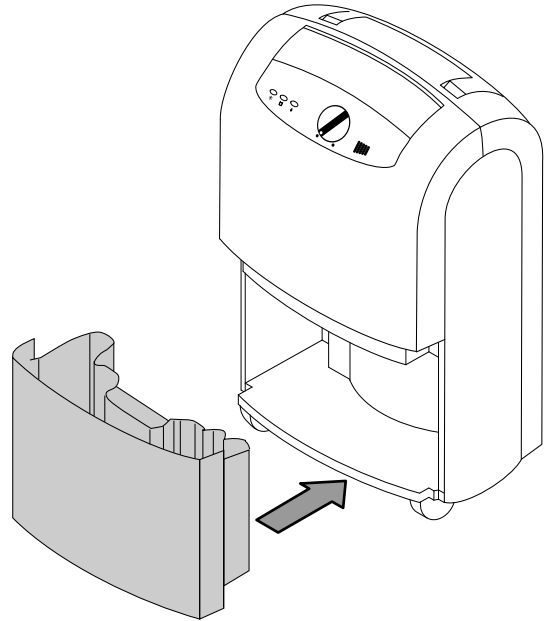

Activities required after maintenance

If you want to continue using the device:

- Leave the device to rest for 12 to 24 hours, so the refrigerant can accumulate within the compressor. Wait 12 to 24 hours before switching the device back on! Acting contrary might lead to compressor damage and a malfunctioning device. If so, any warranty claims will be voided.
- Reconnect the device to the mains.

If you do not intend to use the device for a considerable time:

- Store the device according to the Storage chapter.

Technical annex

Technical data

Parameter	Value
Model	TTK 100 S
Max. dehumidification performance	30 l / 24 h
Air volume	200 m ³ /h
Operating range (temperature)	5 °C to 32 °C
Operating range (relative humidity)	30 % to 80 % RH
Mains connection	1/N/PE ~ 220 – 240 V / 50 Hz
Max. power input	0.6 kW
Nominal current	2.6 A
Recommended fusing	10 A
Refrigerant	R-410A
Amount of refrigerant	210 g
GWP factor	2088
CO ₂ equivalent	0.44 t
Water tank	4.3 l
Sound pressure level	46 dB(A)
Dimensions (length x width x height)	290 x 390 x 612 mm
Minimum distance to walls and other objects	A: top: 50 cm B: rear: 50 cm C: side: 50 cm D: front: 50 cm
Weight	15 kg

Disposal



The icon with the crossed-out waste bin on waste electrical or electronic equipment stipulates that this equipment must not be disposed of with the household waste at the end of its life. You will find collection points for free return of waste electrical and electronic equipment in your vicinity. The addresses can be obtained from your municipality or local administration. For further return options provided by us please refer to our website www.trotec24.com.

The separate collection of waste electrical and electronic equipment aims to enable the re-use, recycling and other forms of recovery of waste equipment as well as to prevent negative effects for the environment and human health caused by the disposal of hazardous substances potentially contained in the equipment.

The device is operated with fluorinated greenhouse gas which can be dangerous for the environment and contribute to global warming when emitted to the atmosphere.

Further information is provided on the nameplate.

Dispose of the refrigerant appropriately and according to the national regulations.

Trotec GmbH

Grebener Str. 7
D-52525 Heinsberg

☎ +49 2452 962-400

☎ +49 2452 962-200

✉ info@trotec.com

www.trotec.com